



MAGIS COMBO

Split single-phase
reversible air-water
hybrid heat pumps



MAIN INDEX

1	MAGIS COMBO 5 - 8 - 10 (SINGLE-PHASE), INSTANT AND PLUS FEATURES.....	5
2	AUDAX PRO DIMENSIONS AND CONNECTIONS (CONDENSING UNIT)	6
3	MAGIS COMBO MAIN DIMENSIONS	7
4	MAGIS COMBO PLUS MAIN DIMENSIONS.....	8
5	SINGLE AUDAX PRO MINIMUM INSTALLATION DISTANCES.....	9
6	DRAIN HOLES AND CONDENSATE DRAIN.....	11
7	COOLING CIRCUIT FUNCTIONING LIMITS	12
8	MAGIS COMBO MAIN COMPONENTS	13
9	MAGIS COMBO PLUS MAIN COMPONENTS.....	14
10	GRAPH OF HEAT PUMP CIRCULATOR FLOW RATE/HEAD	15
11	GRAPH OF HEAT GENERATOR PUMP FLOW RATE/HEAD	16
12	MAGIS COMBO HYDRAULIC DIAGRAM	17
13	MAGIS COMBO PLUS HYDRAULIC DIAGRAM.....	18
14	AUDAX PRO (EXTERNAL CONDENSING UNIT) HYDRAULIC DIAGRAM	19
15	MAGIS COMBO ELECTRONIC MANAGEMENT FUNCTIONS.....	20
16	ELECTRIC CONNECTION CABLES FEATURES	30
17	OUTDOOR UNIT TERMINAL BLOCK ELECTRICAL CONNECTIONS.....	31
18	MAGIS COMBO TERMINAL BLOCK ELECTRICAL CONNECTIONS	32
19	MAGIS COMBO / MAGIS COMBO PLUS P.C.B.	33
20	INSTALLING THE CHILLER LINES	37
21	MAGIS COMBO / MAGIS COMBO PLUS (HEAT PUMP) TECHNICAL DATA.....	39
22	MAGIS COMBO / MAGIS COMBO PLUS (HEAT GENERATOR) TECHNICAL DATA	40
23	MAGIS COMBO / MAGIS COMBO PLUS (HEAT GENERATOR) COMBUSTION FEATURES.....	41
24	MAGIS COMBO 5 / MAGIS COMBO 5 PLUS PRODUCT FICHE (REGULATION 811/2013).....	42
25	"POWERS" "COP" AND "EER" MAGIS COMBO 5 / MAGIS COMBO 5 PLUS	43
26	MAGIS COMBO 8 / MAGIS COMBO 8 PLUS PRODUCT FICHE (REGULATION 811/2013).....	44
27	"POWERS" "COP" AND "EER" MAGIS COMBO 8 / MAGIS COMBO 8 PLUS	45
28	MAGIS COMBO 10 / MAGIS COMBO 10 PLUS PRODUCT FICHE (REGULATION 811/2013).....	46
29	"POWERS" "COP" AND "EER" MAGIS COMBO 10 / MAGIS COMBO 10 PLUS	47
30	KIT 2 ZONES FOR COUPLING MAGIS COMBO (CODE 3.026301)	48
31	SYSTEM MANAGER.....	54
32	REMOTE CONTROL OF ZONE (WITH SYSTEM MANAGER)	55
33	TEMPERATURE/HUMIDITY SENSOR (WITH SYSTEM MANAGER)	55
34	EXPANSION BOARD FOR ZONE MANAGEMENT (WITH SYSTEM MANAGER)	55
35	DISTRIBUTION KIT TO THE SYSTEM (WITH SYSTEM MANAGER).....	56
36	DEHUMIDIFIER.....	60
37	OPTIONAL FOR DIRECT COUPLING TO MAGIS COMBO / COMBO PLUS	64
38	OPTIONAL IN THE PRESENCE OF SYSTEM MANAGER.....	65
39	MAIN INERTIAL STORAGE TANK TECHNICAL FEATURES.....	66
40	MAGIS COMBO OPERATING PRINCIPLES.....	68
41	MAGIS COMBO PLUS OPERATING PRINCIPLES	73
42	OPERATING PRINCIPLES.....	79
43	INTRODUCTION WITH COMMENTARY TO THE DIAGRAMS: MAIN APPLICATIONS.....	81
44	HYDRAULIC DIAGRAM: MAGIS COMBO (INSTANT) + 2 ZONE KIT (1 DIRECT AND 1 MIXED) + THERMAL SOLAR SYSTEMS.....	82
45	HYDRAULIC DIAGRAM: MAGIS COMBO PLUS + 2 ZONE KIT (1 DIRECT AND 1 MIXED) + PHOTOVOLTAIC.....	84

MAGIS COMBO



Range of "split" inverter driven reversible air/water hybrid heat pumps, consisting of an outdoor condensing unit and of an indoor unit (with hydronic exchange unit with chiller unit and condensation unit); a single code identifies the complete system (indoor unit + outdoor condensing unit). They are available 3 combi versions (MAGIS COMBO 5, MAGIS COMBO 8 and MAGIS COMBO 10) and 3 heating (cooling) only versions (MAGIS COMBO 5 PLUS, MAGIS COMBO 8 PLUS and MAGIS COMBO 10 PLUS), all with single-phase supply voltage. The water circuit is potentially protected against freeze being set up home installation (in this case there is no need to add glicole); on this point of view, the system is, therefore, particularly suitable for cold climate areas.

Refrigerant connections between the outdoor condensing unit and the indoor unit have to be provided during the installation phase.

MAGIS COMBO is the ideal solution for the most comfortable room climate conditions both when working in central heating mode (maximum flow temperature 80°C) and in cooling mode. Furthermore it possible to choose between instantaneous DHW production version (thank to the built-in plate heat exchanger), and the one to be coupled with a separate storage tank unit (PLUS model).

The advanced, mutual integration between the heat generators (heat pump and indoor hydronic unit) brings important advantages both on the installation easiness and the overall dimensions reduction, especially if compared to custom solutions.

The electronic operated system control is based on an activation logic which allows to exploit the most convenient energy source (heat pump / condensation unit) in every moment and with any outdoor weather condition; thanks to the simplified wiring method, makes the installation of System Manager controller not necessary in every condition (even if it is still available as optional solution in order to manage particular installation layouts, such as systems spreading over more than two zones).

The MAGIS COMBO IPX4D-protected indoor unit is certified as weather-proof both in outdoor installation conditions and in partially sheltered areas.

MAGIS COMBO is compliant both to ErP Directive (2009/125/EC) requirements and to EL Directive (2010/30/EC) ones. A wide range of optional kits fit to satisfy many possible plant options is available yet.

If compared to a single condensing boiler, MAGIS COMBO allows a considerable energy saving; in the meantime, it need very restrained space. For this reason, it is ideal not just for new housing solutions (especially the PLUS version, which also uses the heat pump for the production of DHW, making the compliance to standards requirements easier), but also when replacement of obsolete boilers becomes the good occasion to increase the usage of renewable energy (in this case, the instant version is particularly suitable for the purpose).

MAGIS COMBO is ideal for achieving high energy classification of new residential buildings.



MAGIS COMBO

1 MAGIS COMBO 5 - 8 - 10 (SINGLE-PHASE), INSTANT AND PLUS FEATURES

"Split" inverter-driven reversible air/water hybrid heat pumps, consisting of an outdoor condensing unit and a wall-hung indoor unit; a unique kit code identifies the complete system comprising the following main components:

- **Outdoor condensing unit** (called AUDAX PRO) which mainly includes inverter-driven, rotary-type compressor, electronic controls, throttle valve, 4-way diverting valve for cycle inversion, single-fan air-cooled, gilled-tube heat-exchanger. Preloaded refrigerant circuit supplied as standard (R410A refrigerant gas). The device is equipped as standard with shut-off valves for the R410A circuit filling;
- **Wall-hung indoor unit**, which includes:
 - The whole hydraulic equipment dotation needed for connecting the unit to the heating/cooling system, as well as the electronic control devices and probes for the connectivity with the outdoor condensing unit. In particular, they are built-in the indoor unit: 48-plates R410A/water heat exchanger, 10-litre system expansion vessel, flow-meter, transformer for management of the internal communication board with outdoor condensing unit, and all the related electronic devices;
 - Condensing unit equipped with integrative full-premixed combustion system consisting of steel alloy multigas cylindrical burner, complete with ignition electrode, ionisation control electrode and double shutter pneumatic gas valve, gas/water primary heat exchanger with composite casing and stainless steel internal coil, stainless steel combustion chamber thermally insulated with inner ceramic panels, electronic-controlled variable-speed fan for the forced draught, prearrangements for the condensate drainage including siphon and flexible drain hose;
 - Water/water 14-plates stainless steel secondary heat exchanger for the D.H.W. production water, D.H.W. flow switch for withdrawal activation (MAGIS COMBO instant version);
 - Hydraulic unit consisting of 3-way electric valve, low consumption 7 mH₂O (4°C) head circulation pump (associated with the condensation generator operation), low consumption 7.5 mH₂O (4°C) head circulation pump (associated with cooling circuit operation), absolute pressure switch for the primary circuit control, 3-bar primary circuit safety relief valve, system drain fitting and cock for system filling. Moreover, MAGIS COMBO, in the PLUS version is equipped with an additional 3-way electric valve to manage the D.H.W. production by using heat pump;
 - Control panel equipped with central heating circuit pressure gauge, multi-purpose display and 7-digit keyboard for setting and adjusting the generator operating parameters: central heating/cooling temperature adjustment buttons, DHW temperature adjustment buttons, summer/winter mode button, reset button, menu button;
 - Self-diagnosis system with digital display showing the system operating conditions or error codes;
 - Ignition delay device in C.H. mode, anti-freeze protection system (up to -5°C), pump anti-block device function, three-way valve anti-block device function, chimney sweep function, automatic vent function, screed heating function;

- IPX4D electric insulation degree;
- Possibility of coupling to Ø 50 mm, Ø 60 mm and Ø 80 mm (for condensation units) ducting systems
- C.H. delivery temperature value adjustable by setting dedicated menu;
- Hydraulically the indoor unit is set-up for connection to 1 heating/cooling zone and for connection to the DHW storage tank (PLUS version) or to the D.H.W. circuit (combi version); R410A connections to the condensing unit are prearranged as standard;
- Hydraulic circuit freeze-protection given by the presence of the gas/water heat exchanger pre arranged for indoor installation (very important feature in cold climates);
- MAGIS COMBO electronic control system is prearranged for managing up 2 zones (one direct and one of the mixed type), both when working in heating and cooling mode; in this particular case, MAGIS COMBO is prearranged for working with one or two CAR^{v2} (or CHRONO 7) in order to control the room temperature of the 2 zones. Two humidistats or two temperature and humidity sensors can be connected to control humidity;
- Possible setting of 2 different climatic curves (for the 2 zones);
- 2 relay board optional kit available for the operation control of up 2 dehumidifiers (one for each system zone);
- Anti-legionella function programmable by setting MAGIS COMBO electronic card via CAR^{v2};
- PV-activated forced operation function (dedicated gateway for photovoltaic system inverter connection);
- Connectable to the System Manager (optional) in order to manage systems with more than 2 zones.

Supplied with sample points for combustion analysis, bottom part protection casing, connection group, intercepting valve with filter on system return, intercepting valve on the system delivery, gas interception valve and DCW valve.

Category II appliance, _{2H3B/P} functions with a natural gas, L.P.G. and propane air.

It is available in the instant models:

- | | |
|-----------------------------|----------------------|
| • MAGIS COMBO 5 | code 3.027234 |
| • MAGIS COMBO 5 GPL | code 3.027246 |
| • MAGIS COMBO 8 | code 3.027235 |
| • MAGIS COMBO 8 GPL | code 3.027247 |
| • MAGIS COMBO 10 | code 3.027236 |
| • MAGIS COMBO 10 GPL | code 3.027248 |

Or it is available in the PLUS models:

- | | |
|----------------------------------|----------------------|
| • MAGIS COMBO 5 PLUS | code 3.027237 |
| • MAGIS COMBO 5 PLUS GPL | code 3.027249 |
| • MAGIS COMBO 8 PLUS | code 3.027238 |
| • MAGIS COMBO 8 PLUS GPL | code 3.027250 |
| • MAGIS COMBO 10 PLUS | code 3.027239 |
| • MAGIS COMBO 10 PLUS GPL | code 3.027251 |

2 AUDAX PRO DIMENSIONS AND CONNECTIONS (CONDENSING UNIT)

AUDAX PRO 5

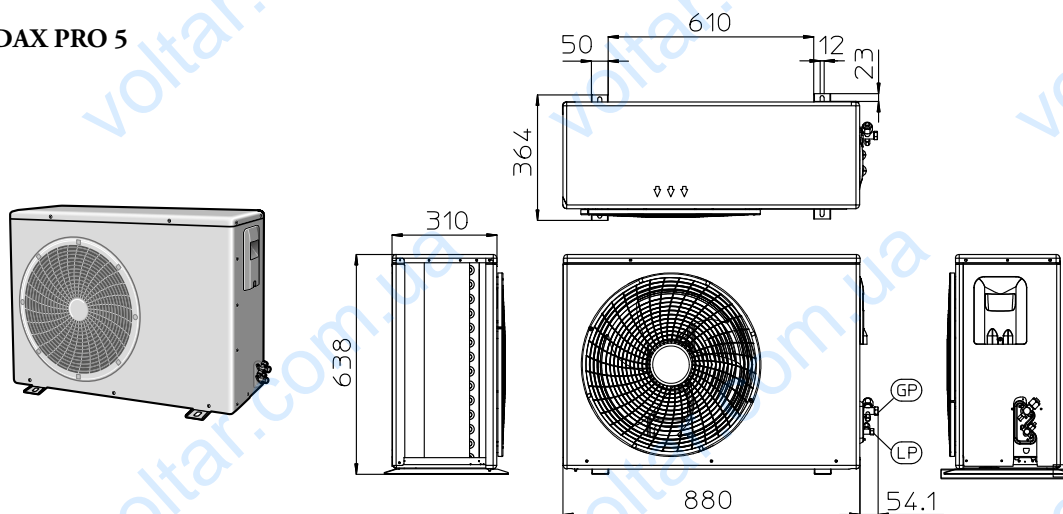

Height = 638 mm	Width = 880 mm	Depth = 364 mm	Condensate drain = Ø 20 mm
------------------------	-----------------------	-----------------------	-----------------------------------

R410A

Model

LP (Cooling liquid)

GP (Gaseous liquid)

AUDAX PRO 5

1/4" (6.35 mm)

5/8" (15.88 mm)

AUDAX PRO 8 / 10

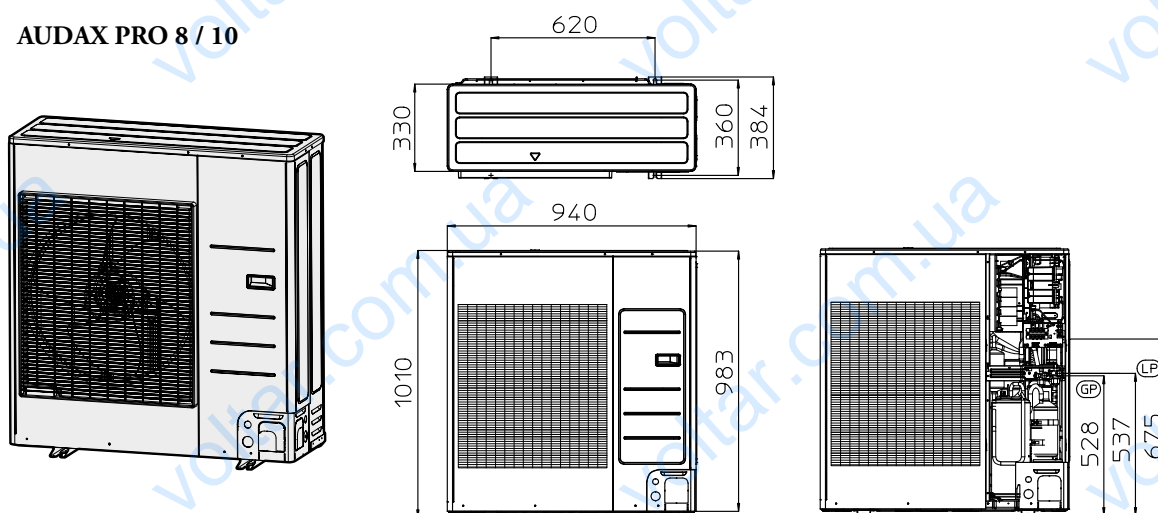

Height = 1010 mm	Width = 940 mm	Depth = 384 mm	Condensate drain = Ø 20 mm
-------------------------	-----------------------	-----------------------	-----------------------------------

R410A

Model

LP (Cooling liquid)

GP (Gaseous liquid)

AUDAX PRO 8/10

3/8" (9.52 mm)

5/8" (15.88 mm)

MAGIS COMBO

3 MAGIS COMBO MAIN DIMENSIONS

Model	Height mm	Width mm	Depth mm	Ø intake/exhaust mm
MAGIS COMBO	787	440	400	100/60 - 125/80 - 80/80

3.1 MAGIS COMBO CONNECTIONS

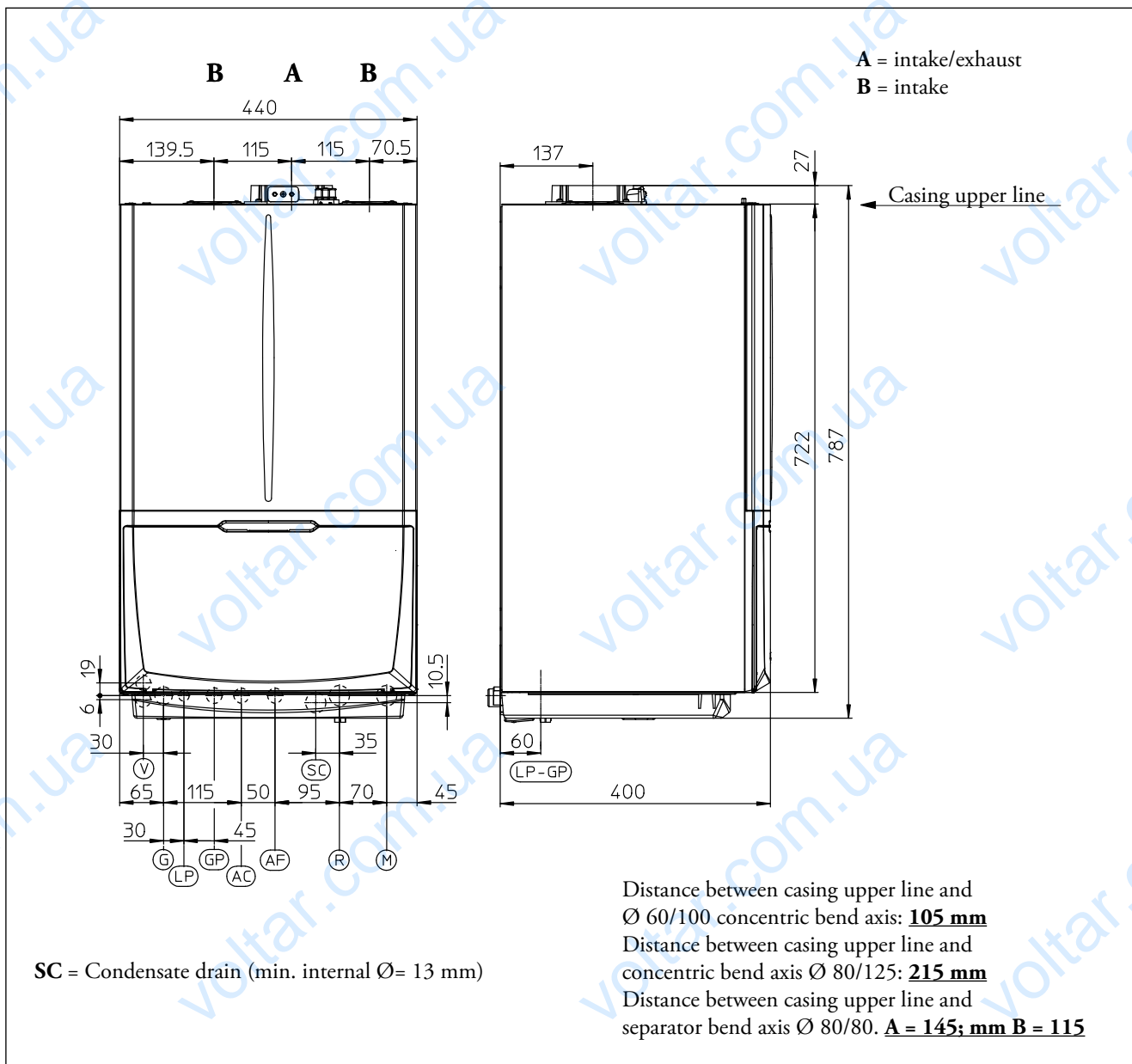

MAGIS COMBO							
Flow System M 3/4"	Return system R 3/4"	Inlet Cold AF 1/2"	Hot Outlet AC 1/2"	R410A GP 5/8" (15.88 mm)	R410A LP 3/8" (9.52 mm)	Gas G 3/4"	Expansion vessel Litres 10 (real 8.3)

MAGIS COMBO

4 MAGIS COMBO PLUS MAIN DIMENSIONS

Model	Height mm	Width mm	Depth mm	Ø intake/exhaust mm
MAGIS COMBO PLUS	787	440	400	100/60 - 125/80 - 80/80

4.1 MAGIS COMBO PLUS CONNECTIONS

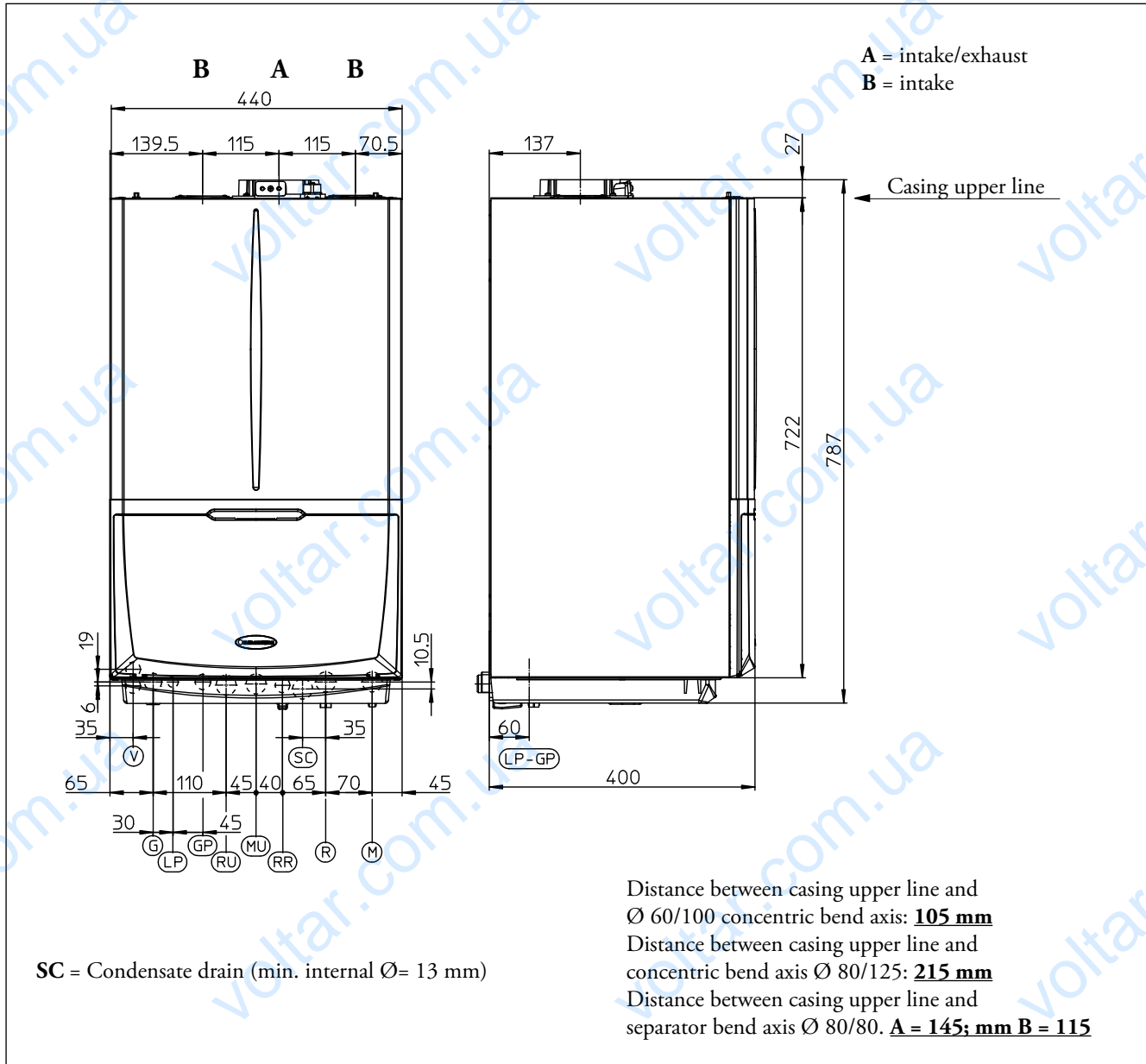

MAGIS COMBO PLUS

Flow System	Return system	System Filling RR	Storage tank Flow	Storage tank return	R410A GP	R410A LP	Gas G	Expansion vessel Litres
M 3/4"	R 3/4"	1/2"	MU 3/4"	RU 3/4"	5/8" (15.88 mm)	3/8" (9.52 mm)	3/4"	10 (real 8.3)

MAGIS COMBO

5

SINGLE AUDAX PRO MINIMUM INSTALLATION DISTANCES

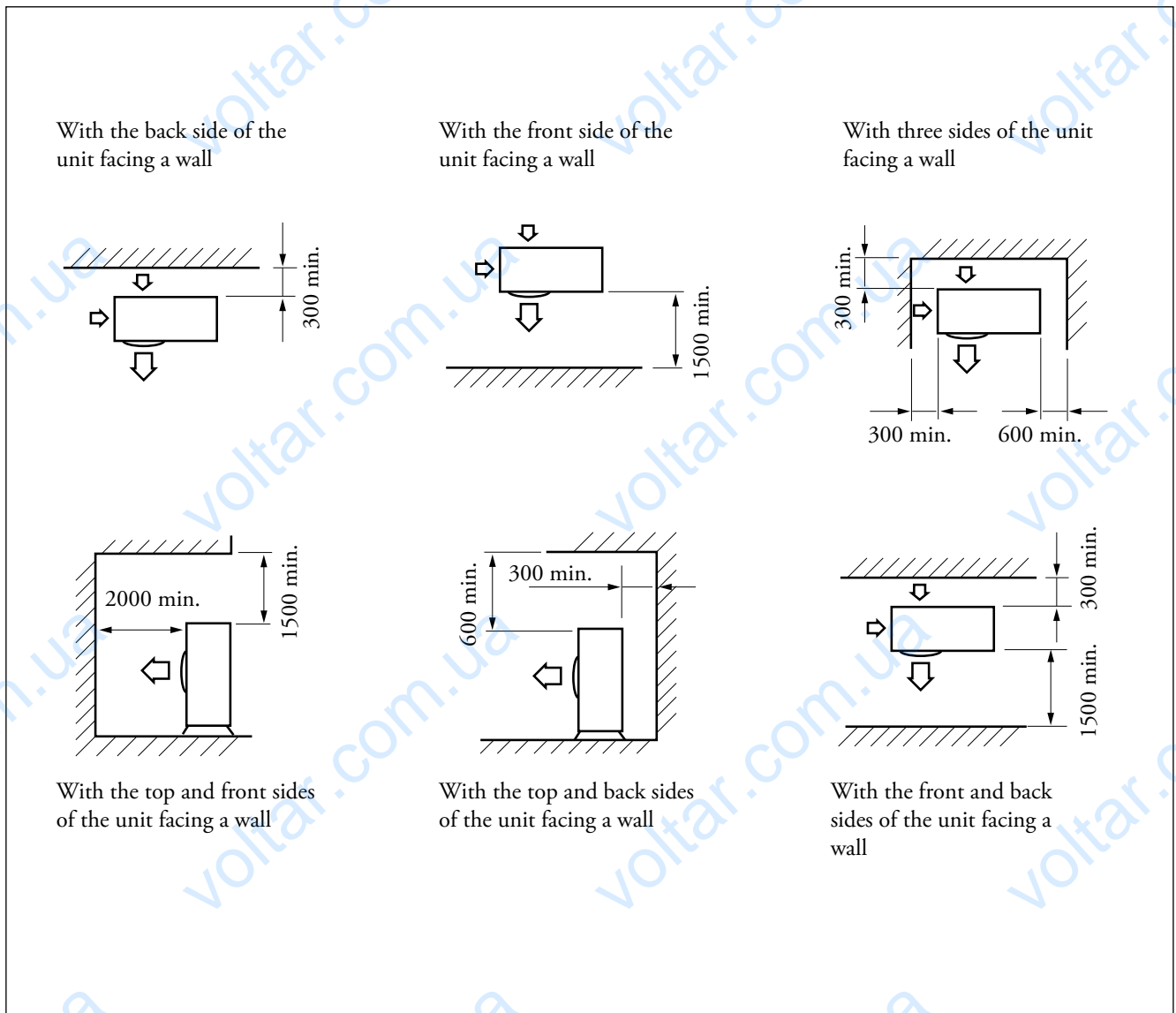

Place of installation:

The place of installation is very important and must be established by the system's designer or by a specifically qualified person, and must consider the technical requirements, standards and laws in force.

- The condensing unit must be installed outside the building only; the indoor unit must be installed inside the building or outdoors in a partially protected place;
- It is recommended to avoid:
 - positioning in basement windows;
 - obstacles or barriers that cause recirculation of exhaust air;
 - places with aggressive atmospheres;
 - limited spaces or anyhow in places where sound levels from the appliance can be enhanced through reverberations or resonance;
 - positioning in corners where there is an accumulation of dust, leaves and anything else that can reduce the appliance's efficiency due to blocked passageways;

- prevent exhaust air from the device from coming into the rooms through doors or windows, thus disturbing people;
- The appliances must:
 - be placed on a level surface that is able to withstand its weight;
 - be placed on a slab that is hard enough and which does not transfer any vibrations to the underlying or adjacent rooms;
 - use the vibration-dampening supports supplied with the machine.
- If the unit is installed in zones subject to heavy snow, it will be necessary to raise the machine by at least the height of the strongest expected snowfall or, alternatively, use wall-support brackets (not supplied).

5.1 AUDAX PRO MINIMUM INSTALLATION DISTANCES (SEVERAL APPLIANCES)

The front side of the unit facing a wall

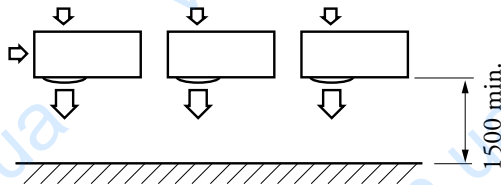

With three sides of the units facing a wall

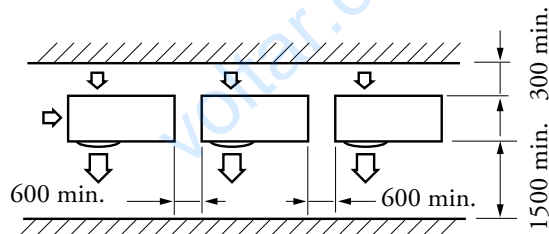
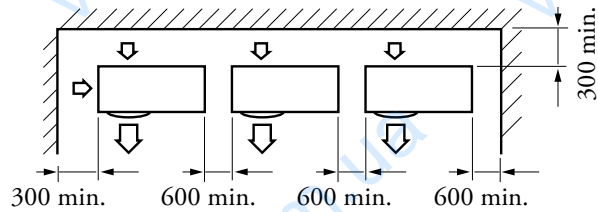

With the front and back sides of the units facing a wall

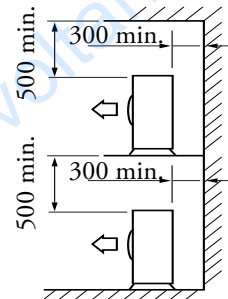

With the top and front sides of the units facing a wall

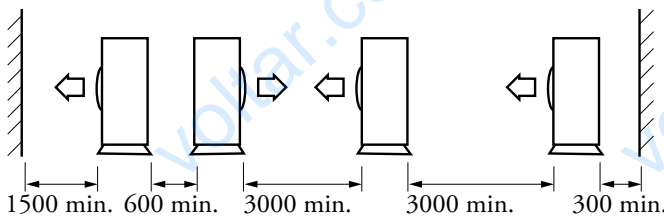

With the units facing each other and with the front and back sides of the end units facing a wall

- the unit must be installed in a position protected from snow falling from above. If this is not possible, you must at least prevent the snow from clogging the air/coolant exchanger (even by constructing a small protective roof for the unit, if necessary);
- the effects of the wind can be minimised by installing the unit with the intake side facing a wall;
- the unit must not be installed with the intake side against the wind;
- the effects of the wind can be further minimised by installed a deflector plate facing the unit air flow side (not supplied).

N.B.: The spaces shown must be left free to allow air to circulate and to ensure accessibility for repairs or maintenance on every side of the units. In fact, it must be possible to disassemble all the unit components under the utmost safety conditions (both for objects and for people).

MAGIS COMBO

6

DRAIN HOLES AND CONDENSATE DRAIN

If the produced condensate is drained through the drain pipe, connect the standard supplied drain fitting (1) in one of the drainage holes on the bottom of the appliance and close the other holes with drain plugs (this refers to AUDAX PRO 8 and 10) and use the drain pipe (16 mm internal diameter) commercially available so that it conveys the water to the desired location. In the event of installation in very cold zones or zones subject to heavy snow where the condensate drain pipe can freeze, take the necessary precautions to keep the drainage holes or the condensate drain pipe free.

N.B.: If the water produced by the unit is not properly drained, the performance of the entire system will suffer a negative impact and the system itself could be damaged.

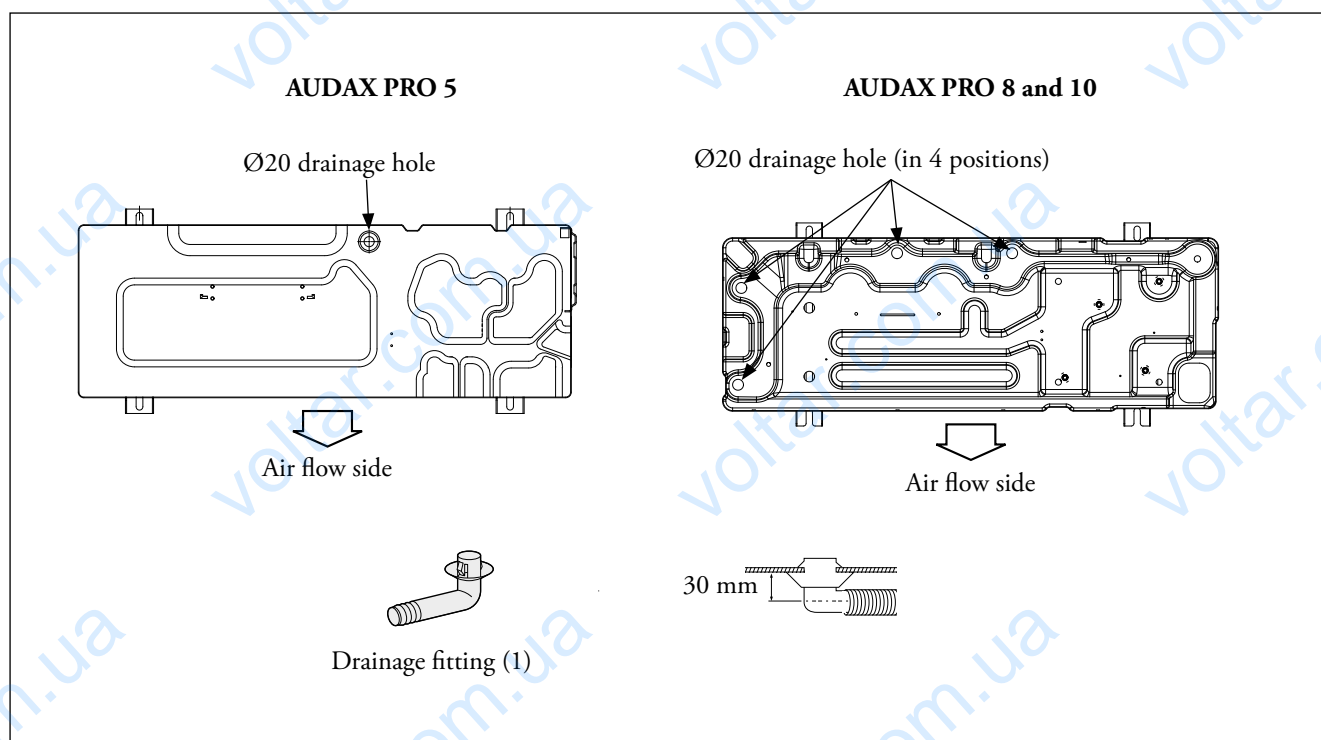

7 COOLING CIRCUIT FUNCTIONING LIMITS

Central heating

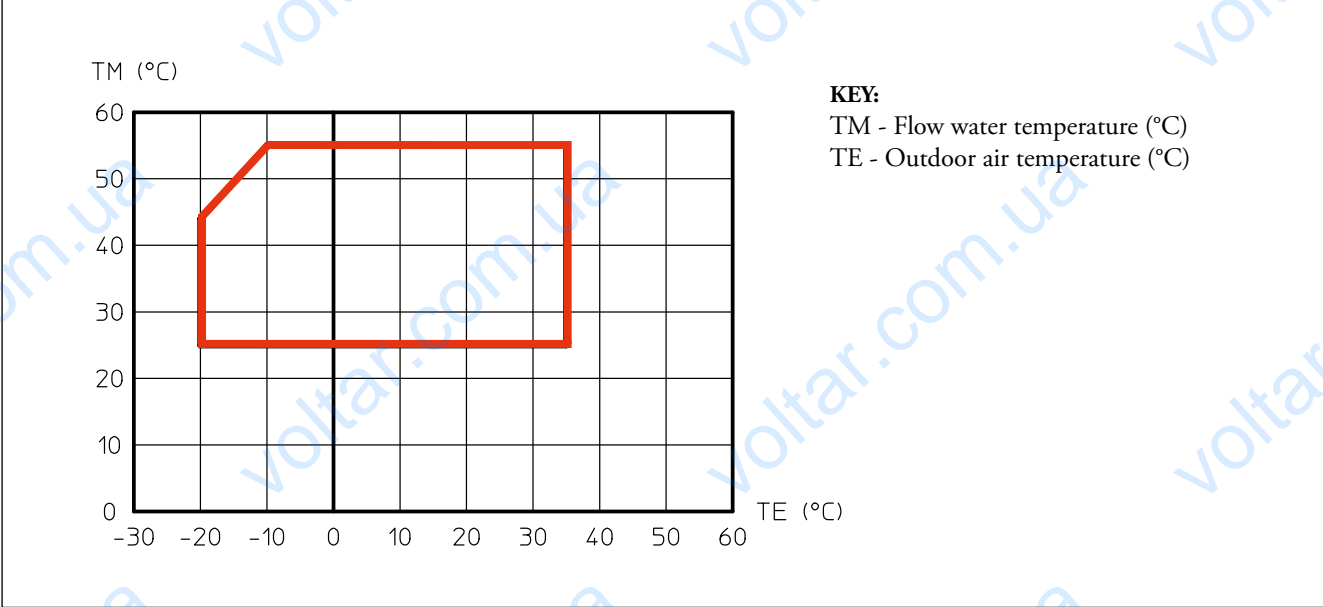

Cooling

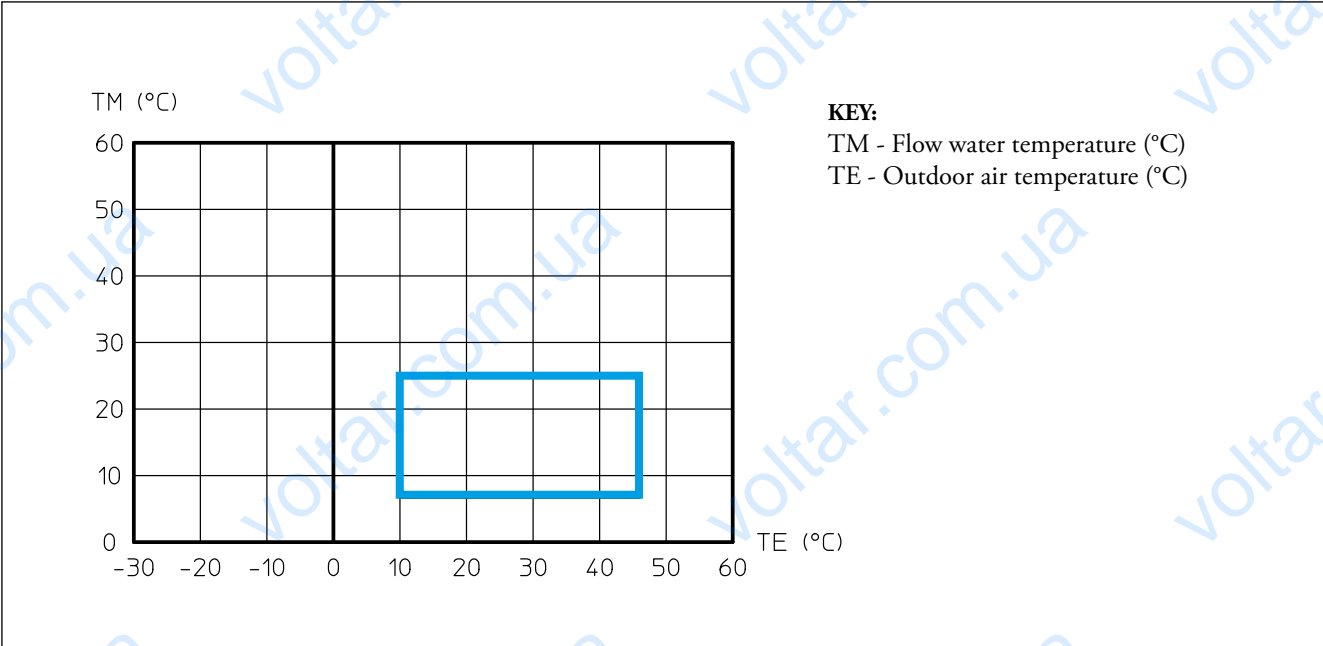

MAGIS COMBO

8

MAGIS COMBO MAIN COMPONENTS

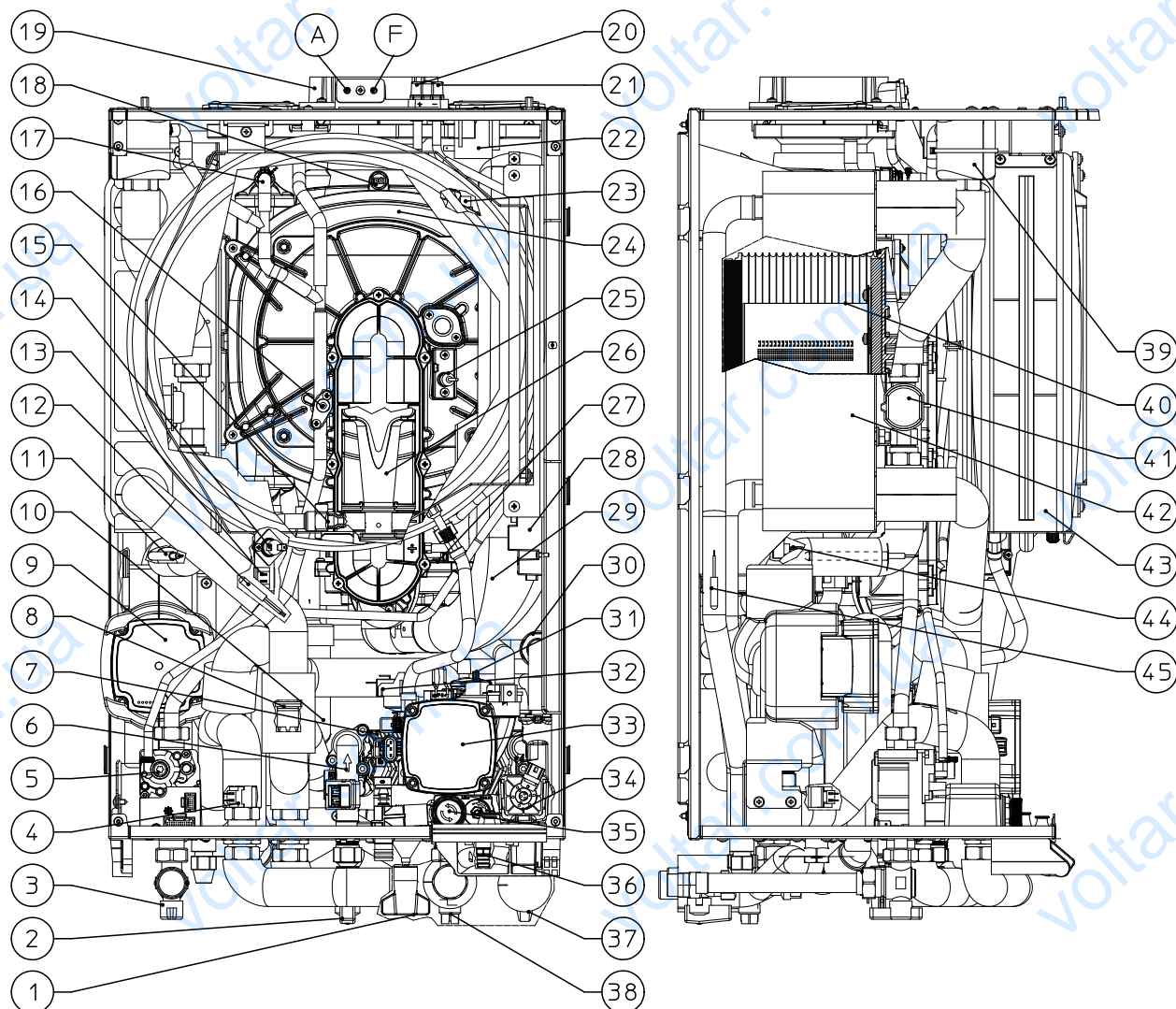

KEY:

- | | | |
|-----------------------------------|---|-----------------------------------|
| 1 - System filling cock | 18 - Flue safety thermostat | 35 - 3 bar safety valve |
| 2 - Domestic hot water inlet cock | 19 - Sample points (air A) - (flue gas F) | 36 - System draining cock |
| 3 - Gas interception cock | 20 - Positive signal pressure point | 37 - System interception cock |
| 4 - D.H.W. probe | 21 - Negative signal pressure point | 38 - System interception cock |
| 5 - Gas valve | 22 - Communication board transformer | 39 - Air vent valve |
| 6 - D.H.W. flow switch | 23 - Heat exchanger safety thermofuse | 40 - Burner |
| 7 - D.H.W. heat exchanger | 24 - Condensation module | 41 - System flow-meter |
| 8 - One-way valve | 25 - Ignition electrode | 42 - Water - gas plate exchanger |
| 9 - Heat pump circuit circulator | 26 - Venturi | 43 - System expansion vessel |
| 10 - Condensate drain trap | 27 - Fan | 44 - Heat generator return probe |
| 11 - Heat pump return probe | 28 - Igniter | 45 - Liquid phase detection probe |
| 12 - Heat pump flow probe | 29 - Air intake pipe | |
| 13 - Heat generator flow probe | 30 - One-way valve | |
| 14 - Safety thermostat | 31 - Air vent valve | |
| 15 - Gas nozzle | 32 - System pressure switch | |
| 16 - Detection electrode | 33 - Heat generator circuit circulator | |
| 17 - Manual air vent valve | 34 - Motorised 3-way valve | |

MAGIS COMBO PLUS MAIN COMPONENTS

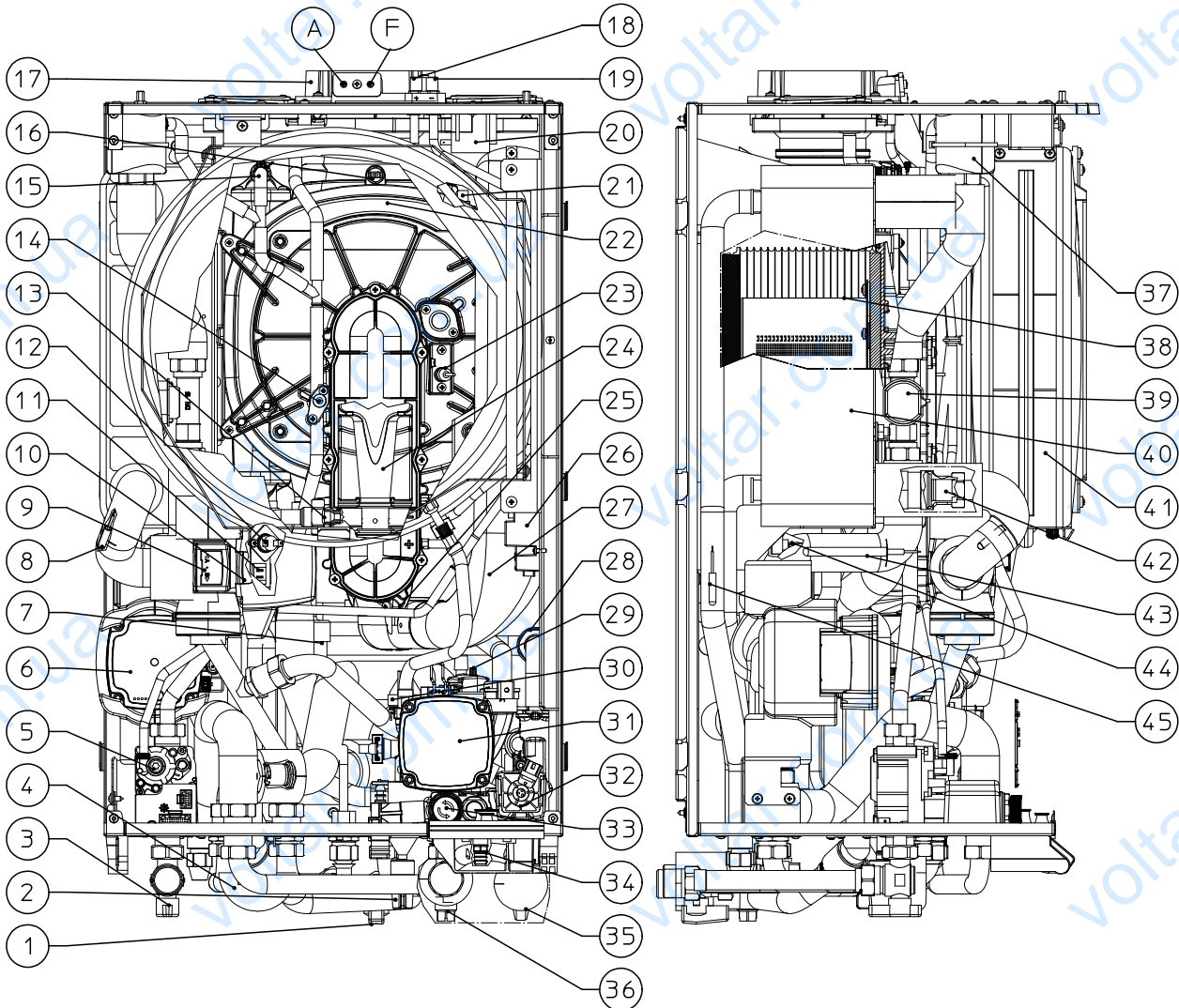

KEY:

- | | | |
|---|--|-----------------------------------|
| 1 - System filling cock | 20 - Communication board transformer | 39 - System flow-meter |
| 2 - Domestic hot water inlet cock | 21 - Heat exchanger safety thermofuse | 40 - Water - gas plate exchanger |
| 3 - Gas interception cock | 22 - Condensation module | 41 - System expansion vessel |
| 4 - Bypass pipe | 23 - Ignition electrode | 42 - One-way valve |
| 5 - Gas valve | 24 - Venturi | 43 - Heat pump return probe |
| 6 - Heat pump circuit circulator | 25 - Fan | 44 - Heat generator return probe |
| 7 - Condensate drain trap | 26 - Igniter | 45 - Liquid phase detection probe |
| 8 - Heat pump flow probe | 27 - Air intake pipe | |
| 9 - Heat pump 3-way valve | 28 - One-way valve | |
| 10 - 3-way valve motor | 29 - Air vent valve | |
| 11 - Heat generator flow probe | 30 - System pressure switch | |
| 12 - Safety thermostat | 31 - Heat generator circuit circulator | |
| 13 - Gas nozzle | 32 - Heat generator 3-way valve | |
| 14 - Detection electrode | 33 - 3 bar safety valve | |
| 15 - Manual air vent valve | 34 - System draining cock | |
| 16 - Flue gas thermofuse | 35 - System interception cock | |
| 17 - Sample points (air A) - (flue gas F) | 36 - System interception cock | |
| 18 - Positive signal pressure point | 37 - Air vent valve | |
| 19 - Negative signal pressure point | 38 - Burner | |

MAGIS COMBO

10

GRAPH OF HEAT PUMP FLOW RATE/HEAD

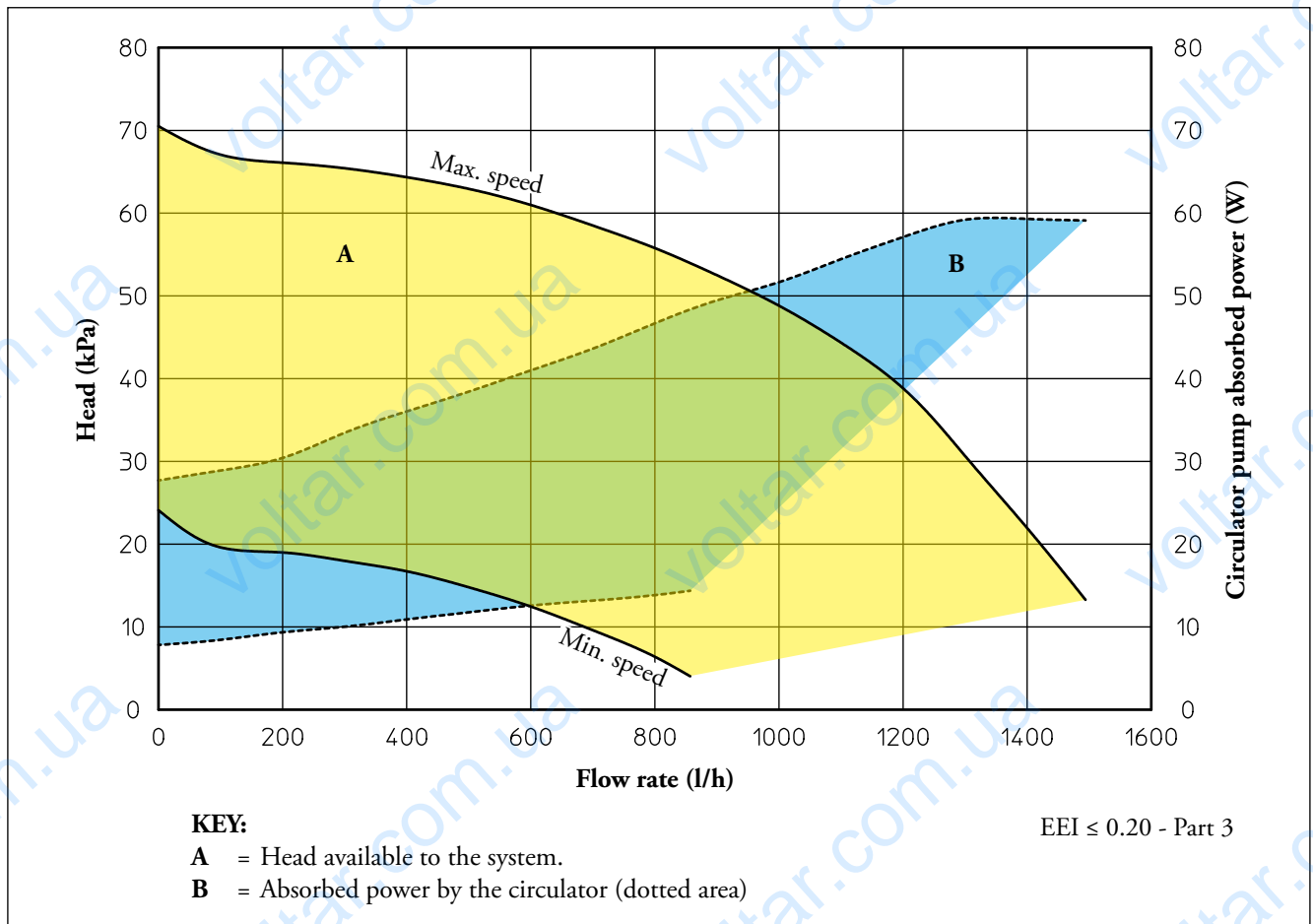

10.1 GRUNDFOS UPM3 K 15-75 PUMP SETTINGS AND CONFIGURATIONS

The indoor units are equipped with low power consumption pump with variable speed control associated with the heat pump operation (chiller circuit).

The pump speed is set via the following parameters:

Fixed ("A 05" = 0): the pump speed varies according to the power emitted by the generator, the greater the power the greater the speed. Also, you can adjust the pump operating range, by setting the maximum speed "A 04" and the minimum speed "A 03".

ΔT constant ("A 05" = 5 ÷ 25 K): the pump speed varies to maintain the ΔT (5K) constant between the system flow and return. Also, you can adjust the pump operating range, by setting

the maximum speed "A 04" and the minimum speed "A 03".

NOTE: for proper system operation, make sure that the minimum flow rate in operating conditions never drops below 500 l/h.

Treating the supply water allows you to prevent problems and maintain the functionality and efficiency of the generator over time.

Legislative Decree 26/06/2015 requires a chemical treatment of the thermal system water, in compliance with the UNI 8065 standard, in the cases provided for by the Decree.

TECHNICAL NOTE: System minimum water content:

To facilitate proper execution of the heat pump defrost cycles, a minimum water content in the system is required, which must be: 7 l kW of the machine's power for any type of system. So attention must be paid to the systems divided over several zones, where the water content available to the machine changes continuously. This is why it may be necessary to provide a heating flywheel that guarantees normal operation with systems divided into zones (with variable water content in circulation). This minimum content also guarantees proper operation with fan coils used for cooling (a condition in which the flow temperature is very low and has significant heat load variations that vary the number of active fan coils). It is also important to check that the dehumidifier line has a minimum of 3 l kW of the machine (dehumidifier hydraulic circuit connection).

11 GRAPH OF HEAT GENERATOR PUMP FLOW RATE/HEAD

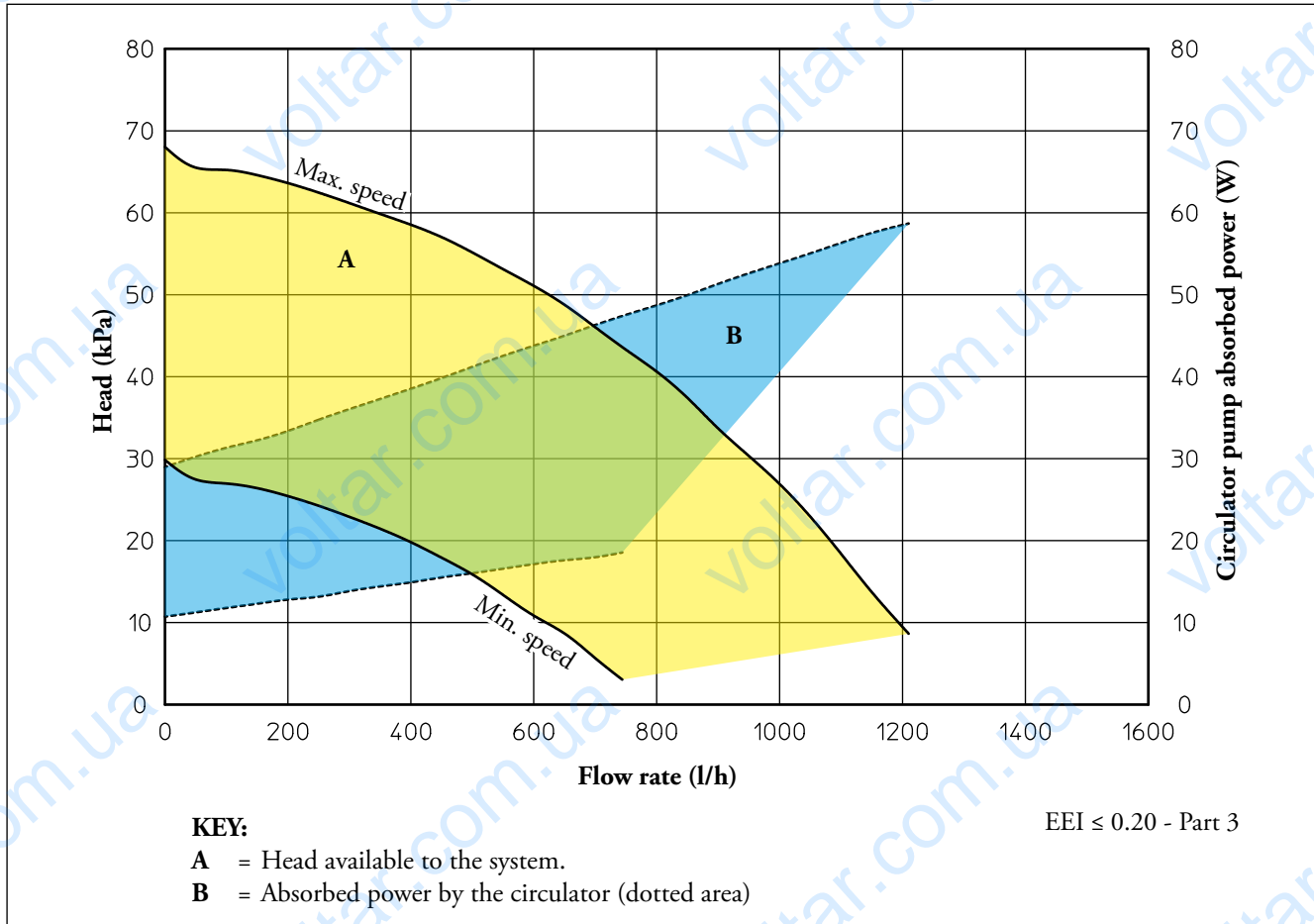

11.1 GRUNDFOS UPM3 15-70 PUMP SETTINGS AND CONFIGURATIONS

The indoor units are equipped with low power consumption pump with variable speed control associated with the condensation generator operation (heat generator).

The pump speed is set via the following parameters:

Fixed ("A 05" = 0): the pump speed varies according to the power emitted by the burner, the greater the power the greater the speed. Also, you can adjust the pump operating range, by setting the maximum speed "A 19" and the minimum speed "A 18".

ΔT constant ("A 05" = 5 ÷ 25 K): the pump speed varies to maintain the ΔT constant between the system flow and return. Also, you can adjust the pump operating range, by setting the maximum speed "A 19" and the minimum speed "A 18".

NOTE: for proper system operation, make sure that the minimum flow rate in operating conditions never drops below 500 l/h.

Treating the supply water allows you to prevent problems and maintain the functionality and efficiency of the generator over time.

Legislative Decree 26/06/2015 requires a chemical treatment of the thermal system water, in compliance with the UNI 8065 standard, in the cases provided for by the Decree.

TECHNICAL NOTE: System minimum water content:

To facilitate proper execution of the heat pump defrost cycles, a minimum water content in the system is required, which must be: 7 l kW of the machine's power for any type of system. So attention must be paid to the systems divided over several zones, where the water content available to the machine changes continuously. This is why it may be necessary to provide a heating flywheel that guarantees normal operation with systems divided into zones (with variable water content in circulation). This minimum content also guarantees proper operation with fan coils used for cooling (a condition in which the flow temperature is very low and has significant heat load variations that vary the number of active fan coils). It is also important to check that the dehumidifier line has a minimum of 3 l kW of the machine (dehumidifier hydraulic circuit connection).

MAGIS COMBO

12

MAGIS COMBO HYDRAULIC DIAGRAM

KEY:

- 1 - D.H.W. flow switch
- 2 - Condensate drain trap
- 3 - Gas valve
- 4 - Gas valve outlet pressure point (P3)
- 5 - Liquid phase detection probe
- 6 - D.H.W. probe
- 7 - System filling cock
- 8 - D.H.W. heat exchanger
- 9 - System expansion vessel
- 10 - Heat pump flow probe
- 11 - Water - gas plate exchanger
- 12 - Air vent valve
- 13 - Fan
- 14 - Air/gas Venturi manifold
- 15 - Gas nozzle
- 16 - Detection electrode
- 17 - Burner
- 18 - Flue safety thermostat
- 19 - Air intake pipe
- 20 - Manual air vent valve
- 21 - Heat exchanger safety thermofuse
- 22 - Air sample point
- 23 - Flue sample point
- 24 - ΔP gas pressure point
- 25 - Fumes hood
- 26 - Safety thermostat
- 27 - Heat generator flow probe
- 28 - Heat generator return probe
- 29 - Ignition electrodes
- 30 - Venturi negative signal (P2)
- 31 - Venturi positive signal (P1)
- 32 - System flow-meter
- 33 - One-way valve
- 34 - One-way valve
- 35 - Heat pump return probe
- 36 - Air vent valve
- 37 - Heat generator circuit circulator
- 38 - Heat pump circuit circulator
- 39 - System pressure switch
- 40 - Motorised 3-way valve
- 41 - System draining cock
- 42 - 3 bar safety valve
- 43 - System interception cock
- 44 - System interception cock with inspectable filter

- G - Gas supply
- SC - Condensate drain
- LP - Chiller line - liquid phase
- GP - Chiller line - gaseous phase
- AC - Domestic hot water outlet
- AF - Domestic hot water inlet
- R - System return
- M - System flow

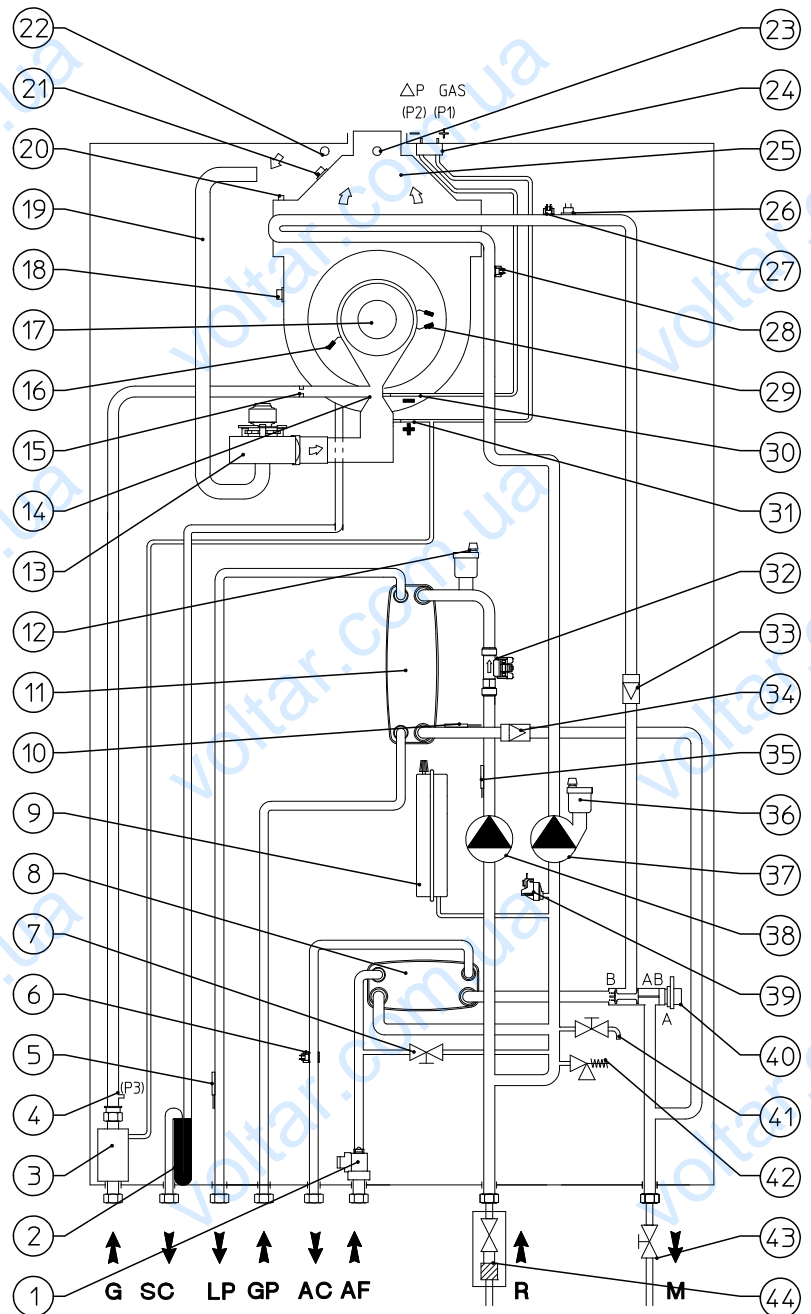

13

MAGIS COMBO PLUS HYDRAULIC DIAGRAM

KEY:

- 1 - 3 bar safety valve
 - 2 - Condensate drain trap
 - 3 - Gas valve
 - 4 - Gas valve outlet pressure point (P3)
 - 5 - Liquid phase detection probe
 - 6 - System draining cock
 - 7 - System pressure switch
 - 8 - System expansion vessel
 - 9 - Heat generator circuit circulator
 - 10 - Air vent valve
 - 11 - One-way valve
 - 12 - Water - gas plate exchanger
 - 13 - Fan
 - 14 - Air/gas Venturi manifold
 - 15 - Gas nozzle
 - 16 - Detection electrode
 - 17 - Burner
 - 18 - Flue gas thermofuse
 - 19 - Air intake pipe
 - 20 - Manual air vent valve
 - 21 - Heat exchanger safety thermofuse
 - 22 - Air sample point
 - 23 - Flue sample point
 - 24 - ΔP gas pressure point
 - 25 - Fumes hood
 - 26 - Safety thermostat
 - 27 - Heat generator flow probe
 - 28 - Heat generator return probe
 - 29 - Ignition electrodes
 - 30 - Venturi negative signal (P2)
 - 31 - Venturi positive signal (P1)
 - 32 - Air vent valve
 - 33 - One-way valve
 - 34 - System flow-meter
 - 35 - Heat pump return probe
 - 36 - Heat pump 3-way valve
 - 37 - Heat pump flow probe
 - 38 - Heat pump circuit circulator
 - 39 - Heat generator 3-way valve
 - 40 - System filling cock
 - 41 - System filling
 - 42 - System interception cock
 - 43 - System interception cock
-
- G - Gas supply
 - SC - Condensate drain
 - LP - Chiller line - liquid phase
 - GP - Chiller line - gaseous phase
 - RU - Storage tank unit return
 - MU - Storage tank unit flow
 - RR - System filling
 - R - System return
 - M - System flow

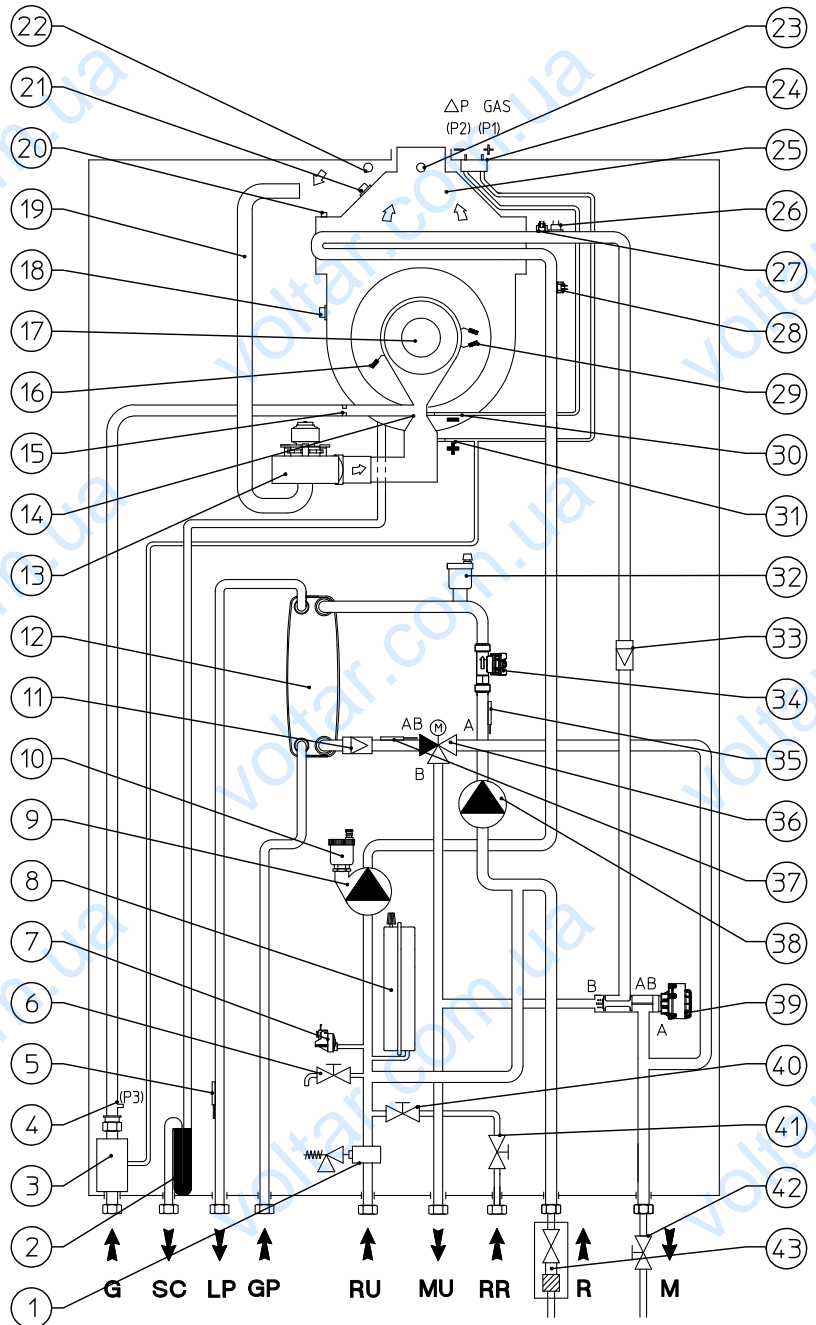

MAGIS COMBO

14 HYDRAULIC DIAGRAM AUDAX PRO (EXTERNAL CONDENSING UNIT)

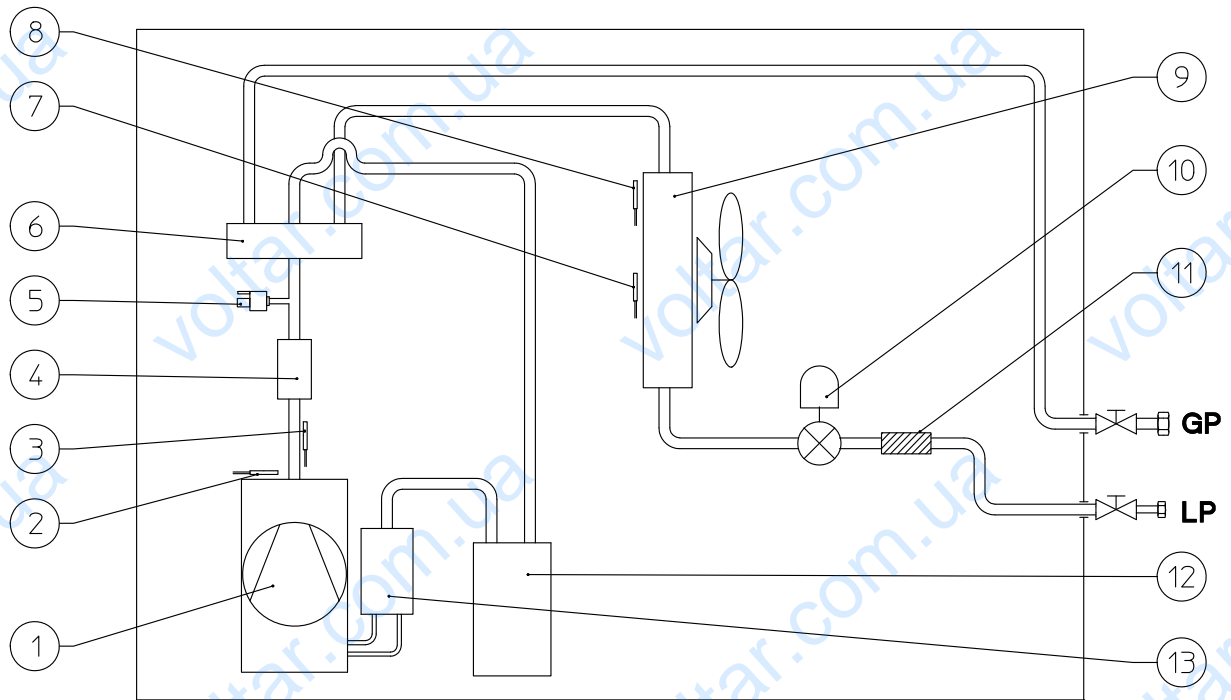

KEY:

- 1 - Compressor
- 2 - Compressor temperature
- 3 - Compressor outlet temperature
- 4 - Silencer
- 5 - High pressure switch
- 6 - 4-way valve
- 7 - Temperature of fluid in finned coil
- 8 - External probe/installation room temperature
- 9 - Finned coil + fan
- 10 - Electronic expansion valve
- 11 - Dryer filter
- 12 - Liquid receiver
- 13 - Liquid separator

LP - Chiller line - liquid phase
 GP - Chiller line - gaseous phase



The electronic of MAGIS COMBO is characterised by an integrated intelligent management system that establishes the most beneficial operating priority of the generator between Heat Pump or condensation unit, on the basis of the external climatic conditions and central heating system flow temperature set.

MAGIS COMBO works with variable temperature, using the external probe on the condensing unit (placed outdoors).

It is arranged to directly manage 2 zones (one direct and one mixed) for operation in both heating and cooling, with the possibility of setting 2 curves in hot and 2 curves in cold (for the 2 zones) without the need to provide the System manager. In this case, MAGIS COMBO can work with one or two CAR^{V2} (or CHRONO 7) to control the room temperature of the 2 zones; 2 humidistats (code 3.023302) or 2 temperature and humidity sensors (code 3.021524) can be connected to control humidity. With regard to the temperature and humidity sensor, only connect the humidity sensor part since the temperature is detected via the CAR^{V2}.

The relative humidity set is set on CAR^{V2} (parameter S RH %, adjustable from 20 to 90%, default 60%), or on the MAGIS COMBO display.

The temperature detected via CAR^{V2} is also used to calculate the dew point (if I do not use the CAR^{V2} I cannot calculate the dew point temperature).

To control the dehumidifiers, fit the wall-hung indoor unit with a 2 relay board kit (optional), for the respective dehumidifiers of the 2 zones; the kit allows activating the dehumidifiers via a potential free contact.

There is an input for system activation in correspondence of electricity production by the photovoltaic system (if installed).

This input (when active) forces the heating of a storage tank for the production of DHW at maximum temperature (if the storage tank is present e.g. MAGIS COMBO PLUS), to then meet any system demands.

It includes a 230 V output to control summer/winter diverter valves in heating systems with fan coil cold/radiant panels; switching occurs with the change of mode (summer/winter) from the control panel or from CAR^{V2}.

The electronic of MAGIS COMBO PLUS also manages the anti-legionella function through the CAR^{V2}.

In the presence of any "Puffer" which is heated by another energy source (e.g. thermal chimney), it is possible to connect the electronics with a temperature control probe (code 3.019375), exceeded the required temperature MAGIS COMBO remains off, but the system zones can continue to operate (obviously in the presence of requests).

Whereas, to control a possible solar system, a solar control unit is required (to be purchased separately).

The integrated electronics also manage the screed heating function in order to perform the initial central heating cycle on new radiant panel systems.

MAGIS COMBO

15.1

USER PROGRAMMING MENU

DATA MENU		
Id Parameter	Description	Range
D 01	Combustion signal	0 ÷ 99 µA
D 02	Heat generator primary exchanger outlet instant heating flow temperature	0 ÷ 99 °C
D 03	Displays the Instant output temperature from the DHW exchanger / Displays the storage tank unit temperature	0 ÷ 99 °C
D 04	Value calculated for system setting	7 ÷ 80 °C
D 05	Value set for DHW setting	10 ÷ 65 °C
D 06	Outdoor temperature (if the condensing unit external probe is connected or if the optional external probe is available)	- 20 ÷ 50 °C
D 07	D.H.W. input temperature (only in instant COMBO version if probe is present)	0 ÷ 99 °C
D 08	Heat pump return water temperature	0 ÷ 99 °C
D 09	List of the last five anomalies (to scroll the list press "OK")	-
D 10	Anomaly list reset. Once displayed "D 10" press the button "OK"	-
D 12	Heat generator pump operating speed	0 ÷ 100 %
D 13	DHW instant flow rate (only in the Instant COMBO version)	OFF - ON
D 14	System circulator flow rate (l/h)	0 ÷ 9999 l/h
D 15	Fan operating speed	0 ÷ 9999 rpm
D 20	Heat pump primary exchanger outlet instant flow temperature	0 ÷ 99 °C
D 22	Heat generator 3-way (DHW = domestic hot water, CH = central heating)	DHW - CH
D 23	Heat generator return water temperature	0 ÷ 99 °C
D 24	Chiller circuit liquid temperature	-20 ÷ 99 °C
D 25	Zone 2 flow temperature (if configured)	0 ÷ 99 °C
D 26	Probe for primary solar storage (puffer)	0 ÷ 99 °C
D 27	System pressure switch	OFF - ON
D 28	System circulator instantaneous speed	0 ÷ 100 %
D 29	Not used	-
D 31	Not used	-
D 32	Not used	-
D 33	D.H.W. integration 3-way (only in the COMBO PLUS version)	OFF - ON
D 34	Heat pump disabling	OFF - ON
D 35	Solar system inlet	OFF - ON
D 36	Not used	-
D 41	Zone 1 relative humidity	0 ÷ 99 %
D 42	Zone 2 relative humidity	0 ÷ 99 %
D 43	Zone 1 humidistat	OFF - ON
D 44	Zone 2 humidistat	OFF - ON
D 45	Dehumidifier zone 1	OFF - ON
D 46	Dehumidifier zone 2	OFF - ON
D 47	Zone 1 circulator pump	OFF - ON
D 48	Zone 2 circulator pump	OFF - ON
D 49	Central heating / cooling system separation 3-way (CL = cooling, HT = heating)	CL - HT
D 51	Zone 1 remote control	OFF - ON
D 52	Zone 2 remote control	OFF - ON
D 53	System setting with remote connection in zone 1	0 ÷ 99 °C
D 54	System setting with remote connection in zone 2	0 ÷ 99 °C

DATA MENU		
Id Parameter	Description	Range
D 55	Zone 1 thermostat	OFF - ON
D 56	Zone 2 thermostat	OFF - ON
D 61	Appliance model definition	MC - MCP
D 62	Communication with outdoor condensing unit	OFF - ON
D 63	Communication with other Immergas devices	OFF - ON
D 71	Condensing unit operating frequency	0 ÷ 150 Hz
D 72	Condensing unit compressor temperature	-20 ÷ 200 °C
D 73	Compressor outlet instantaneous temperature	-20 ÷ 100 °C
D 74	Evaporator coil temperature	-20 ÷ 100 °C
D 75	Condensing unit compressor absorption	0 ÷ 10 A
D 76	Condensing unit fan speed	0 ÷ 100 rpm
D 77	Electronic expansion valve position	0 ÷ 500
D 78	4-way side (CL = cooling, HT = heating)	HT / CL
D 79	Temperature detected by the condensing unit external probe	-55 ÷ +45 °C
D 80	Heat pump status	0 ÷ 8
D 91	P.C.B. software version	
D 92	Ignition board software version	
D 97	Heat pump request state	0 ÷ 999
D 98	Heat generator request state	0 ÷ 999
D 99	System state	0 ÷ 999

USER MENU			
Id Parameter	Description	Range	Default
U 01	Zone 2 heating setting	25 ÷ 80 °C	25
U 02	Zone 2 cooling setting	7 ÷ 25 °C	20
U 03	Zone 1 central heating offset	You can edit the flow temperature with respect to the external probe regulation curve in central heating mode (see heat adjustment graphs).	- 15 ÷ + 15 °C
U 04	Zone 2 central heating offset		
U 05	Zone 1 cooling offset	You can edit the flow temperature with respect to the external probe regulation curve in cooling mode (see heat adjustment graphs).	- 15 ÷ + 15 °C
U 06	Zone 2 cooling offset		
U 07	Zone 1 humidity setting	The humidity temperature sensor (optional) defines room humidity in the corresponding area.	30 ÷ 70 °C
U 08	Zone 2 humidity setting		
U 11	Night function	This function can only be activated if CAR ^{V2} (optional) is available. Activating the function allows you to reduce the compressor frequency during the condensing unit operation in the time slot set in the U 12 and U 13 parameters. Make sure the additional power sources needed to meet potential requirements that may present themselves during active operation are available.	OFF - ON
U 12	Night function enabling time		0 ÷ 23
U 13	Night function disabling time		0 ÷ 23

N.B.: The parameters referring to zone 2 can only be displayed if there is a zone 2 on the system and it is configured correctly.

MAGIS COMBO

15.2 MAINTENANCE TECHNICIAN PROGRAMMING MENU

Id Parameter	Parameter	Description	Range	Default
A 03	Heat pump circulator minimum speed	Defines the minimum operating speed of the heat pump circulator.	45 ÷ 100 %	70
A 04	Heat pump circulator maximum fixed speed	Defines the maximum operating speed of the heat pump circulator.	45 ÷ 100 %	100
A 05	Circulator mode	- 0 = Fixed - 5 ÷ 25K ΔT Constant	0 - 25	0
A 11	Condensing unit model	Establishes the outdoor condensing unit model. If set to OFF, only the integrated generators are activated.	OFF - 5 - 8 - 10	8
A 12	System vent	Enables the automatic vent function. This function activates as soon as the unit is powered.	OFF - ON	ON
A 13	Number of zones	Defines the number of zones in the heating system.	1 - 2	1
A 16	Zone 1 humidity sensor	Humidity temperature sensor / Humidistat. Defines the type of control on zone 1 humidity.	SE = Humidity temp. sensor ST = Humidistat	ST
A 17	Zone 2 humidity sensor	Humidity temperature sensor / Humidistat. Defines the type of control on zone 2 humidity.	SE = Humidity temp. sensor ST = Humidistat	ST
A 18	Heat generator minimum circulator speed	Defines the minimum operating speed of the heat generator circulator.	55 ÷ 100 %	75
A 19	Heat generator maximum fixed circulator speed	Defines the maximum operating speed of the heat generator circulator.	55 ÷ 100 %	100
A 21	BMS communication address	Defines the communication protocol between the indoor unit and the condensing unit.	1 ÷ 247	11
A 22	BMS communication setting	OFF = BMS communication protocol on 485; use if connected to optional Immergas devices. 485 = Do not use UC = Do not use	OFF - 485 - UC	OFF

Id Parameter	Parameter	Description	Range	Default
P 00	DHW max	Defines the maximum heat output percentage of the heat generator during the D.H.W. phase compared to the maximum heat output available.	0 - 100 %	100%
P 01	Min C.H.	Defines the minimum heat output percentage of the heat generator during the C.H. phase compared to the maximum heat output available.	0 - P2	0%
P 02	Heating max	Defines the maximum heat output percentage of the heat generator during the C.H. phase compared to the maximum heat output available.	0 - 100%	According to the heat generator model
P 03	Relay 1 (optional)	The indoor unit is set-up for functioning with the relay P.C.B. (optional), which can be configured. 0 = Off 1 = DHW recirculation 2 = General alarm 3 = Central heating / cooling mode active 4 = Puffer mode active	0 ÷ 4	0
P 04	Relay 2 (optional)	The indoor unit is set-up for functioning with the relay P.C.B. (optional), which can be configured. 0 = Off 1 = DHW recirculation 2 = General alarm 3 = Central heating / cooling mode active 4 = Puffer mode active	0 ÷ 4	0
P 05	Relay 3 (optional)	The indoor unit is set-up for functioning with the relay P.C.B. (optional), which can be configured. 0 = Off 1 = DHW recirculation 2 = General alarm 3 = Central heating / cooling mode active 4 = Puffer mode active	0 ÷ 4	0
P 06	Pump functioning	The pump can function in two ways. IN (intermittent): in "winter" mode, the circulator is managed by the room thermostat or by the remote control. CO (continuous): in "winter" and "cooling" mode, the circulator is always powered and is, therefore, always in operation.	IN - CO	IN
P07	External probe correction	If the reading of the external probe is not correct it is possible to correct it in order to compensate any environmental factors. (Over the value of +20 the display shows "CE", which enables an external control function of the boiler for coupling of the same with a system supervisor).	-20 ÷ 20 K	0

MAGIS COMBO

Id Parameter	Parameter	Description	Range	Default
T 02	D.H.W. thermostat (only for instant COMBO)	Establishes the switch-off method in DHW mode. 1 Correlated: the boiler switches off according to the temperature set. 0 Fixed: the switch-off temperature is fixed at the maximum value regardless of the value set on the control panel.	0 - 1	0
T 02	D.H.W. thermostat (only for COMBO PLUS)	Establishes the unit ignition and switch-off mode in DHW. It is enabled when the water in the storage tank goes below the DHW set value and is disabled when the temperature exceeds the DHW set value.	0 - 20	4
T 03	Solar delay timing (only for instant COMBO)	The generator is set to switch-on immediately after a request for DHW. In the case of coupling with a solar storage tank positioned upstream from the product, it is possible to compensate the distance between the storage tank and the generator in order to allow the hot water to reach the heat generator. Set the time necessary to verify that the domestic hot water is hot enough.	0 - 30 seconds	0
T 04	Domestic hot water priority timing (only for instant COMBO)	In winter mode the heat generator, at the end of a domestic hot water request, is ready to switch to central heating mode if there is an active request. Timing sets a time period in which the heat generator waits before changing the operating mode, in order to quickly and comfortably satisfy an additional request for domestic hot water.	0 - 100 seconds (step 10 sec)	20
T 05	Central heating ignitions timer	The condensation generator has an electronic timer, which prevents the generator from igniting too often in central heating mode.	0 - 10 minutes	3
T 06	Central heating ramp timer	In the heating stage, the condensation generator performs an ignition ramp in order to reach the maximum output set.	0 - 14 minutes	3
T 07	Delay request from TA	The system is set to switch on immediately after a request for room heating/air conditioning. For special systems (e.g. zone systems with motorised valves, etc.), it may be necessary to delay ignition.	0 - 240 seconds (step 10 sec)	0
T 08	Display lighting	Establishes the display lighting mode. AU: the display lights up during use and lowers after 15 seconds of inactivity. In the event of an anomaly, the display flashes. OFF: the display lighting is always off. ON: the display lighting is always on.	AU - OFF - ON	AU
T 09	Display	Establishes what the indicator displays. "Summer" mode: ON: pump active displays the flow temperature, pump off the indicator is off. OFF: the indicator is always off. "Winter" and "cooling" mode: ON: pump active displays the flow temperature, pump off the indicator is off. OFF: pump active displays the value set on the heating/cooling selector, with circulator off the indicator is off.	ON - OFF	ON
T 11	Do not use	-	0 ÷ 36	0
T 21	Screed heating - minimum temperature	Defines the time spent at minimum operating temperature during the active function.	0 ÷ 7 days	3
T 22	Screed heating - ascent gradient	Defines the ascent gradient of the temperature.	0 ÷ 30	30
T 23	Screed heating - maximum temperature	Defines the time spent at maximum operating temperature during the active function.	0 ÷ 14 days	4
T 24	Screed heating - descent gradient	Defines the descent gradient of the temperature.	0 ÷ 30	30

HEAT REGULATION MENU				
Id Parameter	Parameter	Description	Range	Default
R 01	External probe	Defines if and which external probe is used to manage the system. OFF = no external probe used OU = external probe on the outdoor condensing unit IU = optional external probe connected to the indoor unit	OFF - OU - IU	OU
R 02	Outdoor temperature for max. CH flow	Establishes the outdoor temperature at which to have the maximum flow temperature.	-15 ÷ 25 °C	-5
R 03	Outdoor temperature for min. CH flow	Establishes the outdoor temperature at which to have the minimum flow temperature.	-15 ÷ 25 °C	25
R 04	Maximum central heating	Defines the maximum flow temperature in room central heating mode.	35 ÷ 80	55
R 05	Minimum central heating	Defines the minimum flow temperature in room central heating mode.	20 ÷ 35	25
R 06	Outdoor temperature for low temperature zone max. CH flow	Establishes the outdoor temperature at which to have the maximum flow temperature in the low temperature zone.	-15 ÷ 25 °C	-5
R 07	Outdoor temperature for low temperature zone min. CH flow	Establishes the outdoor temperature at which to have the minimum flow temperature in the low temperature zone.	-15 ÷ 25 °C	25
R 08	Low temperature zone maximum central heating	Defines the maximum flow temperature in room central heating mode in the low temperature zone.	35 ÷ 80	45
R 09	Low temperature zone minimum central heating	Defines the minimum flow temperature in room central heating mode in the low temperature zone.	20 ÷ 35	25
R 10	Outdoor temperature for minimum cooling flow	Establishes the maximum outdoor temperature at which to have the minimum flow temperature in cooling mode.	20 ÷ 40	35
R 11	Outdoor temperature for maximum cooling flow	Establishes the minimum outdoor temperature at which to have the maximum flow temperature in cooling mode.	20 ÷ 40	25
R 12	Minimum cooling	Defines the minimum flow temperature in room cooling mode.	7 ÷ 20	7
R 13	Maximum cooling	Defines the maximum flow temperature in room cooling mode.	7 ÷ 25	12
R 14	Outdoor temperature for low temperature zone minimum cooling flow	Establishes the outdoor temperature at which to have the minimum flow temperature in the low temperature zone.	20 ÷ 40	35
R 15	Outdoor temperature for low temperature zone max. cooling flow	Establishes the outdoor temperature at which to have the maximum flow temperature in the low temperature zone.	20 ÷ 40	25
R 16	Low temperature zone minimum cooling	Defines the minimum flow temperature in room cooling mode in the low temperature zone.	7 ÷ 20	18
R 17	Low temperature zone maximum cooling	Defines the maximum flow temperature in room cooling mode in the low temperature zone.	7 ÷ 25	20

N.B.: see also the graphs on the next pages.

MAGIS COMBO

INTEGRATION MENU				
Id Parameter	Parameter	Description	Range	Default
I 01	DHW integration enabling	Allows you to enable an alternative power source (AL) to integrate domestic hot water heating.	OFF - AL	AL
I 02	System integration enabling	Using this function, you can enable an alternative (AL) power source to integrate heating system central heating.	OFF - AL	AL
I 03	DHW max. wait time (only for COMBO PLUS)	Establishes the maximum amount of time before activating DHW integration.	0 - 255 minutes (in 1 minute steps)	30
I 04	Central heating max. wait time	Establishes the maximum amount of time before activating central heating integration.	0 - 255 minutes (in 1 minute steps)	45
I 05	Integration activation mode	Establishes how to integrate the heat generator to the condensing unit, you can choose between "AU" automatic and "MA" manual.	AU - MA	AU
I 06	Manual activation temperature	Establishes the outdoor temperature under which central heating integration is enabled.	-15 ÷ 20 °C	-5
I 07	Activation band		0 ÷ 10 °C	5
I 08	Simultaneous D.H.W.	Enables the simultaneous operation of D.H.W. mode and room air conditioning mode.	OFF - ON	OFF
I 11	Condensing unit hours of operation	Displays the hours of operation performed by the Condensing unit.	-	-
I 12	Indoor central heating unit hours of operation	Displays the hours of operation of the indoor central heating unit.	-	-
I 13	Indoor D.H.W. unit hours of operation	Displays the hours of operation of the indoor D.H.W. unit.	-	-

HEAT GENERATOR TEMPERATURE				
Id Parameter	Parameter	Description	Range	Default
S 00	DHW minimum no. of fan revs	Operating speed of the fan at minimum DHW output.	900 ÷ 1500 (in rpm x 50)	G20 = 1300 G30 = 1300 G31 = 1300
S 01	DHW maximum no. of fan revs	Operating speed of the fan at maximum DHW output.	3000 ÷ 6100 (in rpm x 50)	G20 = 5100 G30 = 4800 G31 = 5400
S 02	Ignition phase fan speed	Operating speed of the fan during the ignition phase.	0 ÷ 100%	15

MAINTENANCE MENU				
Id Parameter	Parameter	Description	Range	Default
M 01	Venting	In the case of new central heating systems and in particular mode for floor systems, it is very important that deaeration is performed correctly. The function consists of the cyclic activation of the pump (100 s ON, 20 s OFF) and the 3-way valve (120 s D.H.W., 120 s heating system). The function lasts for 18 hours and can be interrupted by pressing the "ESC" button and setting the function to "OFF".	OFF - ON	OFF
M 02	System circulator speed	Establishes the circulator speed linked to the heat pump generator.	0 - 100%	0
M 03	DHW 3-way	Moves the 3-way motor from system to DHW.	OFF - ON	OFF
M 04	Hot/cold 3-way	Moves the cooling/heating circuit 3-way motor (outside the device).	OFF - ON	OFF
M 06	Condensation generator circulator speed	Establishes the circulator speed linked to the condensation generator.	0 - 100%	0
M 07	DHW Integration 3-way (only for COMBO PLUS)	Moves the D.H.W. integration 3-way motor with Heat Pump.	OFF - ON	OFF
M 08	Zone 1 outdoor circulator	Enables the zone 1 outdoor circulator.	OFF - ON	OFF
M 09	Zone 2 outdoor circulator	Enables the zone 2 outdoor circulator.	OFF - ON	OFF
M 10	Mixer zone 2	Establishes zone 2 mixing valve positioning.	OFF - OPEN - CLOSE	OFF
M 11	DHW electrical resistance	NOT used.	-	-
M 12	Central heating electrical resistance	NOT used.	-	-
M 13	Dehumidifier zone 1	Enables the dehumidifier in zone 1.	OFF - ON	OFF
M 14	Dehumidifier zone 2	Enables the dehumidifier in zone 2.	OFF - ON	OFF
M 15	Relay 1	Enables relay 1 on the 3-relay board.	OFF - ON	OFF
M 16	Relay 2	Enables relay 2 on the 3-relay board.	OFF - ON	OFF
M 17	Relay 3	Enables relay 3 on the 3-relay board.	OFF - ON	OFF

MAGIS COMBO

By setting the parameters in the "Heat regulation" menu, you can adjust how the system operates.

The following graphs show the default settings in the various operating modes available both with external probe and without.

PLEASE NOTE: In case of use of the CARV², the heat adjustment curves, in the central heating phase only, are determined by the device itself.

Zone 1 flow temperature in central heating mode, with external probe

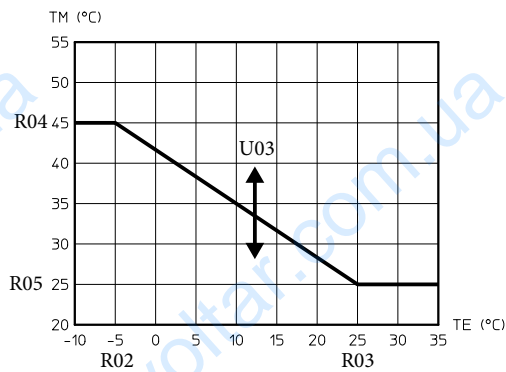

Zone 2 mixed flow temperature in central heating mode, with external probe

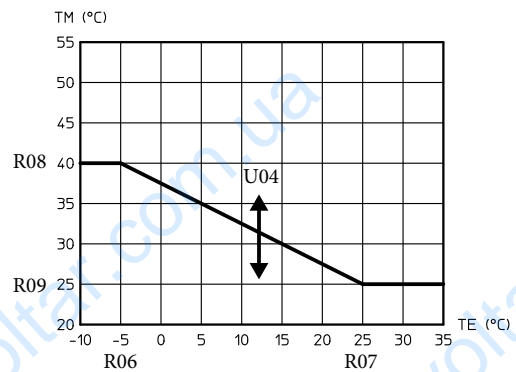

Zone 1 flow temperature in cooling mode, with external probe

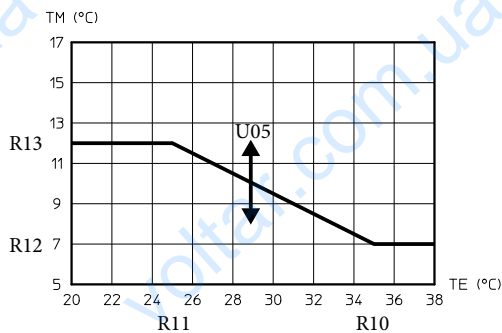

Zone 2 mixed flow temperature in cooling mode, with external probe

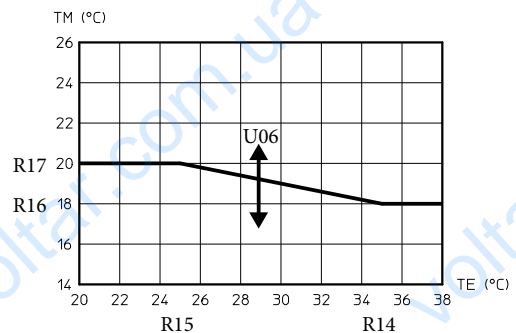

Flow temperature in central heating mode without external probe

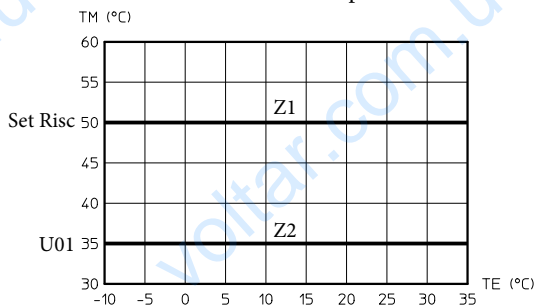

Flow temperature in cooling mode without external probe

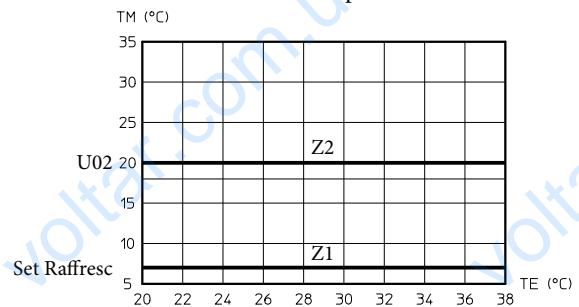

KEY:

- Rxx - "Heat regulation" menu parameter
- TE - Outside temperature
- TM - Flow temperature
- U01 - Zone 2 flow temperature in "User" menu central heating mode

- U02 - Zone 2 flow temperature in "User" menu cooling mode
- U03÷06 - Offset value compared to the curve set by the external probe
- Zx - Heating system zone

16

ELECTRIC CONNECTION CABLES FEATURES

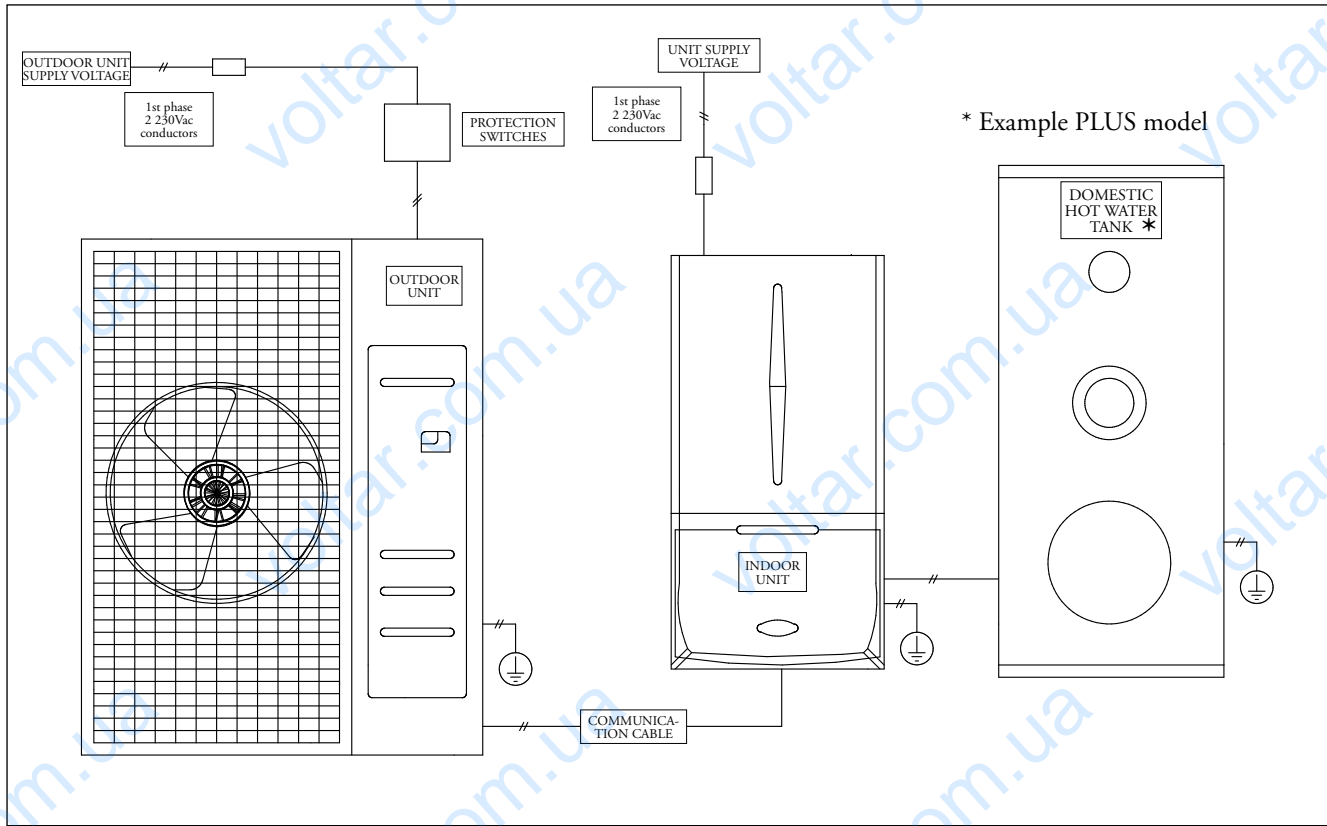

Features of the indoor unit connection. The outdoor unit power cable (not standard supplied) must be suitable for outdoor installation and must have at least a flexible polychloroprene sheath (code IEC:60245 IEC 57 / CENELEC:H05RN-F).

Indicatively, the appropriate cable section can be 2.5 mm², to be checked depending on the specific installation conditions.

Outdoor Unit	Nominal Values		Field of Tolerable Voltage		Maximum absorbed current (MAC) in normal operation	MAC*1.25 + Additional Load	Fuse capacity necessary for the unit
	Hz	V	V	V			
AUDAX PRO 5	50	220 - 240	198	264	20	25.0	30
AUDAX PRO 8 and 10	50	220 - 240	198	264	22	27.5	40

Features of the connection between outdoor and indoor units.

Use H07RN-F or H05RN-F class cables to power the indoor unit.

If the indoor unit is installed in a room with a computer or internet server, you must use a double shielded FROHH2R class cable (Aluminium tape/Polyester + Copper braid).

MAGIS COMBO Supply voltage			BUS Communication cable between outdoor unit and indoor unit
Power Supply	Max./Min.(V)	Connection cable	
Mono-phase, 220-240V, 50Hz	±10%	0,75 - 1.5 mm ² , 3 wires	0.75 - 1.5mm ² , 2 wires

MAGIS COMBO

17

OUTDOOR UNIT TERMINAL BLOCK ELECTRICAL CONNECTIONS

With use of the mono-phase safety switch (ELB).

Depending on the model, the actual appearance of the unit may differ from the one shown in the figure.

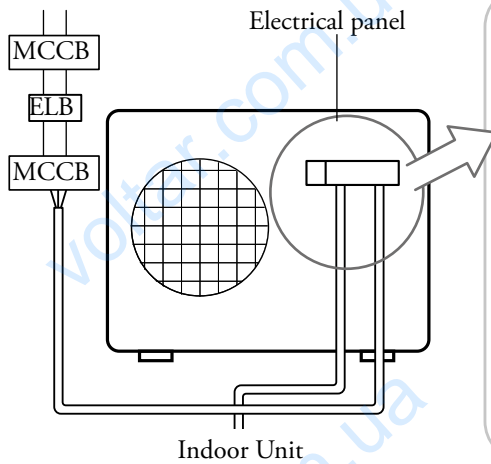

KEY:

- ELB - Safety Switch
- MCCB - Circuit breaker switch

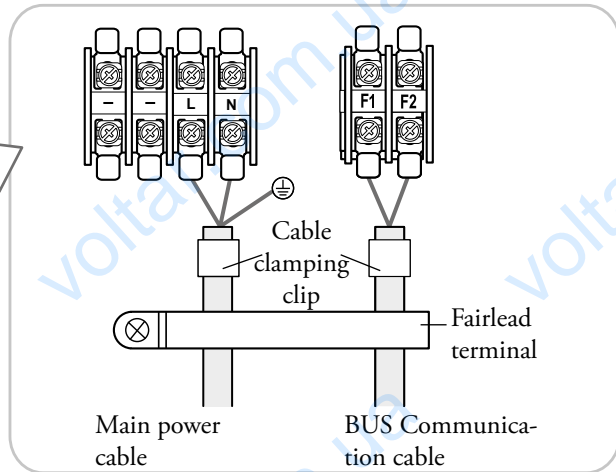

AUDAX PRO 5 - Supply voltage in mono-phase AC.

Electric power supply
M4 screw

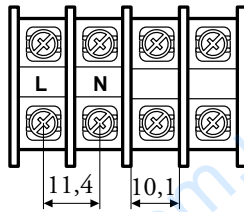

M4 screw communication BUS

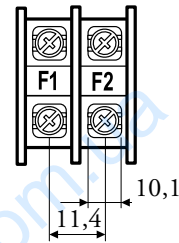

AUDAX PRO 8 and 10 - Supply voltage in mono-phase AC.

Electric power supply
M5 screw

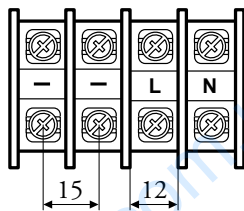

M3 screw communication BUS

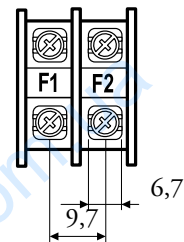

18 MAGIS COMBO / COMBO PLUS TERMINAL BLOCK ELECTRICAL CONNECTIONS

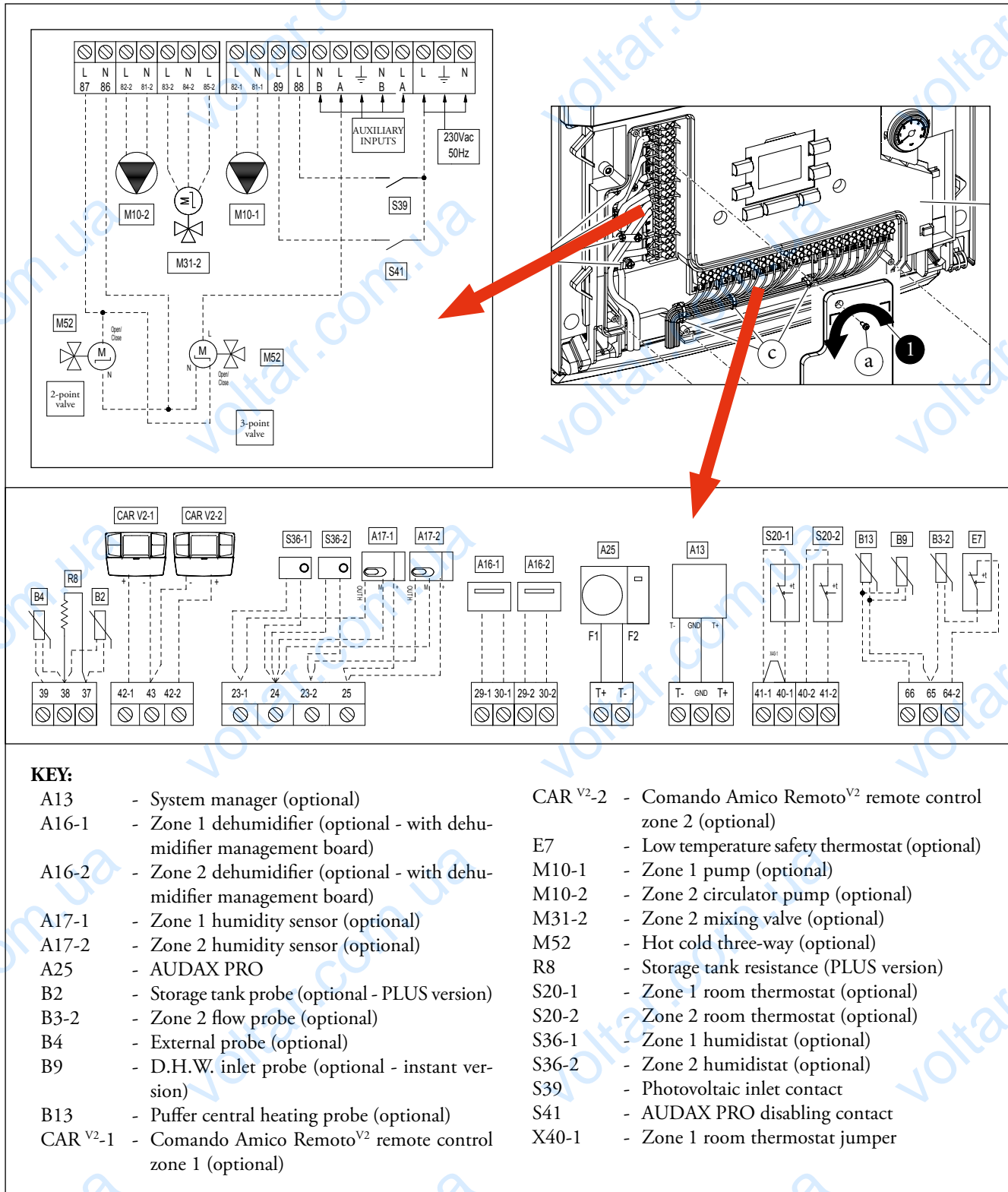

N.B.: To control the dehumidifiers, insert the 2 relay board kit code 3.026302 (optional) inside the MAGIS COMBO wall-hung indoor unit, for the respective dehumidifiers of the 2 zones. The relay board kit has only one contact for each zone and, therefore, allows the dehumidifier to work either in neutral air

or in cooled air.
For further information see the chapter on dehumidifiers.

MAGIS COMBO

19

MAGIS COMBO / MAGIS COMBO PLUS P.C.B.

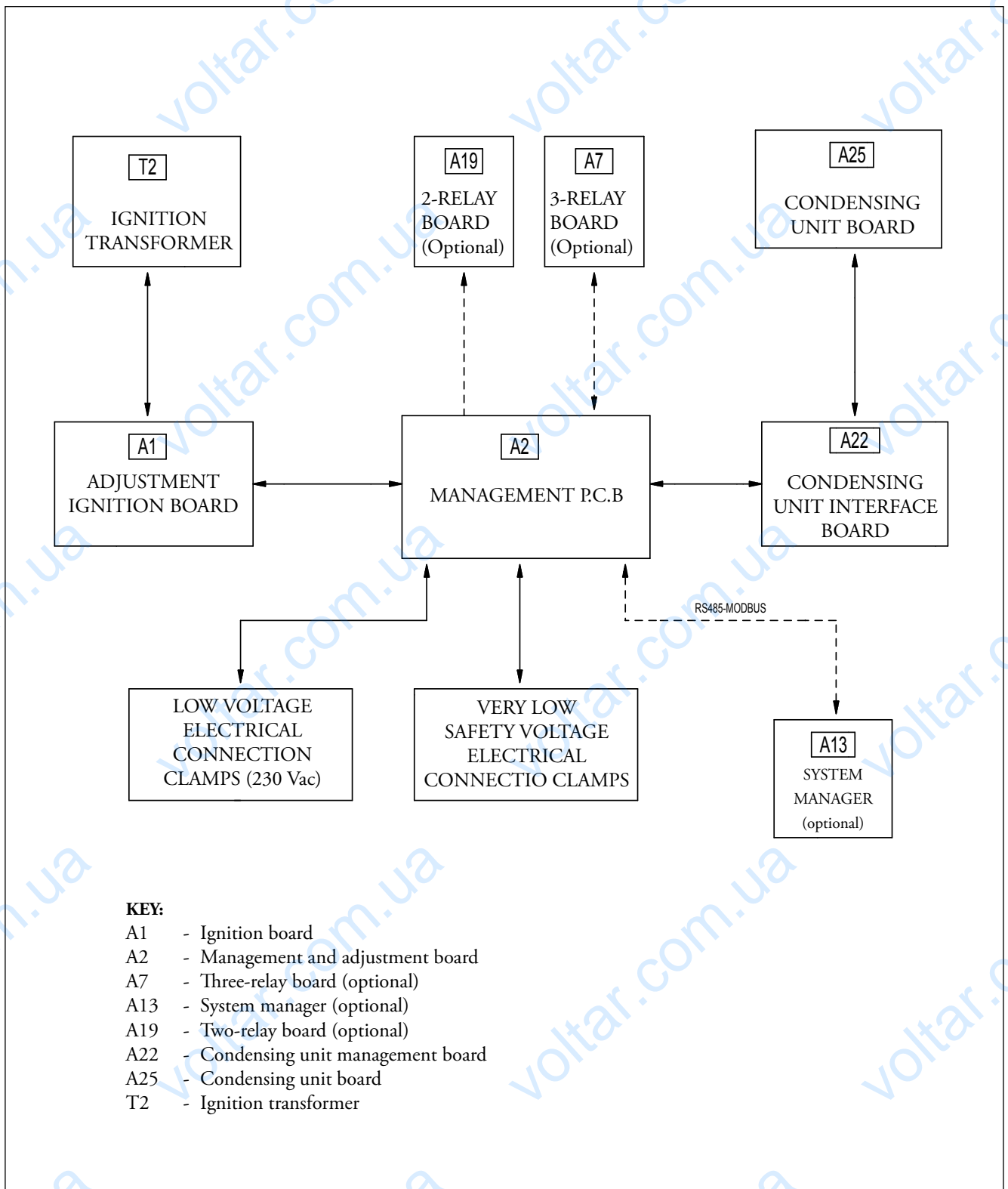

Instant version / PLUS version

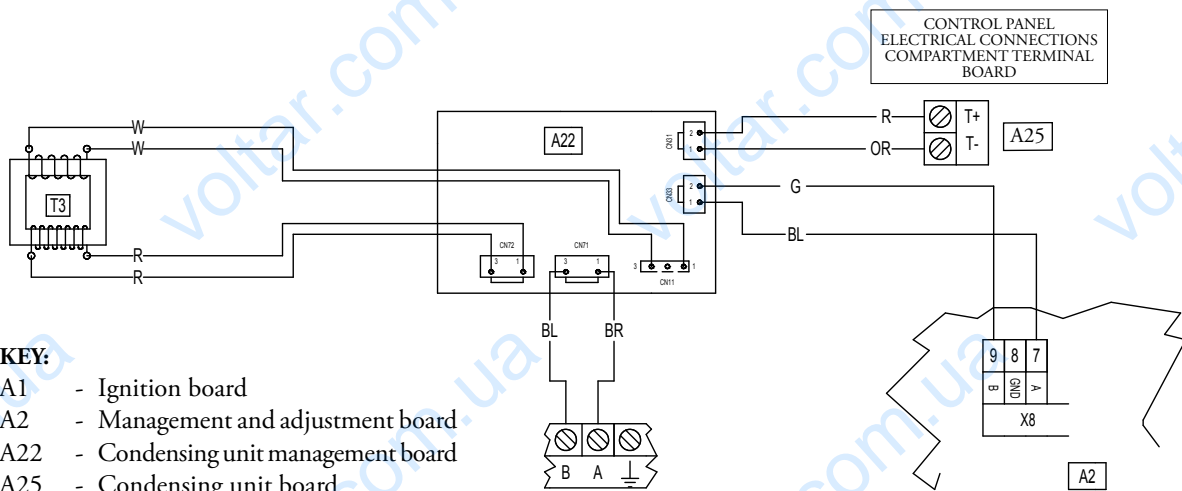
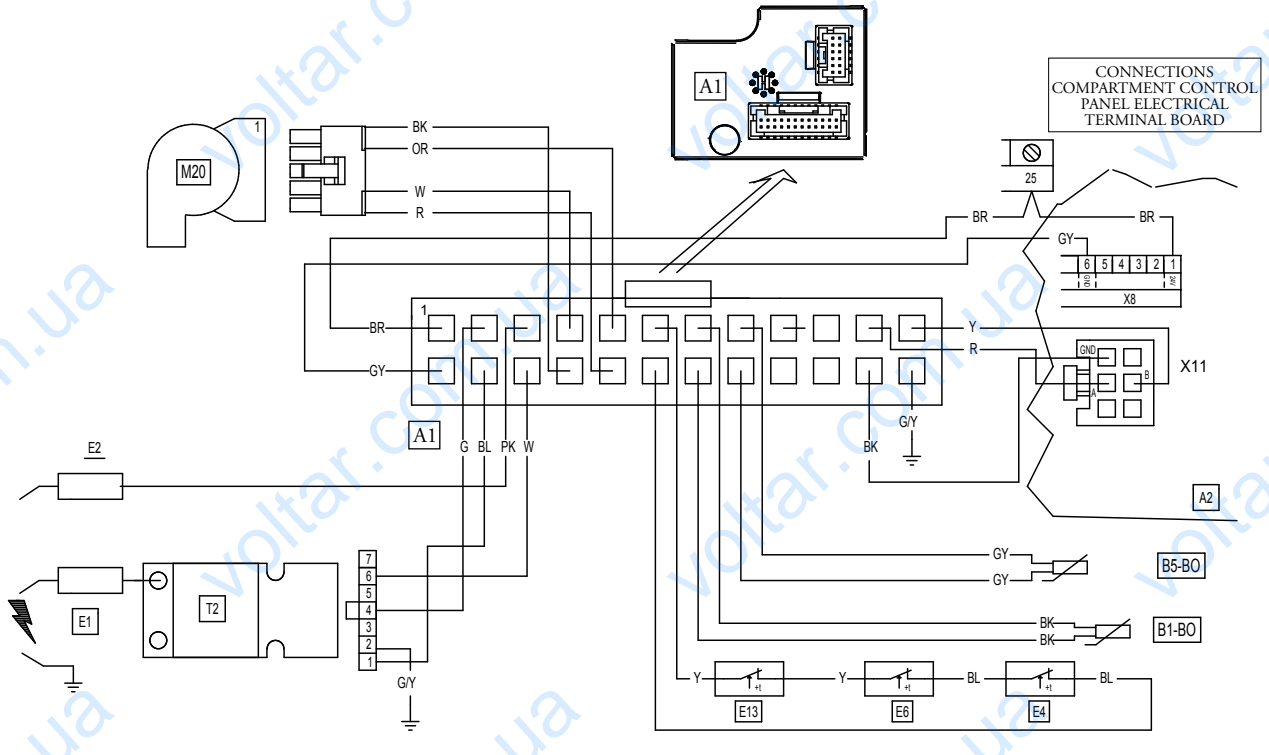

KEY:

- A1 - Ignition board
- A2 - Management and adjustment board
- A22 - Condensing unit management board
- A25 - Condensing unit board
- B1-BO - Heat unit flow probe
- B5-BO - Heat unit return probe
- E1 - Ignition electrode
- E2 - Detection electrode
- E4 - Safety thermostat
- E6 - Flue gas thermofuse
- E13 - Heat exchanger safety thermofuse
- M20 - Fan
- T2 - Ignition transformer
- T3 - Low voltage transformer

Colour code key:

- BK - Black
- BL - Blue

- BR - Brown
- G - Green
- DY - Grey
- OR - Orange
- P - Purple
- PK - Pink
- R - Red
- W - White
- Y - Yellow
- Y/G - Yellow/Green
- W/BK - White/Black

MAGIS COMBO

Instant version

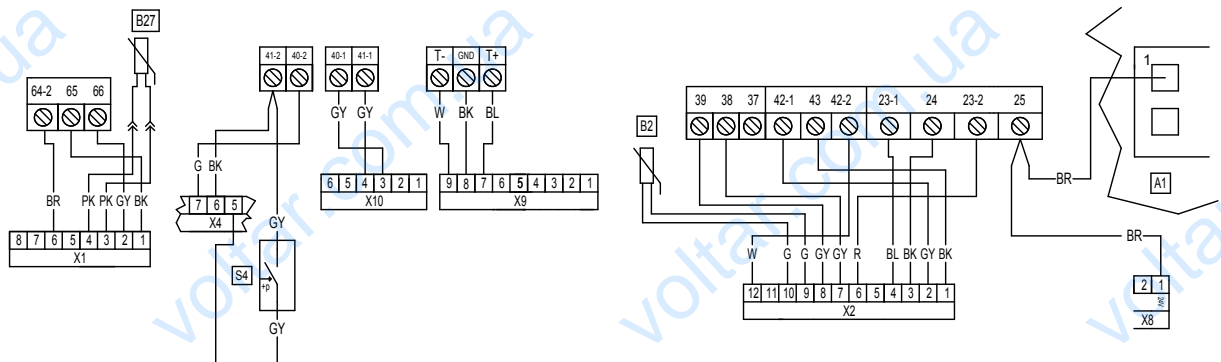
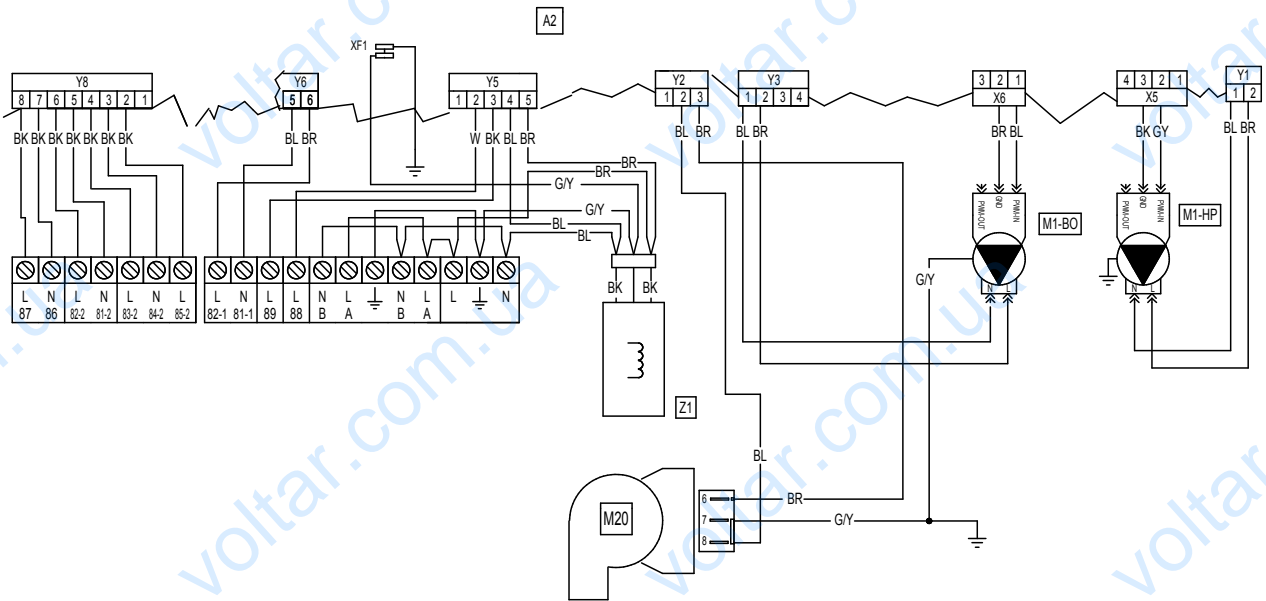

KEY:

- A1 - Ignition board
- A2 - Management and adjustment board
- B2 - D.H.W. probe
- B1-HP - Heat pump flow probe
- B5-HP - Heat pump return probe
- B25 - System flow-meter
- B27 - Liquid phase probe
- M1-BO - Heat generator circulator
- M1-HP - Heat pump circulator
- M20 - Fan
- M50-BO - Heat unit 3-way valve
- S4 - D.H.W. flow switch
- S5 - System pressure switch
- Z1 - Antijamming filter

Colour code key:

- | | | | |
|----|---------|------|----------------|
| BK | - Black | DY | - Grey |
| BL | - Blue | OR | - Orange |
| BR | - Brown | P | - Purple |
| G | - Green | PK | - Pink |
| | | R | - Red |
| | | W | - White |
| | | Y | - Yellow |
| | | Y/G | - Yellow/Green |
| | | W/BK | - White/Black |

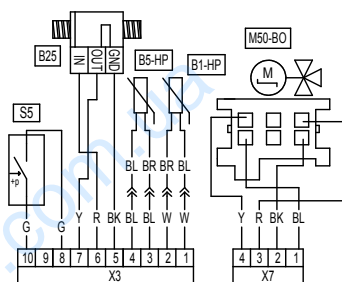

PLUS version

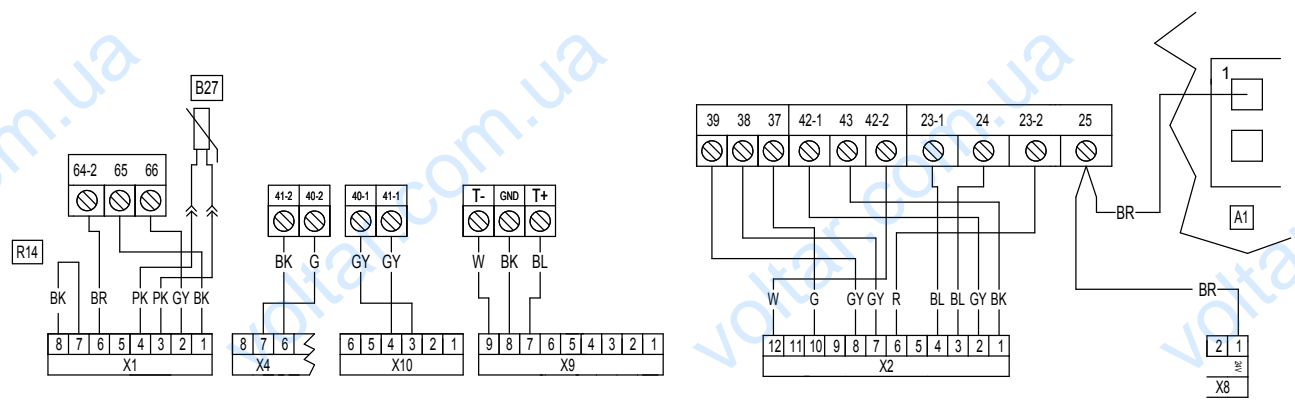
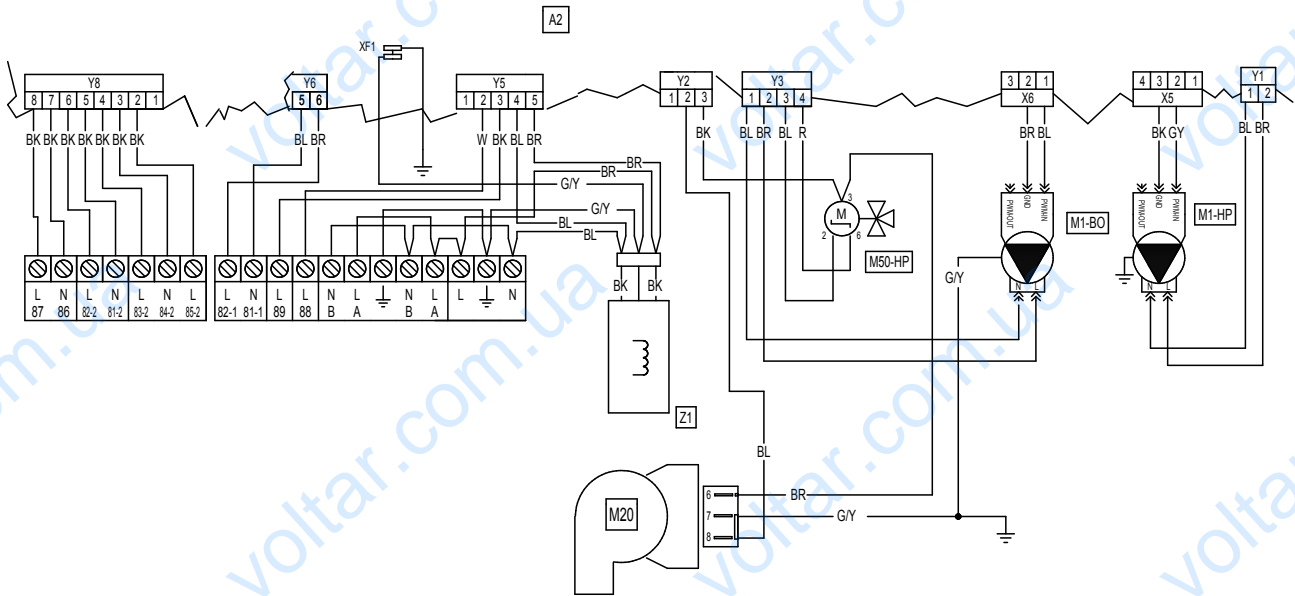

- KEY:**
- A1 - Ignition board
 - A2 - Management and adjustment board
 - B1-HP - Heat pump flow probe
 - B5-HP - Heat pump return probe
 - B25 - System flow-meter
 - B27 - Liquid phase probe
 - M1-BO - Heat generator circulator
 - M1-HP - Heat pump circulator
 - M20 - Fan
 - M50-BO - Heat unit 3-way valve
 - M50-HP - Heat pump 3-way valve
 - R14 - Configuration resistance
 - S5 - System pressure switch
 - Z1 - Antijamming filter

- Colour code key:**
- BK - Black
 - BL - Blue
 - BR - Brown

- G - Green
- DY - Grey
- OR - Orange
- P - Purple
- PK - Pink
- R - Red
- W - White
- Y - Yellow
- Y/G - Yellow/Green
- W/BK - White/Black

MAGIS COMBO

20

INSTALLING THE CHILLER LINES

The MAGIS COMBO cooling circuit uses the refrigerant R410A, therefore, it is necessary to take some measures for the proper operation of the machine:

- The R410A is a high pressure refrigerant, the pipes and other parts subject to pressure must be compliant and suitable for the refrigerant itself. Therefore, the pipes must be certified for cooling and it is necessary to observe the methods of installation stated on the instruction manual supplied with the product.
- Only use clean pipes with no harmful elements, oxides, dust, traces of iron or moisture.
- The foreign materials inside the pipes (including manufacturing oil) must be $\leq 30\text{mg}/10\text{ m}$.
- Only use equipment and fittings for R410A.
- The length of the pipes between the outdoor and indoor units and the difference must not exceed the specified limits. The maximum lengths of the chiller lines are listed below, based on the condensing unit model and the type of installation:

	AUDAX PRO 5	AUDAX PRO 8 and 10
A	$\leq 30\text{ m}$	$\leq 50\text{ m}$
H1	$\leq 20\text{ m}$	$\leq 30\text{ m}$
H2	$\leq 20\text{ m}$	$\leq 15\text{ m}$

NOTE: it is recommendable to provide for a siphon in the immediate vicinity of the outdoor condensing unit on the gas line pipe (pipe with larger diameter).

If the length of the chiller line is greater than the one given in the machine pre-load, it is recommendable to provide for a siphon halfway.

A siphon is also recommendable in the event of installation with drops between the outdoor condensing unit and indoor unit.

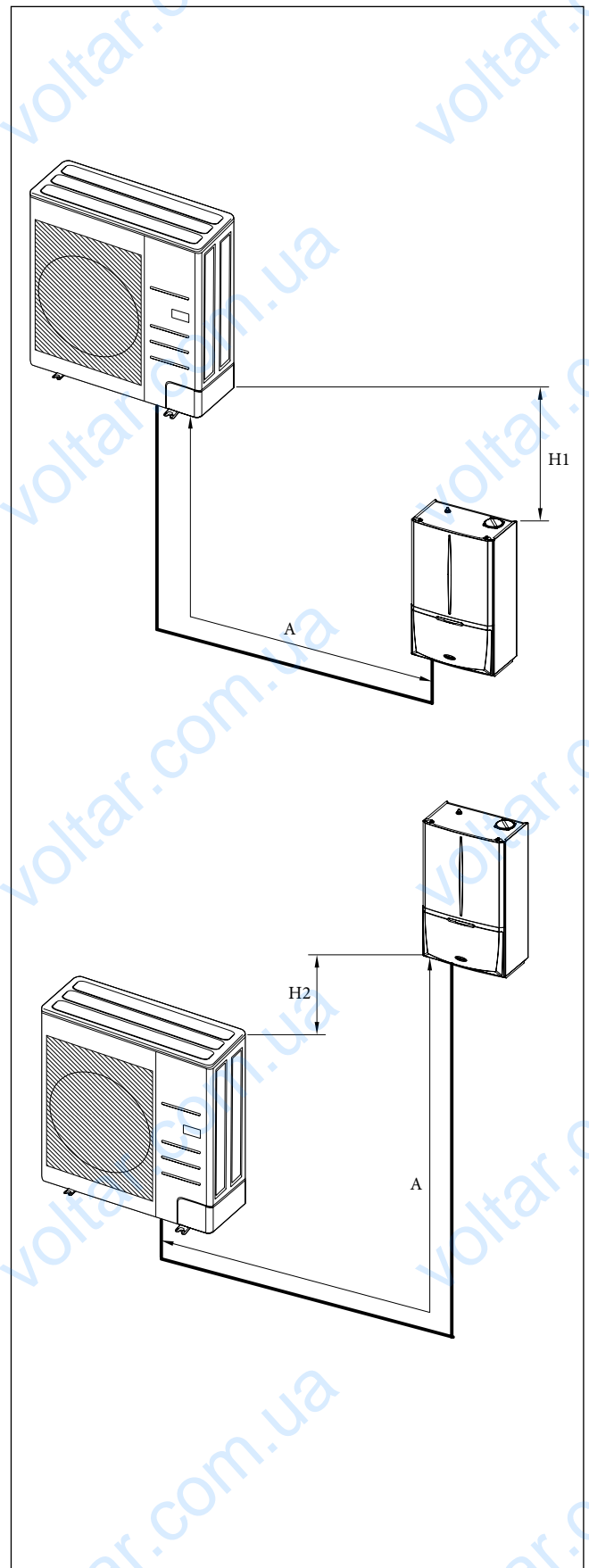

Selecting chiller line insulation.

- The gas and liquid chiller lines must be insulated with materials selected based on their respective diameters.
- Standard insulation is required at a temperature of 30°C with 85% relative humidity. Should the thermohygrometric conditions of the air be harsher, you must use insulations that can be selected from the table below.

NOTE: The insulation cannot be interrupted and for this reason, its junctions must be sealed with adhesive to prevent moisture from getting in.

Should the insulation be exposed to sunlight, it must be protected by wrapping it with electrical tape or material suitable for this type of application.

The insulation must be laid without its thickness being reduced in the bends and supports of the pipes.

Line	Pipe diameter (mm)	Insulation thickness		Notes
		Standard conditions (Less than 30 °C, RH 85%)	High humidity conditions (Over 30 °C, RH 85%)	
		EPDM, NBR		
Liquid	Ø 6.35 ÷ 19.05	9	9	The pre-selected material must be able to withstand temperatures exceeding 120°C.
	Ø 12.70 ÷ 19.05	13	13	
Gas	Ø 6.35	13	19	
	Ø 9.52	19	25	
	Ø 12.70			
	Ø 15.88			
Ø 19.05				

Topping up the coolant load.

Below is the default factory base load:

- AUDAX PRO 5 = 1.2 kg
- AUDAX PRO 8 and 10 = 2.0 kg

The top-up depends on the total length and diameter of the pipes. All the default factory loads are determined as follows, depending on the standard length of the pipes:

- AUDAX PRO 5 = ≤ 5m (liquid line pipe)

- AUDAX PRO 8 and 10 = ≤ 15m (liquid line pipe)

If the used pipes are longer than stated above, the load must be topped-up in the manner and quantities described in the instruction manual supplied with the product.

N.B.: To avoid breaking the compressor, do not top-up the coolant beyond the specified amount.

Model	Liquid line pipe external diameter (mm - inch)	Maximum length without base load top-up (liquid line pipe)	Top-up quantity for every additional metre of the liquid line pipe
AUDAX PRO 5	Ø 6.35 - 1/4"	≤ 5 m	20 g/m
AUDAX PRO 8/10	Ø 9.52 - 3/8"	≤ 15 m	50 g/m

MAGIS COMBO

21 MAGIS COMBO / MAGIS COMBO PLUS (HEAT PUMP) TECHNICAL DATA

		MAGIS COMBO 5	MAGIS COMBO 8	MAGIS COMBO 10
Central heating circuit				
Nominal power in CH mode with water set at 35 °C ⁽¹⁾	kW	5.80	7.71	9.70
Nominal power in CH mode with water set at 45 °C ⁽²⁾	kW	5.30	7.26	9.27
Nominal power in CH mode with water set at 55 °C ⁽³⁾	kW	4.80	6.17	8.45
CH mode nominal COP with water set at 35 °C ⁽¹⁾		4.53	4.08	4.09
CH mode nominal COP with water set at 45 °C ⁽²⁾		3.42	3.13	3.11
CH mode nominal COP with water set at 55 °C ⁽³⁾		2.64	2.34	2.35
Flow temperature range	°C	25 ÷ 55	25 ÷ 55	25 ÷ 55
Outdoor temp. limits for Heating mode operation	°C	- 20 ÷ 35	- 20 ÷ 35	- 20 ÷ 35
Cooling circuit				
Nominal power in cooling mode with water set at 18 °C ⁽¹⁾	kW	6.03	7.58	7.58
Nominal power in cooling mode with water set at 7 °C ⁽²⁾	kW	4.90	5.38	7.31
Cooling mode nominal EER with water set at 18 °C ⁽¹⁾		3.61	3.77	3.77
Cooling mode nominal EER with water set at 7 °C ⁽²⁾		2.62	2.41	2.38
Flow temperature range	°C	7 ÷ 25	7 ÷ 25	7 ÷ 25
Outdoor temp. limits for Cooling mode operation	°C	10 ÷ 46	10 ÷ 46	10 ÷ 46
Maximum absorbed power (Condensing unit + Indoor unit)	W	3200	4130	5200
Pump head available with 1000 l/h flow rate	kPa (m H ₂ O)	48.78 (5.0)	48.78 (5.0)	48.78 (5.0)
Cooling circuit circulator power absorption	W	52	52	52
AUDAX PRO condensing unit general data				
C.H. sound power level	dB(A)	62	66	66
Electric power supply	V/Hz	230/50	230/50	230/50
Permitted voltage range	V	198 ÷ 264	198 ÷ 264	198 ÷ 264
Maximum absorbed current in normal operation	A	20	22	22
Fuse required	A	30	40	40
Refrigerant fluid load (R410A)	g	1200	2000	2000
Weight (net / gross)	kg	47.5 / 52.5	74.0 / 82.0	74.0 / 82.0

THE REPORTED DATA REFERS TO THE FOLLOWING CONDITIONS (in compliance with EN 14511):

ROOM	HEATING PHASE (°C)	COOLING PHASE (°C)
Water TEMP. (F/R) ⁽¹⁾ - AIR (db/wb)	35/30 - 7/6	18/23 - 35 (bs)
Water TEMP. (F/R) ⁽²⁾ - AIR (db/wb)	45/40 - 7/6	7/12 - 35 (bs)
Water TEMP. (F/R) ⁽³⁾ - AIR (db/wb)	55/47 - 7/6	

Domestic hot water maximum heating power		kW (kcal/h)	28.1 (24,204)
Central heating maximum heat input		kW (kcal/h)	24.9 (21,452)
DHW maximum useful heat output		kW (kcal/h)	27.3 (23,478)
CH maximum useful heat output		kW (kcal/h)	24.0 (20,640)
Minimum nominal heat input		kW (kcal/h)	5.1 (4,382)
Minimum nominal heat output		kW (kcal/h)	4.8 (4,128)
Efficiency at 100% P _n (80/60°C)		%	96.2
Efficiency at 30% of the load (80/60°C)		%	98.4
Efficiency at 100% P _n (50/30°C)		%	104.6
Efficiency at 30% of the load (50/30°C)		%	106.1
Efficiency at 100% P _n (40/30°C)		%	106.8
Efficiency at 30% of the load (40/30°C)		%	106.1
Central heating circuit			
Adjustable central heating temperature (min. / max)		°C	20 ÷ 80
System max. working temperature		°C	90
System max. working pressure		bar	3
System expansion vessel nominal/(real) capacity		litres	10.0 / (8.3)
System expansion vessel factory-set pressure		bar	1.0
Head available with 1000 l/h flow rate		kPa (m H ₂ O)	26.91 (2.7)
DHW circuit			
Hot water production useful heat output		kW (kcal/h)	27.3 (23,478)
DHW adjustable temperature		°C	30 ÷ 60
DHW circuit max. pressure		bar	10
Domestic hot water circuit min. dynamic pressure		bar	0.3 (Instant version)
D.H.W. min. withdrawal		litres/min	1.5 (Instant version)
Flow rate in continuous service (ΔT 30°C)		litres/min	13.1 (Instant version)
Gas supply			
Gas flow rate at METHANE burner (G20)	MIN - MAX	m ³ /h	0.54 ÷ 2.64 (2.98 D.H.W.)
Gas flow rate at LPG burner (G30)	MIN - MAX	kg/h	0.40 ÷ 1.97 (2.22 D.H.W.)
Gas flow rate at LPG burner (G31)	MIN - MAX	kg/h	0.40 ÷ 1.94 (2.19 D.H.W.)
Electric power supply		V/Hz	230/50
Nominal power absorption		A	1.0
Installed electric power		W	125
Fan power absorbed power		W	80
Power absorbed by the indoor unit pump		W	60
Power absorbed by the indoor unit in stand-by		W	10
Electric insulation rating	IP		X4D
Appliance water content		litres	2.8
Weight of empty generator		kg	55.8
Useful efficiency at 100% output (Italian Lgs. D. 192/05 as amended)			>93+2·log P _n (P _n = 24.0 kW)

MAGIS COMBO

23

MAGIS COMBO (HEAT GENERATOR) COMBUSTION FEATURES

		Methane (G20)	LPG (G30)	LPG (G31)
Combustion efficiency 100% Pn (80/60°C)	%	97.4	97.4	97.4
Combustion efficiency P min (80/60°C)	%	97.8	97.8	97.8
Effective efficiency at 100% Pn (80/60°C)	%	96.2	96.2	96.2
Effective efficiency P min (80/60°C)	%	94.2	94.2	94.2
Effective efficiency at 100% Pn (50/30°C)	%	104.6	104.6	104.6
Effective efficiency P min (50/30°C)	%	104.5	104.5	104.5
Effective efficiency at 100% Pn (40/30°C)	%	106.8	106.8	106.8
Effective efficiency P min (40/30°C)	%	106.3	106.3	106.3
Chimney losses with burner on (100% Pn) (80/60°C)	%	2.8	2.8	2.8
Chimney losses with burner on (P min) (80/60°C)	%	2.2	2.2	2.2
Chimney losses with burner off	%	0.01	0.01	0.01
Casing losses with burner on (100% Pn) (80/60°C)	%	0.2	0.2	0.2
Casing losses with burner on (P min) (80/60°C)	%	3.6	3.6	3.6
Casing losses with burner off	%	0.44	0.44	0.44
Flue temperature Maximum Heat Input	°C	70	76	70
Flue temperature Minimum Heat Input	°C	57	63	59
Flue flow rate at Central Heating Maximum Heat Input	kg/h	38	35	40
Flue flow rate at Maximum Domestic Hot Water Heat Input	kg/h	44	40	45
Flue flow rate at Minimum Heat Input	kg/h	9	8	9
CO ₂ at the Maximum Central Heating Heat Input	%	9.70	12.30	10.70
CO ₂ at the Maximum Domestic Hot Water Heat Input	%	9.60	12.30	10.60
CO ₂ at the Minimum Heat Input	%	8.60	11.30	10.00
CO at Maximum Heat Input	mg/kWh	267	721	234
CO at Minimum Heat Input	mg/kWh	7	10	6
NO _x at the Maximum Heat Input	mg/kWh	52	137	40
NO _x at the Minimum Heat Input	mg/kWh	17	38	21
Weighted CO	mg/kWh	20	-	-
Weighted NO _x	mg/kWh	29	-	-
NO _x class	-	6	6	6
Head available at fan (Min. - Max.)	Pa	30 - 172		

NOTE: The condensation heat generator can also work with propane air.

Gas flow rates refer to the NHV at the temperature of 15° C and pressure of 1013 mbar.

Flue temperature values refer to an air inlet temperature of 15°C and flow/return temperature = 80/60°C.

MAGIS COMBO 5 / MAGIS COMBO 5 PLUS

Low temperature (30/35)

Parameter	Value	Colder zones	Average zones	Hotter zones
Annual energy consumption for the heating function (Q_{HE})	kWh/year	5871	2894	1566
Room central heating seasonal efficiency (η_s)	η_s %	128	154	202
Nominal heat output	kW	7.80	5.50	6.00

Average temperature (47/55)

Parameter	Value	Colder zones	Average zones	Hotter zones
Annual energy consumption for the heating function (Q_{HE})	kWh/year	8102	4438	2127
Room central heating seasonal efficiency (η_s)	η_s %	91	112	133
Nominal heat output	kW	7.70	6.20	5.40

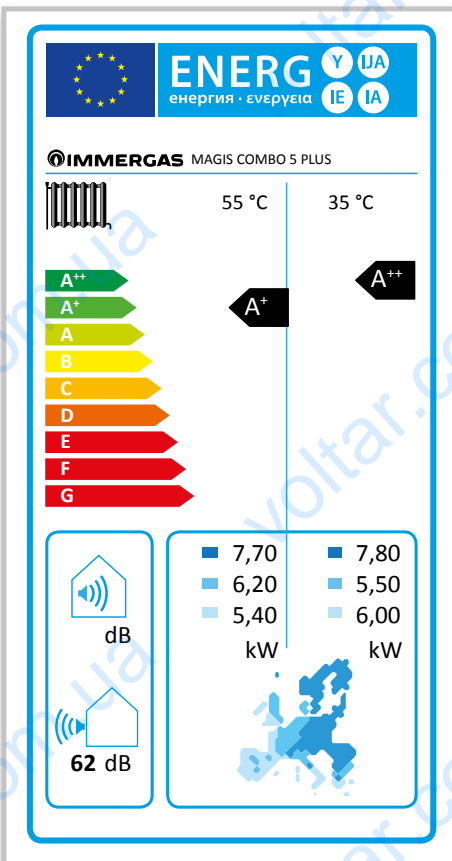
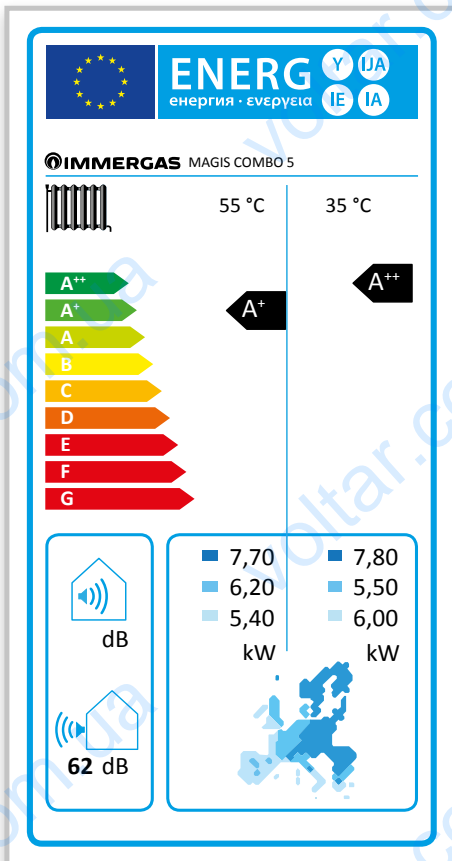

MAGIS COMBO 5

25 "POWER" AND "COP" CENTRAL HEATING MAGIS COMBO 5 - MAGIS COMBO 5 PLUS

- Correction factor stated DC = 0.99
- TOL = -20 °C

Temperature air °C		Output (kW) Nom. / Max.	COP (EN 14511) Nom. / Max.
d.b.	(w.b.)	Water flow temperature 35 °C	
12	(11)	6.14	4.67
7	(6)	5.80	4.53
2	(1)	4.60	3.31
-7	(-8)	5.10	2.49
-15	(-16)	4.50	2.14
-20	(-21)	4.13	1.97
d.b.	(w.b.)	Water flow temperature 45 °C	
12	(11)	5.69	3.58
7	(6)	5.30	3.42
2	(1)	4.40	2.59
-7	(-8)	4.90	1.99
-15	(-16)	4.10	1.62
-20	(-21)	--	--
d.b.	(w.b.)	Water flow temperature 55 °C	
12	(11)	5.22	2.81
7	(6)	4.80	2.64
2	(1)	4.20	2.09
-7	(-8)	4.70	1.63
-15	(-16)	--	--
-20	(-21)	--	--

25.1 "POWER" AND "EER" COOLING MAGIS COMBO 5 - MAGIS COMBO 5 PLUS

Temperature air °C	Output (kW) Nom.	Output (kW) Max.	EER (EN 14511) Nom.	EER (EN 14511) Max.
d.b.	Water flow temperature 18 °C			
35	6.03	6.67	3.61	3.39
d.b.	Water flow temperature 7 °C			
35	4.90	4.90	2.62	2.62

MAGIS COMBO 8 / MAGIS COMBO 8 PLUS

Low temperature (30/35)

Parameter	Value	Colder zones	Average zones	Hotter zones
Annual energy consumption for the heating function (Q_{HE})	kWh/year	3884	3061	1435
Room central heating seasonal efficiency (η_s)	η_s %	127	151	202
Nominal heat output	kW	5.10	5.70	5.50

Average temperature (47/55)

Parameter	Value	Colder zones	Average zones	Hotter zones
Annual energy consumption for the heating function (Q_{HE})	kWh/year	11504	5472	2890
Room central heating seasonal efficiency (η_s)	η_s %	92	103	125
Nominal heat output	kW	11.10	7.00	6.90

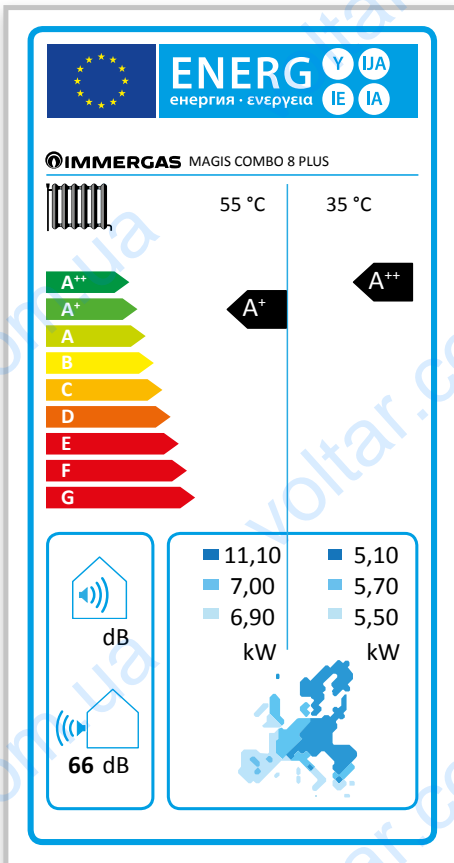
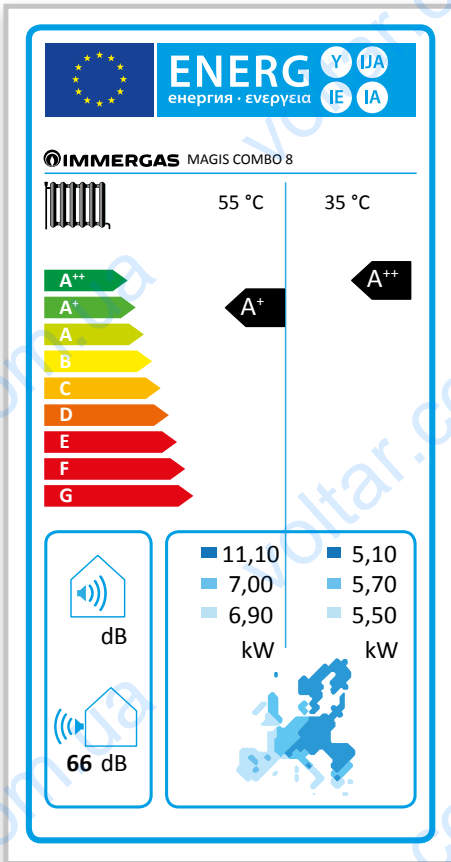

MAGIS COMBO 8

27 "POWER" AND "COP" CENTRAL HEATING MAGIS COMBO 8 - MAGIS COMBO 8 PLUS

- Correction factor stated DC = 1.00
- TOL = -20 °C

Temperature air °C		Output (kW) Nom. / Max.	COP (EN 14511) Nom. / Max.
d.b.	(w.b.)	Water flow temperature 35 °C	
12	(11)	8.63	4.61
7	(6)	7.71	4.08
2	(1)	6.46	3.20
-7	(-8)	8.53	2.71
-15	(-16)	5.20	1.81
-20	(-21)	--	--
d.b.	(w.b.)	Water flow temperature 45 °C	
12	(11)	8.01	3.51
7	(6)	7.26	3.13
2	(1)	6.07	2.52
-7	(-8)	8.00	2.18
-15	(-16)	3.21	0.96
-20	(-21)	--	--
d.b.	(w.b.)	Water flow temperature 55 °C	
12	(11)	7.34	2.66
7	(6)	6.17	2.34
2	(1)	4.90	1.54
-7	(-8)	4.66	1.13
-15	(-16)	--	--
-20	(-21)	--	--

27.1 "POWER" AND "EER" COOLING MAGIS COMBO 8 - MAGIS COMBO 8 PLUS

Temperature air °C	Output (kW) Nom.	Output (kW) Max.	EER (EN 14511) Nom.	EER (EN 14511) Max.
d.b.	Water flow temperature 18 °C			
35	7.58	8.41	3.77	3.59
d.b.	Water flow temperature 7 °C			
35	5.38	5.38	2.41	2.41

MAGIS COMBO 10 / MAGIS COMBO 10 PLUS

Low temperature (30/35)

Parameter	Value	Colder zones	Average zones	Hotter zones
Annual energy consumption for the heating function (Q_{HE})	kWh/year	6981	5119	2380
Room central heating seasonal efficiency (η_s)	η_s %	124	150	195
Nominal heat output	kW	9.00	9.50	8.80

Average temperature (47/55)

Parameter	Value	Colder zones	Average zones	Hotter zones
Annual energy consumption for the heating function (Q_{HE})	kWh/year	10911	7217	3773
Room central heating seasonal efficiency (η_s)	η_s %	87	104	125
Nominal heat output	kW	10.00	9.30	9.00

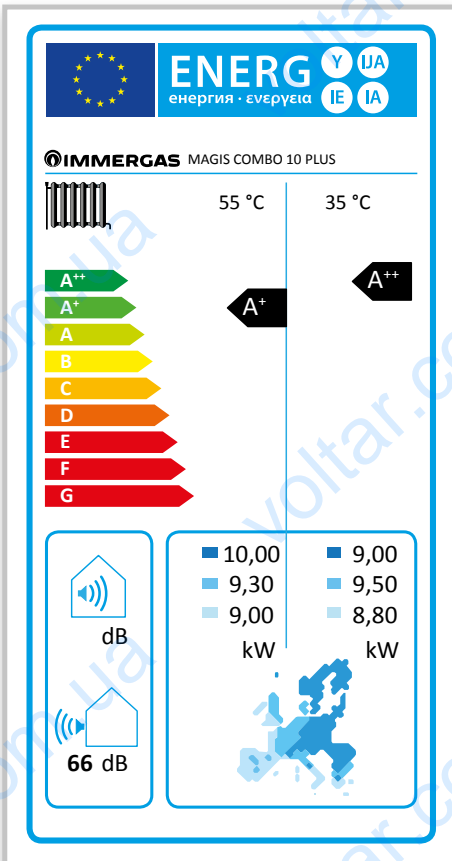
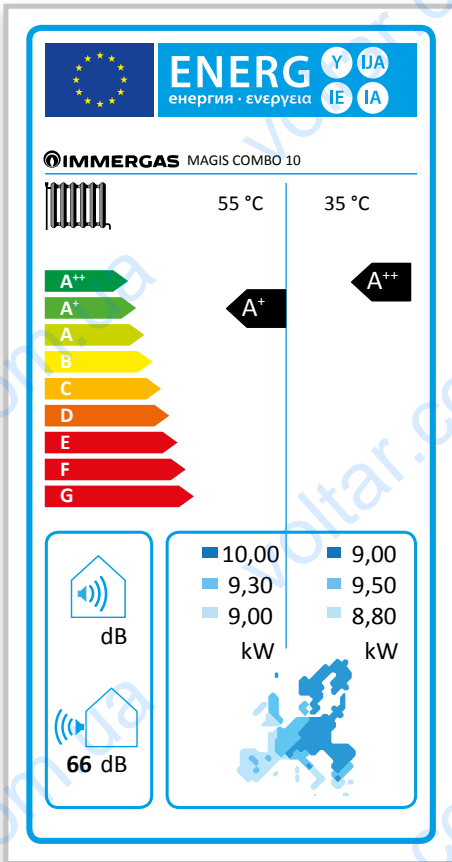

MAGIS COMBO 10

29 "POWER" AND "COP" CENTRAL HEATING MAGIS COMBO 10 - MAGIS COMBO 10 PLUS

- Correction factor stated DC = 1.00
- TOL = -20 °C

Temperature air °C		Output (kW) Nom	Output (kW) Max.	COP (EN 14511) Nom	COP (EN 14511) Max.
d.b.	(w.b.)	Water flow temperature 35 °C			
12	(11)	11.22	11.22	4.05	4.05
7	(6)	9.70	9.80	4.09	4.10
2	(1)	8.38	8.38	3.01	3.01
-7	(-8)	8.53	8.61	2.71	2.50
-15	(-16)	7.26	7.26	2.18	2.18
-20	(-21)	6.42	6.42	1.88	1.88
d.b.	(w.b.)	Water flow temperature 45 °C			
12	(11)	10.07	10.07	4.05	4.05
7	(6)	9.27	9.27	3.11	3.11
2	(1)	8.47	8.47	2.39	2.39
-7	(-8)	8.04	8.04	2.02	2.02
-15	(-16)	5.77	5.77	1.83	1.83
-20	(-21)	--	--	--	--
d.b.	(w.b.)	Water flow temperature 55 °C			
12	(11)	9.82	9.82	2.14	2.14
7	(6)	8.45	8.45	2.35	2.35
2	(1)	6.56	6.56	1.54	1.54
-7	(-8)	5.05	5.05	1.11	1.11
-15	(-16)	--	--	--	--
-20	(-21)	--	--	--	--

29.1 "POWER" AND "EER" COOLING MAGIS COMBO 10 - MAGIS COMBO 10 PLUS

Air temperature °C	Output (kW) Nom.	Output (kW) Max.	EER (EN 14511) Nom.	EER (EN 14511) Max.
d.b.	Water flow temperature 18 °C			
35	7.58	10.22	3.77	3.24
d.b.	Water flow temperature 7 °C			
35	7.31	7.31	2.38	2.38

30 KIT 2 ZONES FOR COUPLING MAGIS COMBO (CODE 3.026301)



The 2 zone kit for coupling with MAGIS COMBO is composed of a frame, open hydraulic manifold, low electric consumption solenoid valves, three-way mixing valve, hydraulic fitting and pipes and thermometers for temperature reading.

The pumps included in the kit are distinguished for being very elastic, also thanks to the 7 operating curves that can be pre-set. All components are already assembled and ready to operate. All electrical connections are to be taken to the MAGIS COMBO P.C.B.

This kit is to be used to control differential temperature systems and/or divided into two distinct zones.

With the acquisition of the outdoor temperature, the MAGIS COMBO electronics enables you to select independent flow temperature curves for each of the 2 zones of the system (both with C.H. and cooling).

Inserting these kits into the system enhances overall comfort and energy savings.

30.1 DIMENSIONS AND CONNECTIONS

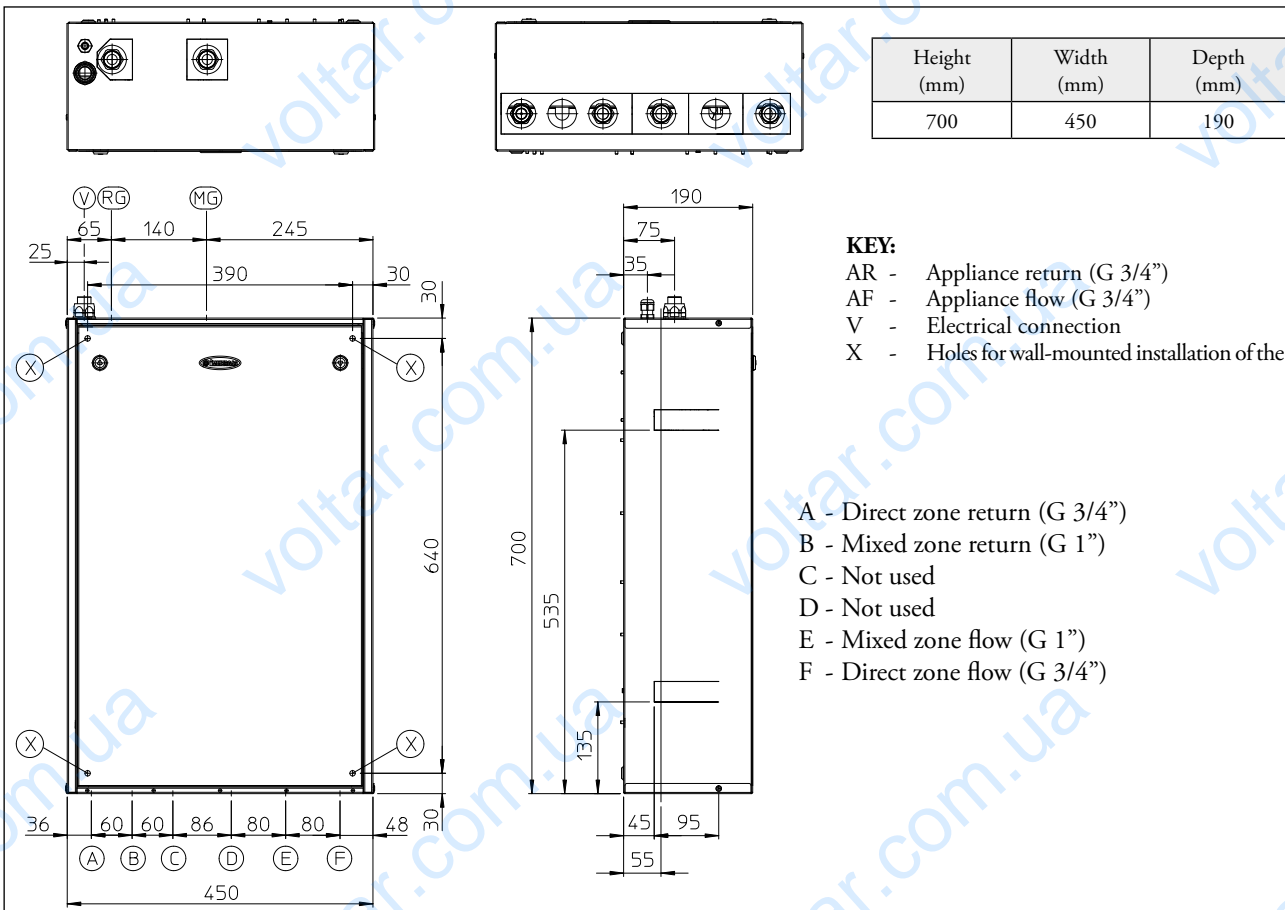

MAGIS COMBO

30.2

MAIN COMPONENTS KIT 2 ZONES FOR COUPLING MAGIS COMBO

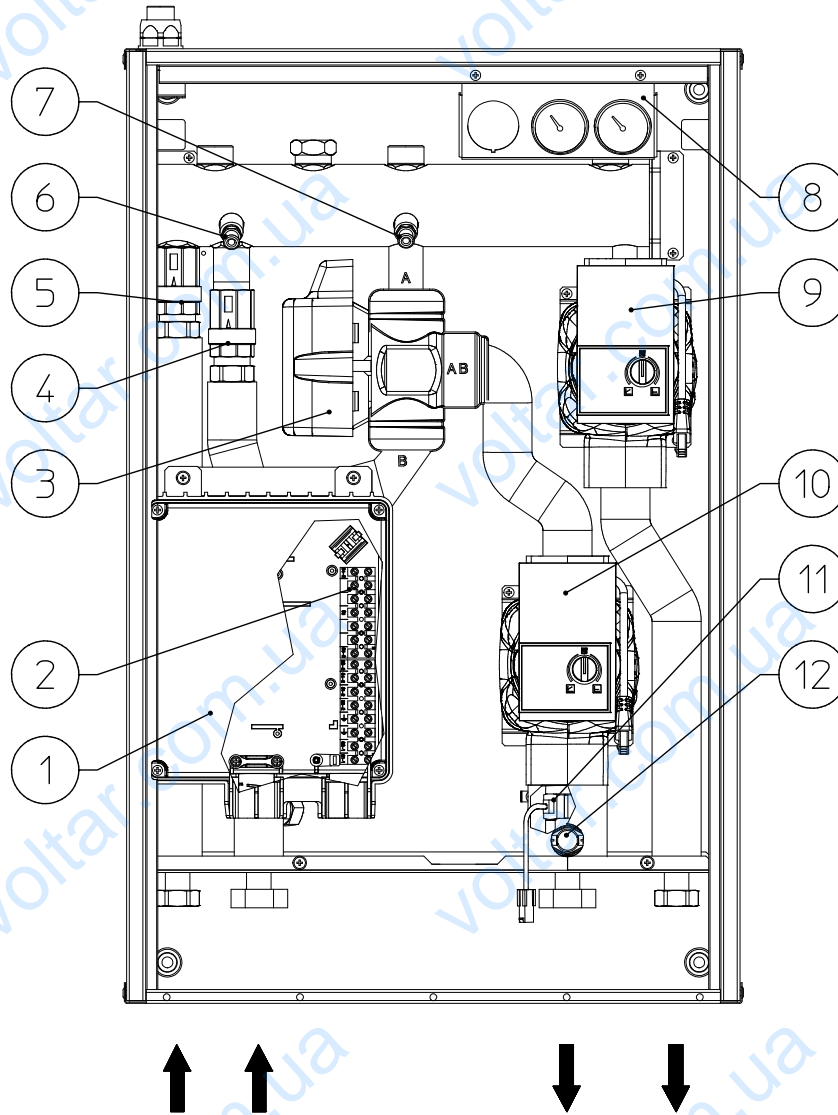

KEY:

- 1 - Connections box
- 2 - Connections terminal board
- 3 - Mixing valve
- 4 - Mixed zone return circuit "Europa type" one-way valve
- 5 - Direct zone return circuit "Europa type" one-way valve
- 6 - Drain fitting
- 7 - Drain fitting
- 8 - Flow temperature thermometers
- 9 - Direct zone pump
- 10 - Mixed zone pump
- 11 - Mixed zone flow probe
- 12 - Safety thermostat mixed zone

30.3

WIRING DIAGRAM KIT 2 ZONES FOR COUPLING MAGIS COMBO

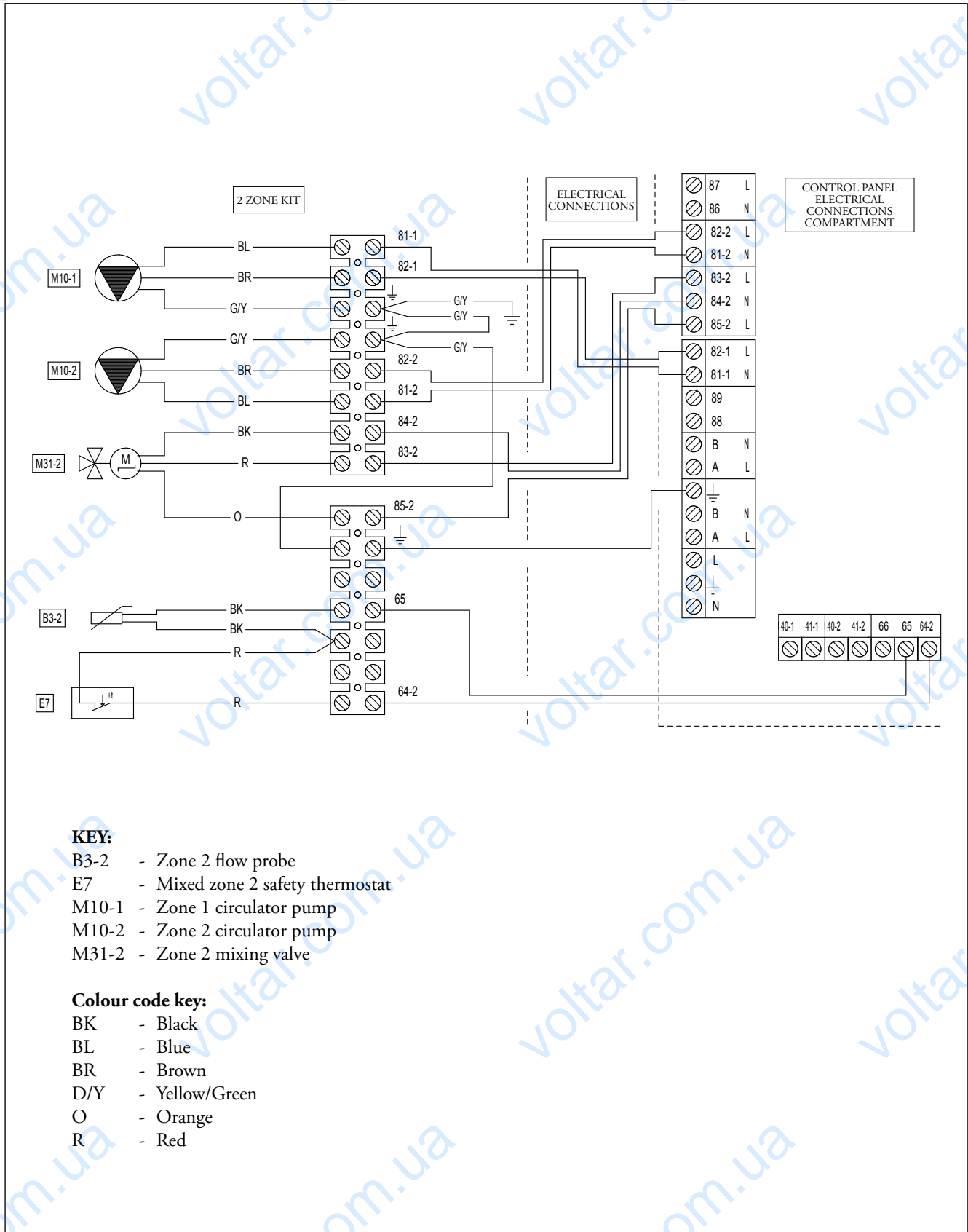

MAGIS COMBO

30.4 TECHNICAL DATA KIT 2 ZONES FOR COUPLING MAGIS COMBO

		2 zones kit for MAGIS COMBO
Maximum nominal pressure	bar	3
Water content in device	litres	1.5
Total head available in non-mixed zone with 1000 l/h flow rate (max.)	kPa (m H ₂ O)	49.4 (5.00)
Total head available in mixed zone (mixing valve open) with 1000 l/h flow rate (max.)	kPa (m H ₂ O)	46.8 (4.80)
Empty device weight	kg	21.1
Full device weight	kg	22.6
Electrical connection	V/Hz	230/50
Maximum input	A	0.7
Installed electric power	W	135
EEI value	-	≤ 0.20 - Part. 3
Electric plant protection	-	IPX4D
Hydraulic side generator - kit maximum distance	m	15

30.5 CIRCULATION PUMP SETTINGS AND CONFIGURATIONS

The kits are supplied with circulating pumps fitted with speed regulator. These settings are suitable for most systems.

For proper operation one must select the most suitable type of operation for the system and select a speed between 1 and 7.

- **Program constant head (ΔP C).** The circulator pump maintains the pressure level (head) constant as the system heat demand decreases (flow rate reduction). With these settings, the circulator pump is suitable for all floor systems where all the circuits must be balanced for the same drop in head. One can select the operating level from minimum to maximum by turning the selector switch clockwise in the relative power scale (refer to the drawing below).

- **Program proportional head (ΔP V).** This allows the pressure level (head) to be proportionally reduced as the system heat demand decreases (flow rate reduction). Thanks to this function, the electric power consumption of the circulator pump is reduced further: the energy (power) used by the pump decreases according to the pressure level and flow rate. With this setting, the pump guarantees optimal performance in most heating systems, proving particularly suitable in single-pipe and two-pipe installations. Any noise originating from the water flow in the pipes, valves and radiators is eliminated by reducing the head. One can select the operating level from minimum to maximum by turning the selector switch anticlockwise on the relative power scale (refer to the drawing below).

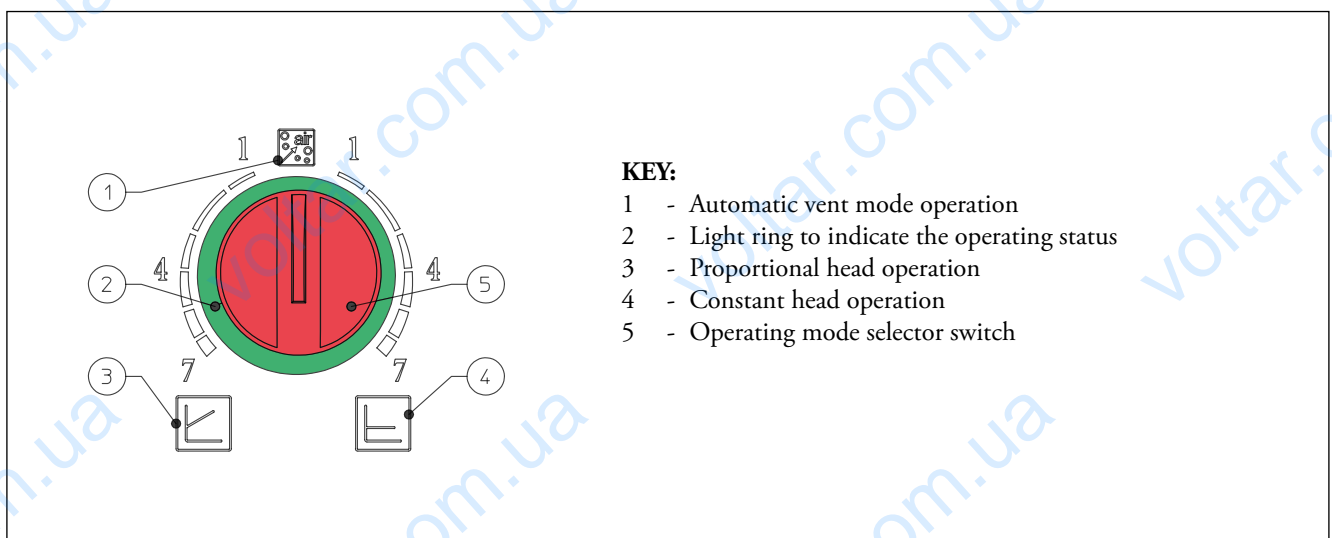

30.6

GRAPHICS PUMPS WITH CONSTANT HEAD PROGRAM

The kit contains an electronic low consumption circulation pump, whose flow rate/head features are shown in the graph below.

All pumps in the kit are suitable for operation with heat and cold carrying fluid.

WILO YONOS PARA RS 15-7 RKA CM 130

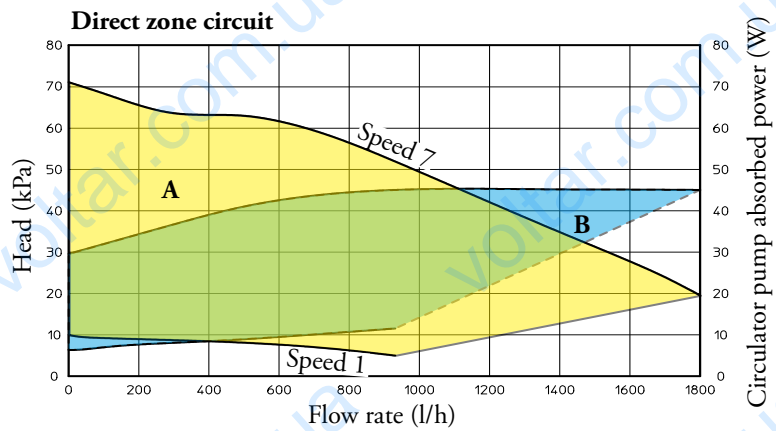
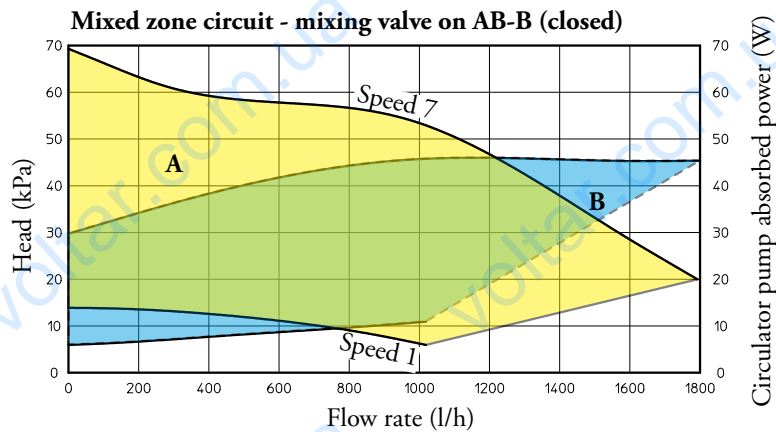
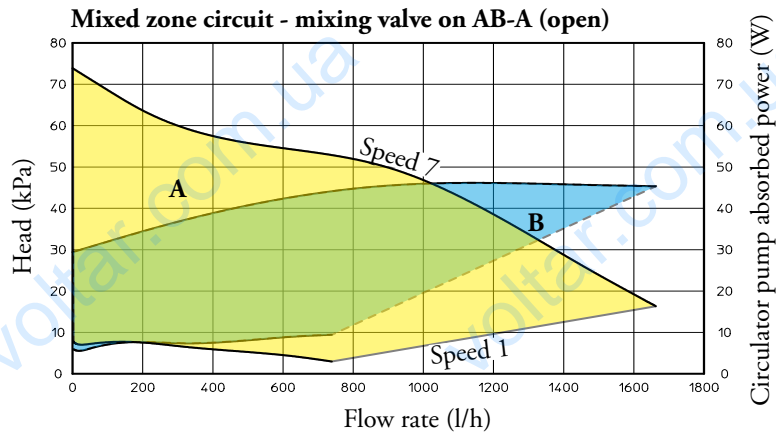

KEY:

A = Head available at speed 1 ÷ 7

B = Power absorbed by the system pump (dotted area)

EEl ≤ 0.20

MAGIS COMBO

30.7

GRAPHICS PUMPS WITH PROPORTIONAL HEAD PROGRAM

The kit contains an electronic low consumption circulation pump, whose flow rate/head features are shown in the graph below.

All pumps in the kit are suitable for operation with heat and cold carrying fluid.

WILO YONOS PARA RS 15-7 RKA CM 130

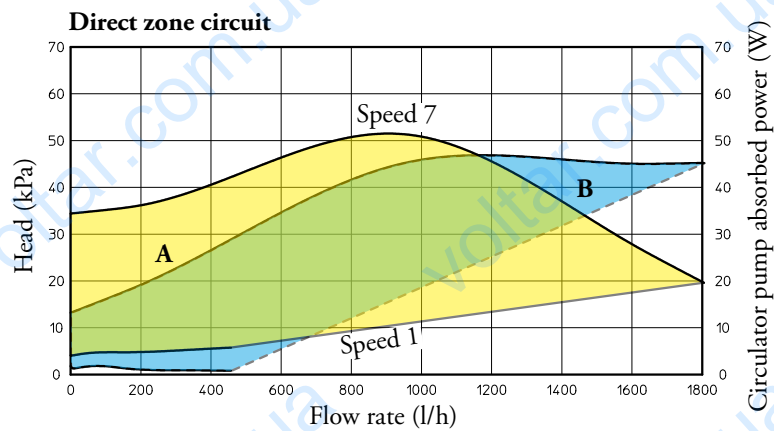
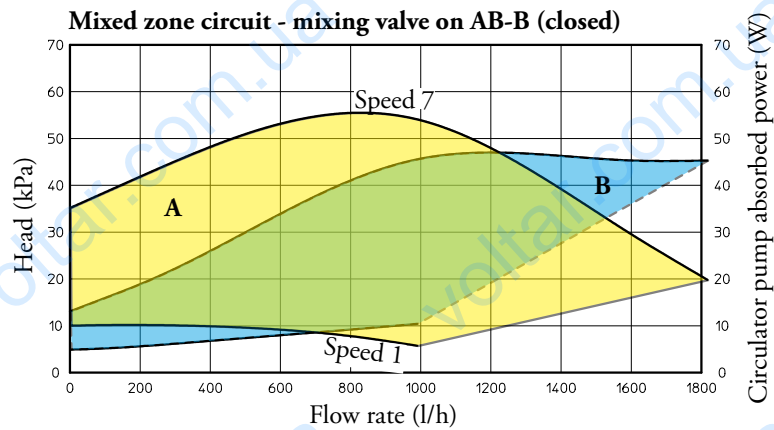
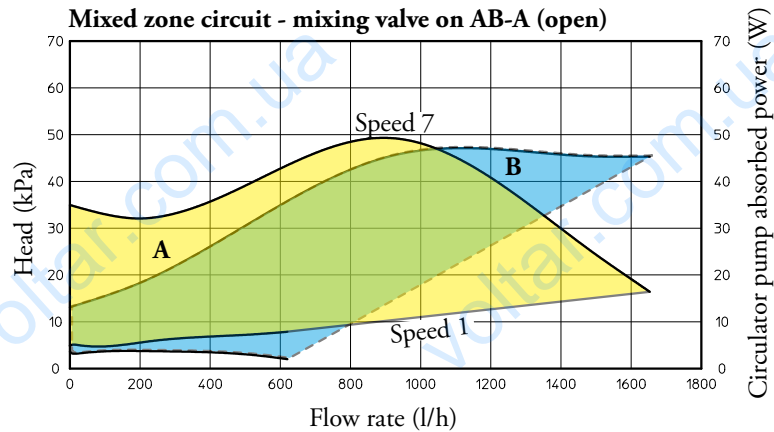

KEY:

A = Head available at speed 1 + 7

B = Power absorbed by the system pump (dotted area)

EEI ≤ 0.20

31

SYSTEM MANAGER



The System manager (optional) is able to expand the number of zones that can be controlled by MAGIC COMBO (more than 2 zones) and control up to three dehumidifiers.

Designed to enhance climatic comfort, it allows you to set different climatic curves for each zone, both for hot and cold. The user interface is made up from an LCD with matrix and a 6-key membrane keyboard. Installation takes place on a guide for electric components from control board.

Allows controlling, coupled with dedicated expansions, auxiliaries such as: circulation pump, mixing valve, dehumidifier, recirculation pump, 3-way diverter valve for cooling/heating.

31.1

TECHNICAL FEATURES

Using the system manager (integrated with the relative expansion kits) it is possible to control:

- MAGIS COMBO / MAGIS COMBO PLUS;
- storage tank for D.H.W. production (the D.H.W. temperature is managed by the NTC probe);
- up to 2 solar circulation units for systems with manifolds arranged on different slopes;
- temperature probes (NTC - PT1000);
- on-off request dry contact;
- variable flow temperature of the generator, depending on the external temperature (a climatic curve is pre-selected);
- expansion boards to control the air conditioning system (3 of which for any mixed or direct zones);
- 1 expansion board for the additional functions, namely:
 - hot/cold switch-over on distinct systems (for example systems with radiant panel heating and fan-coil cooling);
 - recirculation pump management for DHW;
 - acquisition of a signal from a system that generates electrical energy (e.g. photovoltaic system);
- up to 3 humidity-temperature sensors or 4 Zone remote controls;
- up to 3 dehumidifiers.

On the other hand, in terms of the main settings that can/must be carried out, the System Manager allows you to acquire or programme:

- external temperature;
- system flow temperature;

- storage tank temperature (even through 2-3 probes, 1 of which refers to the solar-heated part of the boiler);
- by means of self-diagnosis, detection and display of error codes in the event of anomalies;
- date and time;
- differentiated selection and programming for each individual zone;
- programming the time periods for DHW production;
- anti-legionella function program;
- management of the heat/cooling sources.

• SYSTEM MANAGER

code 3.021522

MAGIS COMBO

32

REMOTE CONTROL OF ZONE (WITH SYSTEM MANAGER)



It is an electronic device equipped with a back-lit display to control and adjust the room's temperature and humidity. Connection to the System manager occurs via two BUS cables. It programs the relative room heat adjustment. It can be applied to the wall using the supplied screws and plugs. The kit must be powered at 230 Vac.

• OPTIONAL

code 3.023364

33

TEMPERATURE/HUMIDITY SENSOR (WITH SYSTEM MANAGER)



It is a room temperature and humidity probe, to be applied to the wall.

Differently to the zone remote control kit, in this case, the settings of all room parameters take place on the System Manager. The kit must be connected directly to the expansion board for zone management.

The kit must be powered at 24 Vac.

• OPTIONAL

code 3.021524

34

EXPANSION BOARD FOR ZONE MANAGEMENT (WITH SYSTEM MANAGER)



This component must be powered at 24 Vac and is mainly used for system zone management; in particular n°1 expansion kit must be used for each zone. The expansion kit manages pump, mixing valve and the dehumidifier of the same zone, acquiring the room request (temperature and humidity) for a determined zone. The following can be connected to this kit:

- the room temperature and humidity sensor;
- an on-off type request contact.

Installation takes place on a DIN guide for electric components from control board. **This board is envisioned as per standard in the 2 kits for zone systems** (see the following page).

• OPTIONAL

code 3.021547

35 DISTRIBUTION KIT TO THE SYSTEM (WITH SYSTEM MANAGER)



Two pre-packaged systems called: "**2 mixed zones kit**" and "**2 mixed zones and 1 direct zone kit**". They are comprised of 2 separate hydraulic manifolds (flow/return) + by-pass, thermometers to read the temperatures, motorised mixing valves, low energy consumption electro pumps and expansion boards for electric management.

The pumps included in the kit are distinguished for being very elastic, also thanks to the 7 operating curves that can be pre-set. All parts are already assembled and ready for operation exclusively in combination with the System Manager. With the aid of the expansions the 2 kits are governed by the System Manager during the central heating and cooling phases.

Acquisition of the outdoor temperature from system Manager enables you to select independent flow temperature curves for each of the 2 or 3 zones of the system (both with C.H. and cooling).

Inserting these kits into the system enhances overall comfort and energy savings.

35.1 DIMENSIONS AND CONNECTIONS

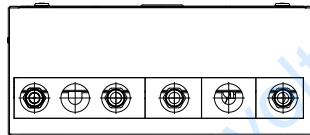
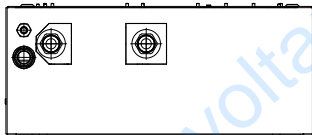

Height (mm)	Width (mm)	Depth (mm)
700	450	190

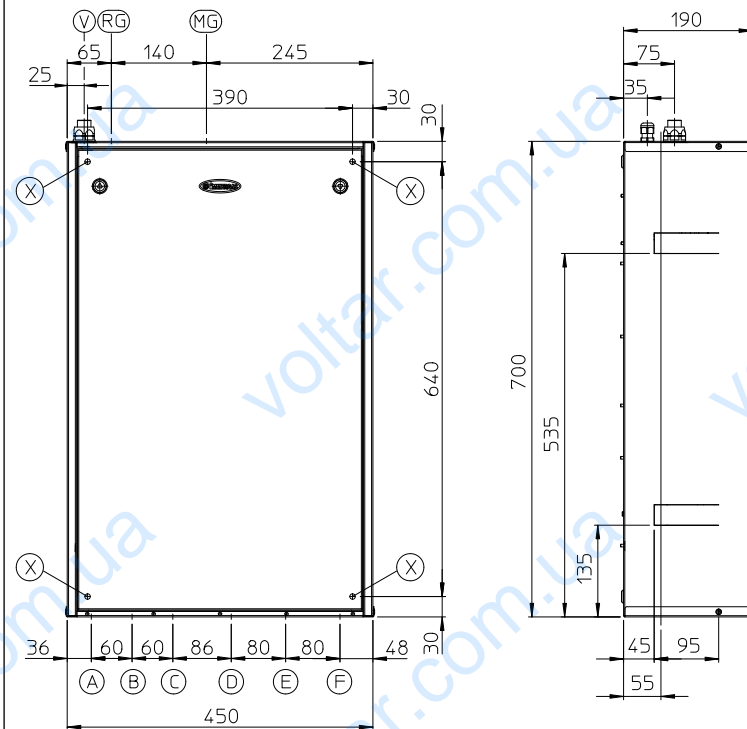

KEY:

- AR - Appliance return (G 3/4")
- AF - Appliance flow (G 3/4")
- V - Electrical connection
- X - Holes for wall-mounted installation of the kit

**• MIXED ZONES 2 KIT
code 3.021528**

- B - Zone 1 return (G 3/4")
- C - Zone 2 return (G 3/4")
- D - Zone 1 flow (G 3/4")
- E - Zone 2 flow (G 3/4")

**• 2 MIXED ZONES AND 1 DIRECT ZONE KIT
code 3.021527**

- A - Zone 3 return (G 3/4")
- B - Zone 1 return (G 3/4")
- C - Zone 2 return (G 3/4")
- D - Zone 1 flow (G 3/4")
- E - Zone 2 flow (G 3/4")
- F - Zone 3 flow (G 3/4")

MAGIS COMBO

35.2

TECHNICAL DATA

		Mixed zones 2 kit	2 mixed zones and 1 direct zone kit
Maximum nominal pressure	bar	3	3
Maximum operating pressure	°C	90	90
Low temperature circuit minimum set point regulation temperature	°C	25	25
Low temperature circuit maximum set point regulation temperature	°C	50 ÷ 80	50 ÷ 80
Water content in device	litres	1.5	1.9
Total head available in non-mixed zone with 1000 l/h flow rate (max.)	kPa (m H ₂ O)	--	43 (4.30)
Total head available in mixed zone (mixing valve closed) with 1000 l/h flow rate (max.)	kPa (m H ₂ O)	54.50 (5.50)	54.50 (5.50)
Empty device weight	kg	21.1	23.1
Full device weight	kg	22.6	25.0
Electrical connection	V/Hz	230/50	230/50
Maximum input	A	0.9	1.2
Installed electric power	W	105	150
Power in Stand-by	W	9.5	9.5
Electric plant protection	-	IPX4D	IPX4D
Hydraulic side generator - kit maximum distance	m	15	15

35.3

CIRCULATION PUMP SETTINGS AND CONFIGURATIONS

The kits are supplied with circulating pumps fitted with speed regulator. These settings are suitable for most systems.

For proper operation one must select the most suitable type of operation for the system and select a speed between 2 and 7.

- **Program constant head ($\Delta P C$)**. The circulator pump maintains the pressure level (head) constant as the system heat demand decreases (flow rate reduction). With these settings, the circulator pump is suitable for all floor systems where all the circuits must be balanced for the same drop in head. One can select the operating level from minimum to maximum by turning the selector switch clockwise in the relative power scale (refer to the drawing below).

- **Program proportional head ($\Delta P V$)**. This allows the pressure level (head) to be proportionally reduced as the system heat demand decreases (flow rate reduction). Thanks to this function, the electric power consumption of the circulator pump is reduced further: the energy (power) used by the pump decreases according to the pressure level and flow rate. With this setting, the pump guarantees optimal performance in most heating systems, proving particularly suitable in single-pipe and two-pipe installations. Any noise originating from the water flow in the pipes, valves and radiators is eliminated by reducing the head. One can select the operating level from minimum to maximum by turning the selector switch anticlockwise on the relative power scale (refer to the drawing below).

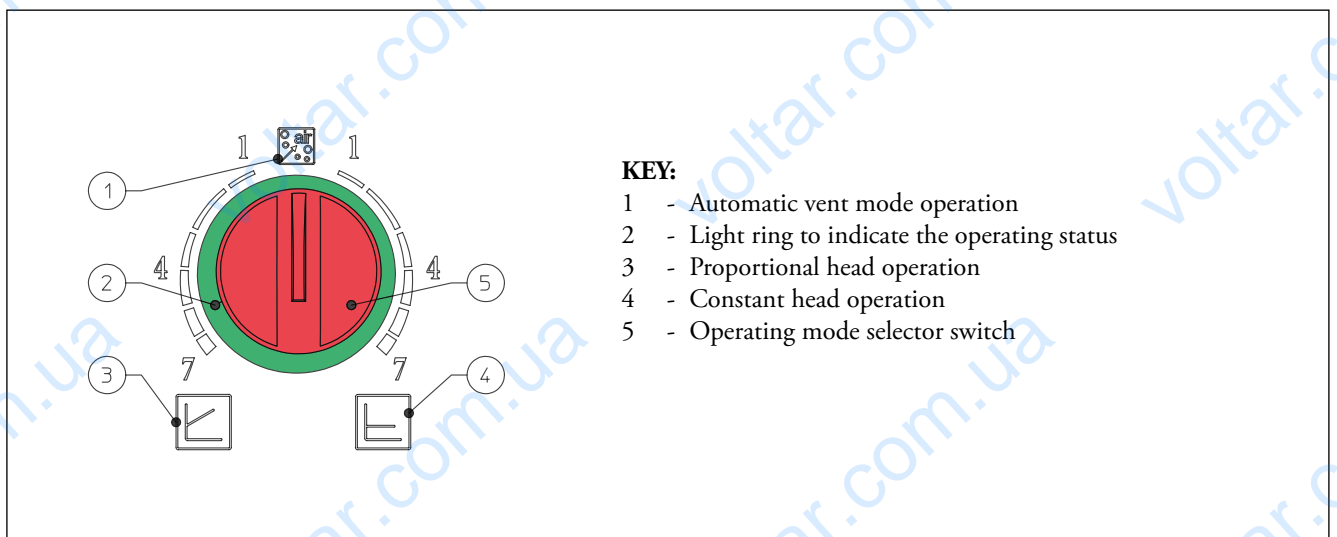

35.4 GRAPHS OF CIRCULATION PUMP FLOW RATE-ABSORPTION-HEAD

The kit contains an electronic low consumption circulation pump, whose flow rate/head features are shown in the graph below.

All pumps in the kit are suitable for operation with heat and cold carrying fluid.

ZONE MIXED WITH A CLOSED MIXING VALVE

WILO YONOS PARA RS 15-7 RKA CM 130

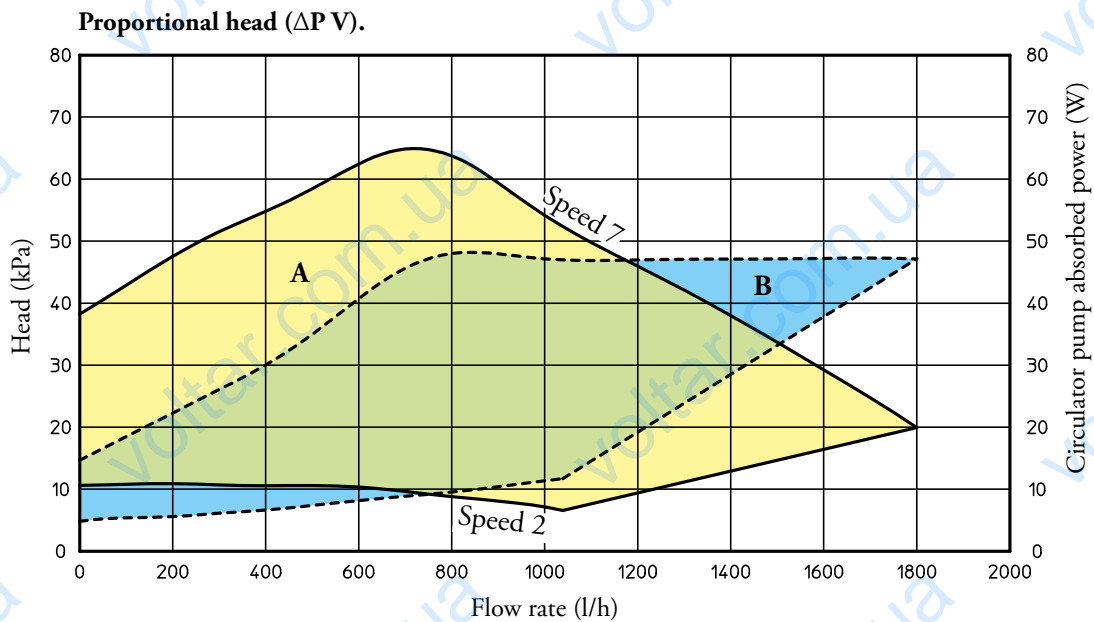
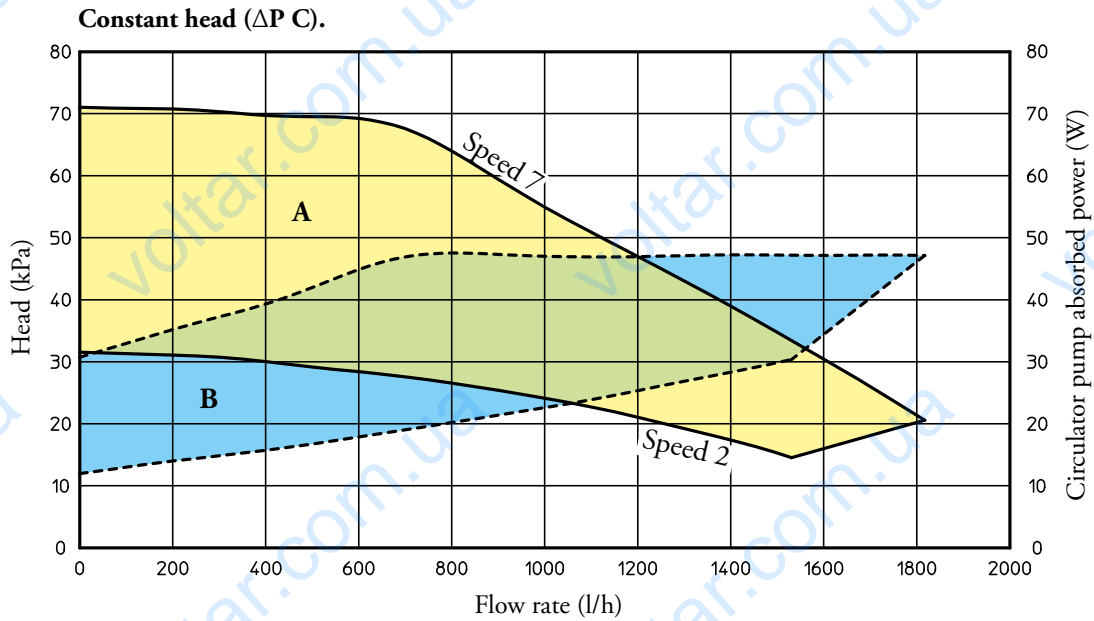

KEY:

- A = Head available at speed 2 ÷ 7
- B = Power absorbed by the system pump (dotted area)

EEl ≤ 0.20

MAGIS COMBO

35.5 GRAPHS OF CIRCULATION PUMP FLOW RATE-ABSORPTION-HEAD

The kit contains an electronic low consumption circulation pump, whose flow rate/head features are shown in the graph below.

All pumps in the kit are suitable for operation with heat and cold carrying fluid.

ZONE MIXED WITH AN OPEN MIXING VALVE AND DIRECT ZONE

WILO YONOS PARA RS 15-7 RKA CM 130

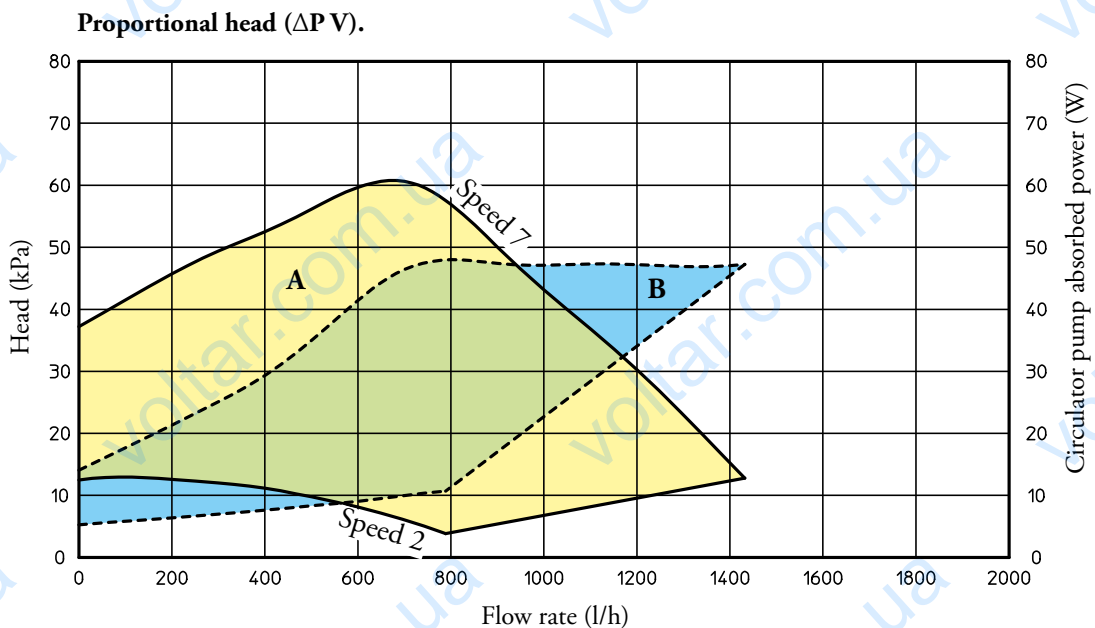
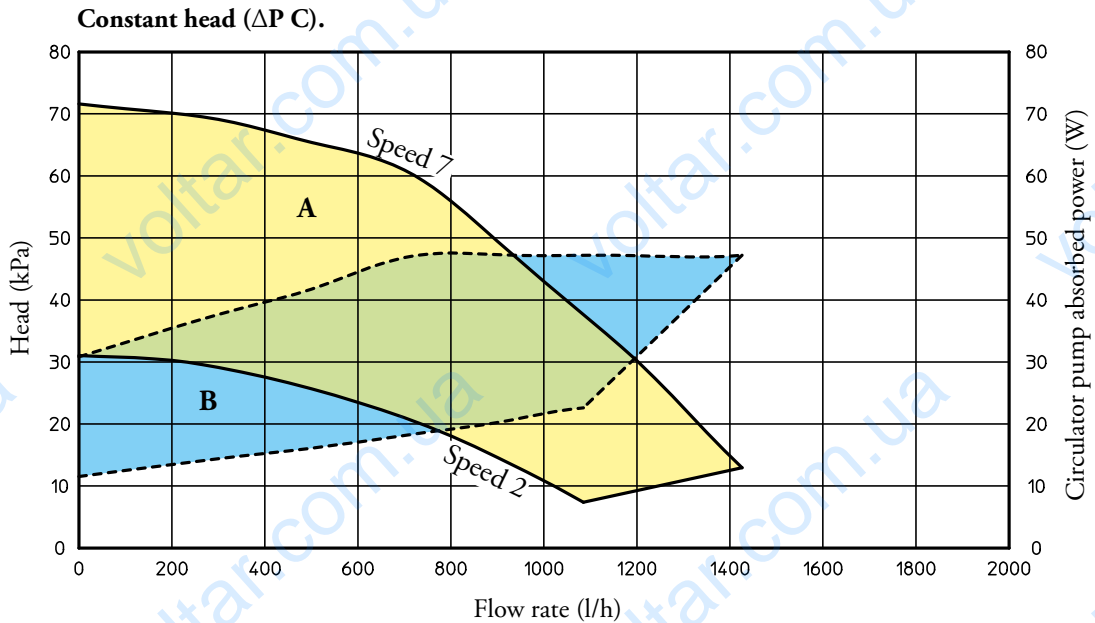

KEY:

A = Head available at speed 2 ÷ 7

B = Power absorbed by the system pump (dotted area)

EEI ≤ 0.20

36

DEHUMIDIFIER



Designed to be coupled to cooling plants with radiant panels, the dehumidifier allows to keep the percentage of relative humidity in the room within the comfort values, preventing the possible formation of condensate on the walls.

The dehumidifier, which is designed to be installed vertically on the wall (recessed), has pre- and post-cooling coils.

These components allow excellent control of the air temperature and humidity.

However, it can function without the aid of pre and post cooling water coils, thus allowing to dehumidify when the cooling system is off, typical of mid-season.

In compliance with European Directives, it has EC declaration of conformity.

Dehumidification can take place:

- with **neutral air**: without variation of the air temperature, dehumidifies internal rooms;
- with **cooled air**: contributes to cooling the rooms, as well as reducing the internal relative humidity.

This operation can only be obtained with the System manager and its expansions, to couple the dehumidifier directly to MAGIS COMBO, see the paragraph "MAGIS COMBO management electronic functions".

36.1

DIMENSIONS AND CONNECTIONS

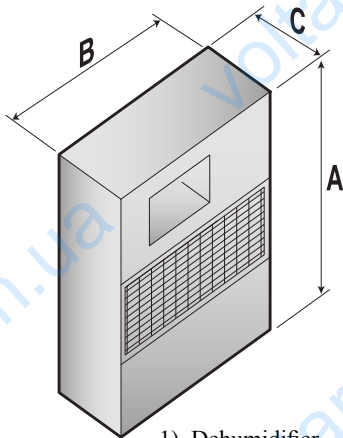

1) Dehumidifier

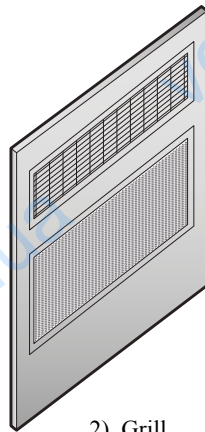

2) Grill

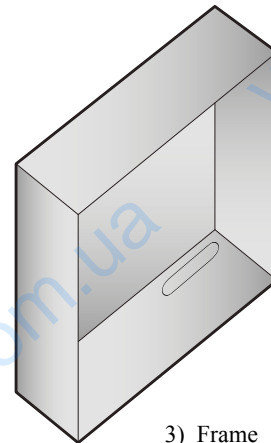

3) Frame

Model	A (mm)	B (mm)	C (mm)
1	680	545	221
2	750	660	20
3	703	605	228

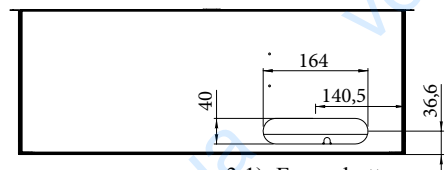

3.1) Frame bottom

- **DEHUMIDIFIER** **code 3.021529**
(frame and grid to be purchased separately)

Connect the F-R (female) 1/2" fittings of the dehumidifier to the cooling system, using the measurements in fig. 3.1

MAGIS COMBO

36.2

FUNCTIONING PRINCIPLE

The **humid air** is taken from the room through the fan (7) and made to pass through the filter(1) and the pre-cooling water coil (2), where the air itself is cooled and taken to a condition near to the saturation curve. It then passes through the evaporating coil (3) where air is further cooled and dehumidified

LEGENDA:

- 1 - Air filter
- 2 - Pre-cooling coil
- 3 - Evaporator
- 4 - Compressor
- 5 - Condenser
- 6 - Post-cooling coil
- 7 - Fan
- 8 - Throttle valve
- 9 - Dryer filter
- 10 -cut-off valve

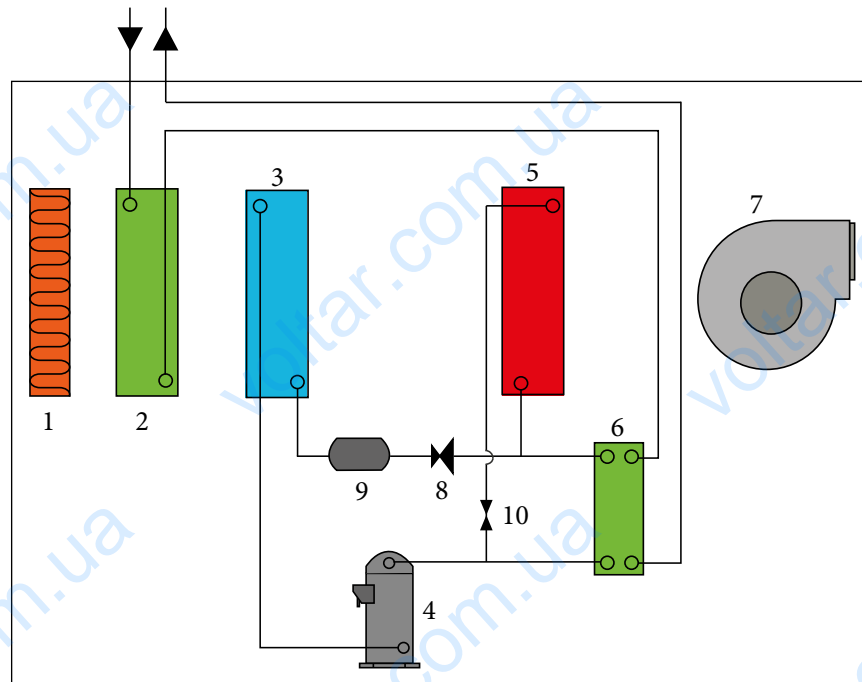

Dehumidification mode with neutral air

The cooling circuit works by partially condensing in water through the heat exchanger (6) and partially in air through the heat exchanger (5); accordingly air post-heating is performed and this air is sent into the room in thermally neutral conditions

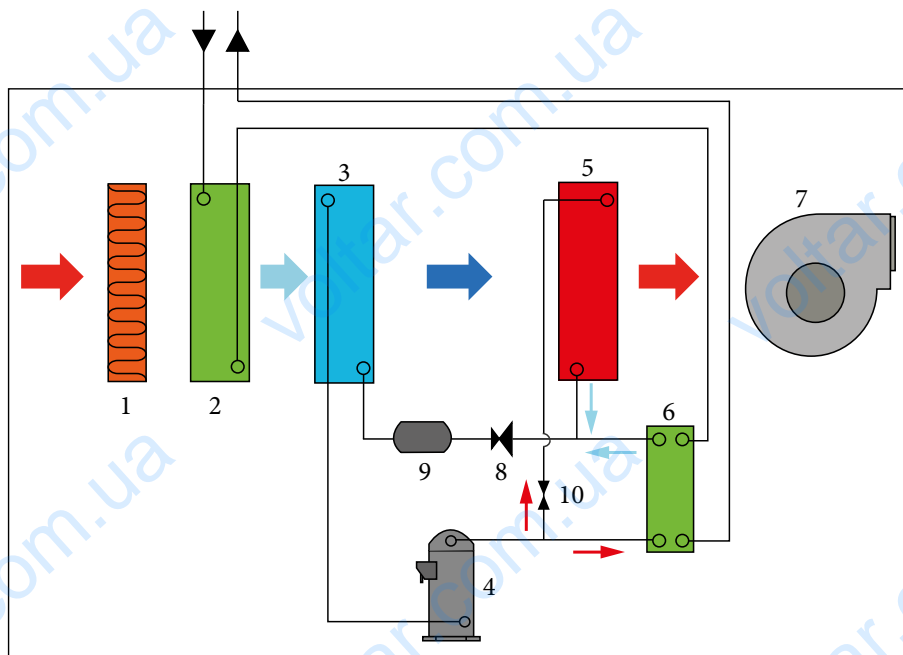

Dehumidification mode with cooled air

In this case, the cooling circuit performs 100% of condensation in water via exchanger (6). The condenser (5) is cut-off via the valve (10) and the air sent into the room is the same - cooled and dehumidified - at evaporator outlet (3)

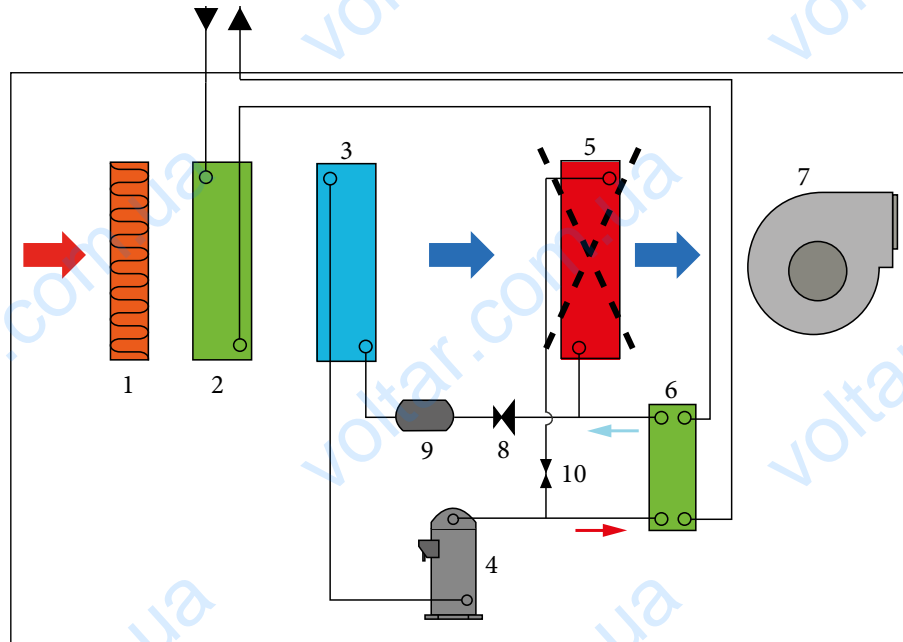

36.3

**DEHUMIDIFIER LAYOUT AND WIRING DIAGRAMS
(WITH SYSTEM MANAGER AND EXPANSION)**

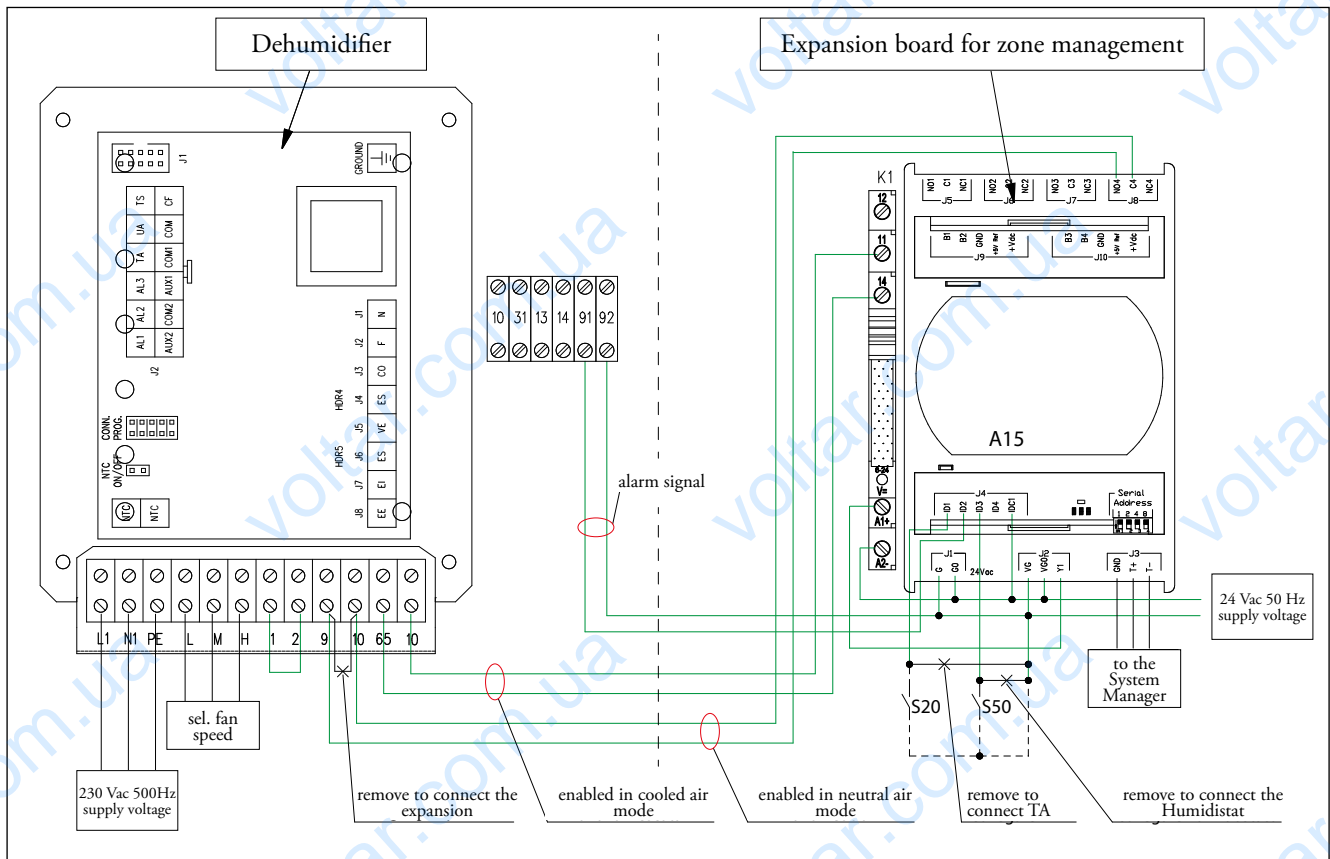

MAGIS COMBO

36.4 TECHNICAL DATA

Refrigerant		R134a
umidity removed in neutral air condition ⁽¹⁾	litres/24h	20.1
Cooling capacity ⁽¹⁾	W	1250
Nominal water input	l/h	150
Head losses	kPa	7.8
Water supply temperature operating field	°C	15 ÷ 45
work humidity field	%	40 ÷ 90
Air flow rate	m ³ /h	250
Fan useful static head (maximum speed)	Pa	43
Sound pressure ⁽³⁾	dB(A)	35
Sound power	dB(A)	43
Power absorbed ⁽¹⁾	W	340
Power Supply	V/Ph/Hz	230/1~/50
Maximum power absorbed ⁽²⁾	W	450
Nominal current absorbed ⁽¹⁾	A	2.5
Maximum current absorbed ⁽²⁾	A	2.8
Hydraulic F-R connections		1/2" F
Weight	kg	38

The data given refer to the following conditions:

¹⁾ Room temperature 26 °C; relative humidity 65% with coil inlet water temperature of 15 °C.

²⁾ Room temperature 35 °C; relative humidity 80%.

³⁾ Sound pressure level measured in free field at 1 m from the machine, in compliance with UNI EN ISO 3746/97

36.5 HEAD LOSS OF THE HYDRAULIC CIRCUIT

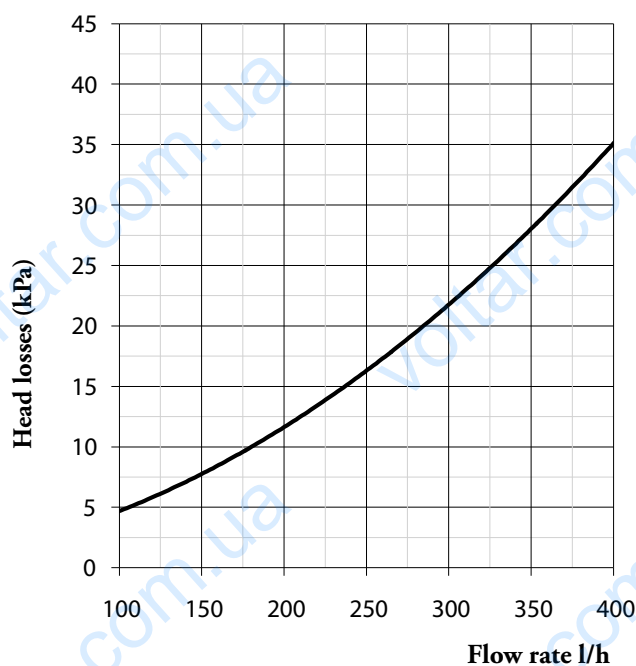

37 OPTIONAL FOR DIRECT COUPLING TO MAGIS COMBO / COMBO PLUS

HEAT REGULATION OPTIONALS	
CAR^{v2} (Comando Amico Remoto modulating remote control) device class V* or VI code 3.021395	Temperature and humidity sensor kit device class V or VI* code 3.021524
CRONO 7 (Weekly digital chrono-thermostat) device class IV* or VII code 3.021622	CRONO 7 WIRELESS device class IV* or VII code 3.021624
External Probe device class II* or VI or VII code 3.015266	Humidistat kit (operates on the Dehumidifier according to the humidity detected in the room and according to what is set on the device) code 3.023302
OTHER OPTIONALS	
2 zone kit (1 direct zone and 1 mixed zone) (wall-hung or recessed for mixed systems) code 3.026301	3-way valve kit (used as hot/cold system diverter) code 3.020632
75-Litre inertial storage kit (can be installed wall-hung vertically or on floor) code 3.027288	Bracket kit for wall mounting Inertial storage tank (for wall-mounted installation) code 3.027290
2-Relay board kit for coupling MAGIS COMBO ErP (for dehumidifier control) code 3.026302	Dehumidifier kit code 3.021529
Dehumidifier grid kit code 3.022147	Dehumidifier frame kit code 3.022146
Polyphosphate dispenser kit (indoor only) code 3.017323	Antifreeze kit up to -15 °C (to protect the heat generator) code 3.017324
Configurable relay interface kit (to control the DHW recirculation via CAR ^{v2}) code 3.015350	Solar inlet probe kit (only for instant MAGIS COMBO) code 3.021452
Contact NTC probe kit for storage tank (also used to read the temperature of a possible Puffer) code 3.019375	R410A circuit connection kit (to allow easy connection of the cooling circuit also in case of pipes that arrive at the rear) code 3.026089
Safety marker thermostat kit code 3.019229	Cover kit B₂₃ MAGIS COMBO code 3.027082
Compact condensate drain pump kit code 3.026374	Condensate neutraliser kit code 3.019857
Propane air kit code 3.027664	

*Device class (REF. Communication of the European Commission 2014/C 207/02) with factory settings.

MAGIS COMBO

38

OPTIONAL IN THE PRESENCE OF SYSTEM MANAGER

HEAT REGULATION OPTIONALS	
System manager kit device class VI* or VIII code 3.021522	Zone remote control kit device class V or VI* code 3.023364
Temperature and humidity sensor kit device class V or VI* code 3.021524	Humidistat kit (operates on the Dehumidifier according to the humidity detected in the room and according to what is set on the device) code 3.023302
CRONO 7 (Weekly digital chrono-thermostat) device class IV* or VII code 3.021622	CRONO 7 WIRELESS device class IV* or VII code 3.021624
OTHER OPTIONALS	
Mixed zones 2 kit (wall-hung or recessed) code 3.021528	2 mixed zones and 1 direct zone kit (wall-hung or recessed for mixed systems) code 3.021527
75-Litre inertial storage kit (can be installed wall-hung vertically or on floor) code 3.027288	Bracket kit for wall mounting Inertial storage tank (for wall-mounted installation) code 3.027290
Low temperature safety kit for low temperature systems and system distribution kit code 3.013794	3-way valve kit (used as hot/cold system diverter) code 3.020632
Probe kit for solar manifold temperature (coupled with the system manager) code 3.019374	Relay kit for dehumidifier cooling request (EMR 12 Vdc) code 3.023945
Expansion kit to manage zone or for auxiliaries code 3.021547	Dehumidifier kit code 3.021529
Dehumidifier grid kit code 3.022147	Dehumidifier frame kit code 3.022146
Contact NTC probe kit for storage tank (also used to read the temperature flow temperature in the zones of the system) code 3.019375	R410A circuit connection kit (to allow easy connection of the cooling circuit also in case of pipes that arrive at the rear) code 3.026089
Antifreeze kit up to -15 °C (to protect the heat generator) code 3.017324	Cover kit B₂₃ MAGIS COMBO code 3.027082
Compact condensate drain pump kit code 3.026374	Condensate neutraliser kit code 3.019857
Propane air kit code 3.027664	

*Device class (REF. Communication of the European Commission 2014/C 207/02) with factory settings.

39

MAIN INERTIAL STORAGE TANK TECHNICAL FEATURES

Minimum water content is mainly important to provide proper execution of heat pump defrosting cycles.

In this regard, the minimum amount of water must be 7 l/kW of the machine's power for any type of system.

It is also important to check that the dehumidifier line has a minimum of **3 l/kW** of the machine (dehumidifier hydraulic circuit connection reference).

The flywheel naturally also guarantees normal operation of MAGIS COMBO with systems divided into zones (therefore, with variable water content in circulation).

Improved operation with the thermal flywheel is obtained, for example, with fan coils used in cooling mode (a condition in which the flow temperature is very low and significant heat load changes vary according to the number of active fan coils).

MAIN FEATURES:

- Stainless steel cylindrical storage tank Ø 415 with 75-litre capacity;
- The inertial storage tanks are fully insulated with 50 mm thick

insulating material, complete with on-view PVC coating;

- For practical connection, the inertial storage tank has 4 M connections of G 1" and two plugs for unused fittings;
- G 1/2" draining valve located at the bottom;
- G 1/2" fitting including cap on the top of the inertial storage tank for possible air vent;
- There is a probe point;
- A kit is available (optional) consisting of a bracket with 4 plugs to be able to hang it on the wall;
- Any check valves on other connections must be provided separately;
- Thanks to the 4 connections present, the storage tank can also be used as hydraulic separator, as well as thermal flywheel.

39.1

75-LITRE INERTIAL STORAGE TANK (Code 3.027288)

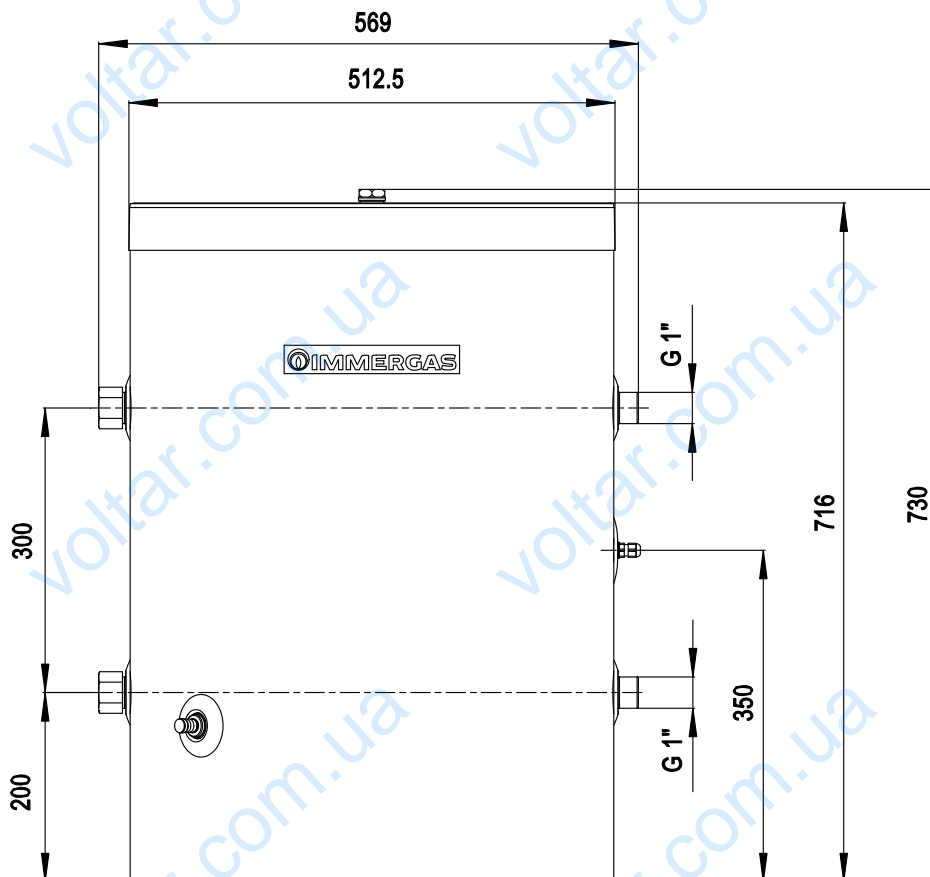



DICHIARAZIONE DI CONFORMITÀ UE

(N. 301116)

(3.026440) - AUDAX PRO 5
(3.025447) - AUDAX PRO 8
(3.026441) - AUDAX PRO 10

Nome e indirizzo del fabbricante o del suo rappresentante autorizzato:

IMMERGAS S.p.A via Cisa Ligure 95, 42041 Brescello RE Italy

La presente dichiarazione di conformità è rilasciata sotto la responsabilità esclusiva del fabbricante.

Oggetto della dichiarazione:

POMPA DI CALORE ARIA/ACQUA

L'oggetto della dichiarazione di cui sopra è conforme alla pertinente normativa di armonizzazione dell'Unione:

DIRECTIVE 2004/108/EC
DIRECTIVE 2006/95/EC

Riferimento alle pertinenti norme armonizzate utilizzate o riferimenti alle altre specifiche tecniche in relazione alle quali è dichiarata la conformità:

EN 55014-1/2006; +A1:2009; +A2:2011
EN 55014-2:1997; +A1:2001; +A2:2008
EN 61000-3-2/2006; +A1:2009; +A2:2009
EN 61000-3-3 (2008)
EN 60335-1:2002; +A11:2004; +A12:2006; +A2:2006; +A13:2008
EN 60335-2-40:2003; +A11:2004; +A12:2005; +A1:2006
EN 62233:2008

Firmato a nome e per conto di:

IMMERGAS S.p.A.

Brescello, 02/05/2016

Direzione R&D Guareschi Mauro

IMMERGAS S.p.A.

Direzione Ricerca & Sviluppo
Mauro Guareschi



IMMERGAS S.p.A. a socio unico - Via Cisa Ligure, 95 - 42041 Brescello (RE) Italia - Cap. Soc. Euro 2.251.349,00 - Reg. Imprese di RE n. 150792
P.I. e C.F. 0072030359 - Tel. (+39) 0522 489011 s.a. - Fax (+39) 0522 011 - Generale & Amministrativa 489397 - Comale Italia 489102 - Comale Estero 489178
Ricerca e Sviluppo 489728 - Assistenza 489726 - Ordini e Spedizioni 489708 - Ufficio Acquisti 489328 - Magazzino Ricambi 489808 | [immergas.com](http://www.immergas.com)



DICHIARAZIONE DI CONFORMITÀ UE

(N. 321116)

(3.027232) - MAGIS COMBO
(3.027233) - MAGIS COMBO PLUS

Nome e indirizzo del fabbricante o del suo rappresentante autorizzato:

IMMERGAS S.p.A via Cisa Ligure 95, 42041 Brescello RE Italy

La presente dichiarazione di conformità è rilasciata sotto la responsabilità esclusiva del fabbricante.

Oggetto della dichiarazione:

CALDAIA A CONDENSAZIONE

L'oggetto della dichiarazione di cui sopra è conforme alla pertinente normativa di armonizzazione dell'Unione:

DIRECTIVE 2009/142/CE
Reg. UE 813/2013

EC DIRECTIVE ELECTROMAGNETIC COMPATIBILITY 2014/30/UE;
EC DIRECTIVE LOW VOLTAGE 2014/35/UE;

Riferimento alle pertinenti norme armonizzate utilizzate o riferimenti alle altre specifiche tecniche in relazione alle quali è dichiarata la conformità:

EN 15502-1:2012+A1:2015; EN 15502-2-1:2012; EN 15036-1:2007;
EN 60335-2-102:2016; ENEN 60335-1:2002; +A11:2004; +A12:2006; +A2:2006; +A13:2008
EN 60335-2-40:2003; +A11:2004; +A12:2005; +A1:2006
EN 62233:2008
EN 55014-1/2006; +A1:2009; +A2:2011
EN 55014-2:1997; +A1:2001; +A2:2008
EN 61000-3-2/2006; +A1:2009; +A2:2009
EN 61000-3-3 (2008)

Firmato a nome e per conto di:

IMMERGAS S.p.A.

Brescello, 22/11/2016

Direzione R&D Guareschi Mauro

IMMERGAS S.p.A.

Direzione Ricerca & Sviluppo
Mauro Guareschi



IMMERGAS S.p.A. a socio unico - Via Cisa Ligure, 95 - 42041 Brescello (RE) Italia - Cap. Soc. Euro 2.251.349,00 - Reg. Imprese di RE n. 150792
P.I. e C.F. 0072030359 - Tel. (+39) 0522 489011 s.a. - Fax (+39) 0522 011 - Generale & Amministrativa 489397 - Comale Italia 489102 - Comale Estero 489178
Ricerca e Sviluppo 489728 - Assistenza 489726 - Ordini e Spedizioni 489708 - Ufficio Acquisti 489328 - Magazzino Ricambi 489808 | [immergas.com](http://www.immergas.com)

APPENDIX: LOGIC OF OPERATION AND ADJUSTMENT

40 MAGIS COMBO OPERATING PRINCIPLES

The control logic of a MAGIS COMBO systems, establishes various operating situations described below:

CENTRAL HEATING MODE

When operating in winter heating mode the switching logic between condensation generator and Heat Pump circuit can be selected between 2 options:

- With variable external switching temperature according to the flow temperature (“AUTO” mode);
- With fixed external switching temperature (“MANUAL” mode).

The diagram below shows the winter heating operation via the Heat Pump (1).

In these conditions, the condensation generator (2) may simultaneously activate to heat the D.H.W.

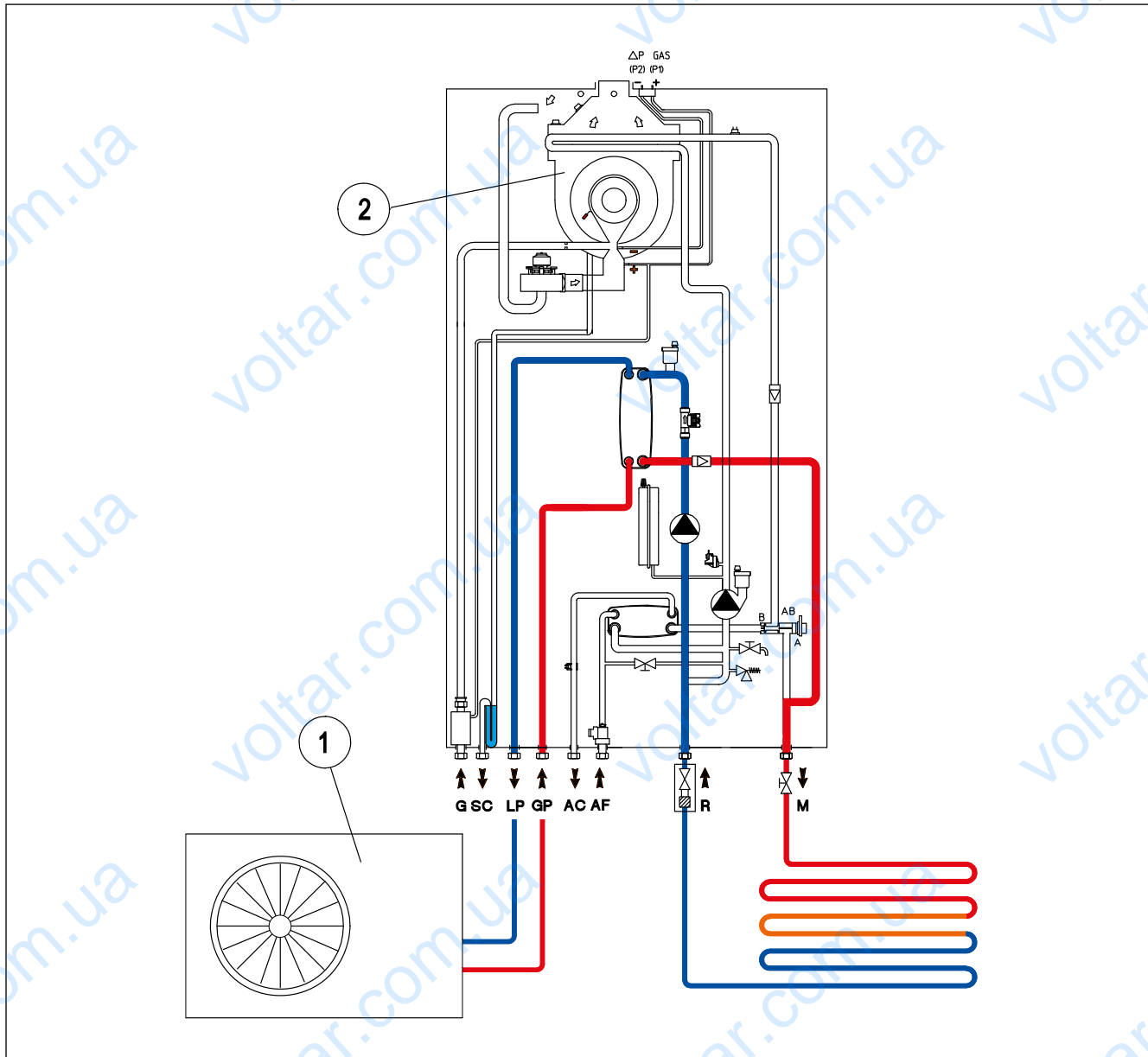

MAGIS COMBO

If the Heat Pump (1) is unable to bring the system to temperature within a certain time, the condensation generator (2) activates (see diagram below).

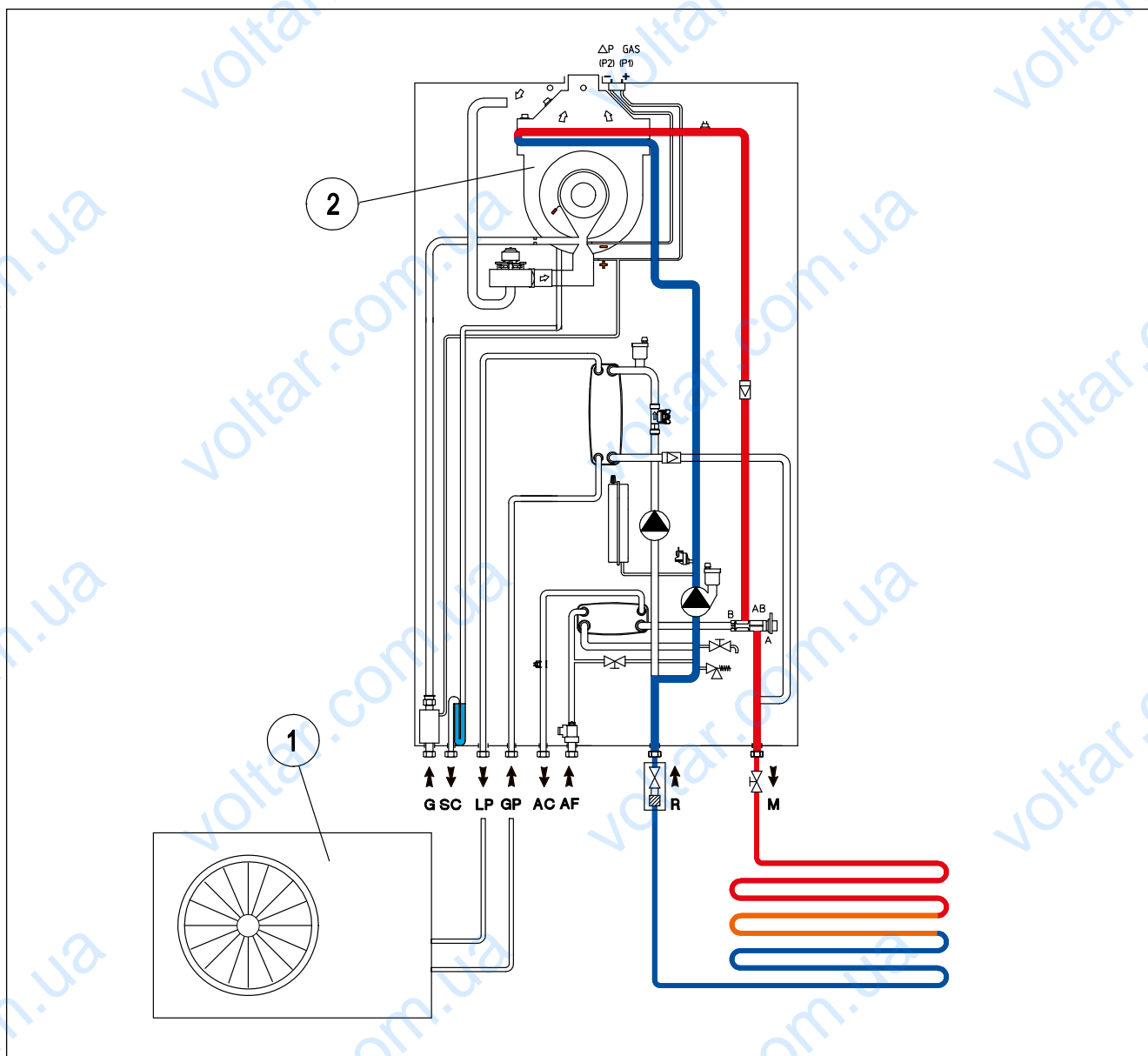

COOLING MODE

During the summer season only the Heat Pump (1) will operate the system circuit.

It occurs through the activation of the cooling circuit, according to the diagram below.

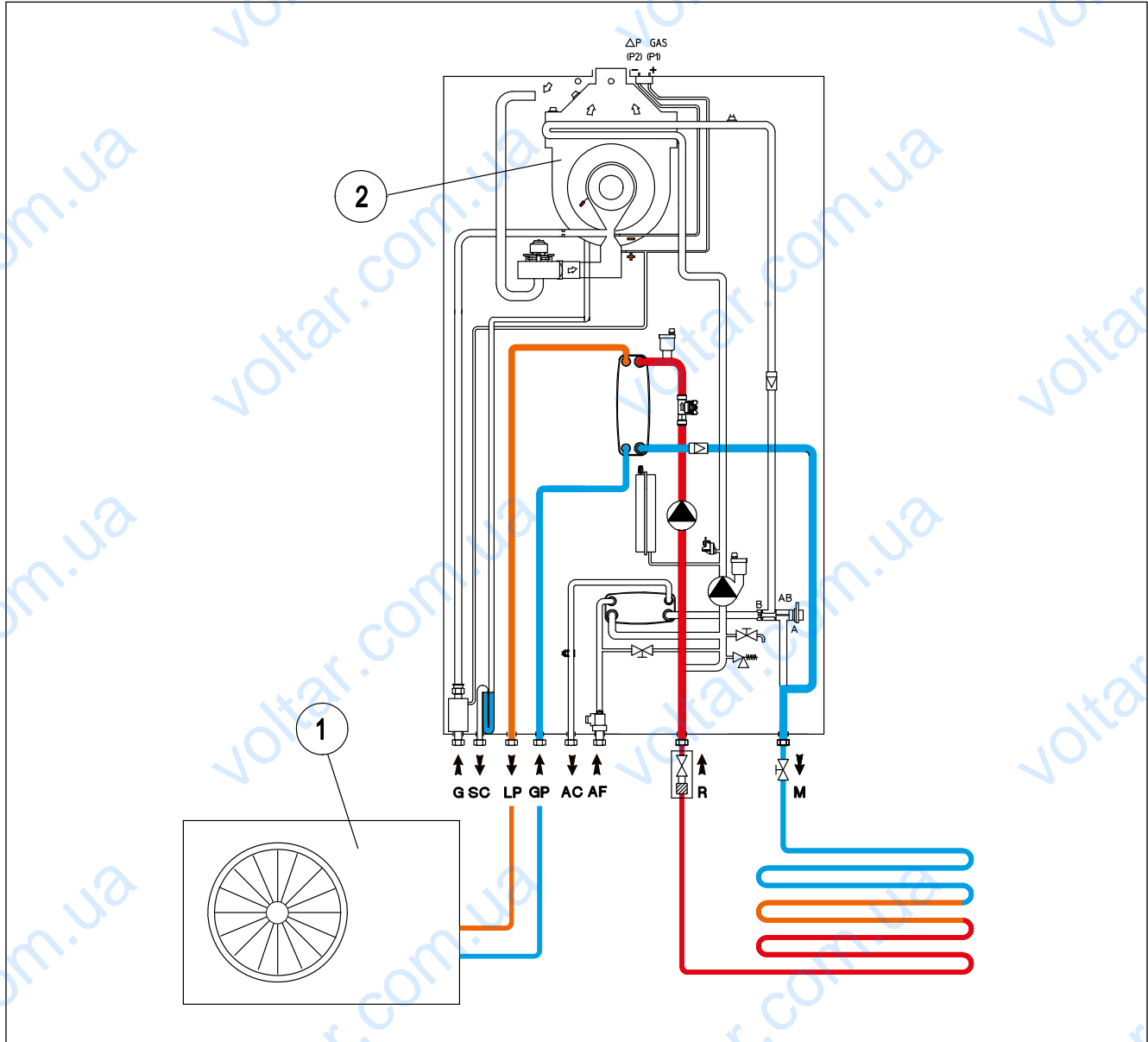

MAGIS COMBO

D.H.W. MODE

In Instant MAGIS COMBO the D.H.W. is heated by the condensation generator (2) (obviously because of exchanged power).

The Instant MAGIS COMBO can be coupled with a separate storage tank unit, by connection in series: this also takes advantage of the Thermal Solar Systems as Renewable Energy Source (RES), to supplement the production of D.H.W.

Or you can use a heat pump water heater (e.g. RAPAX), to supplement the production of D.H.W., again to exploit the RES.

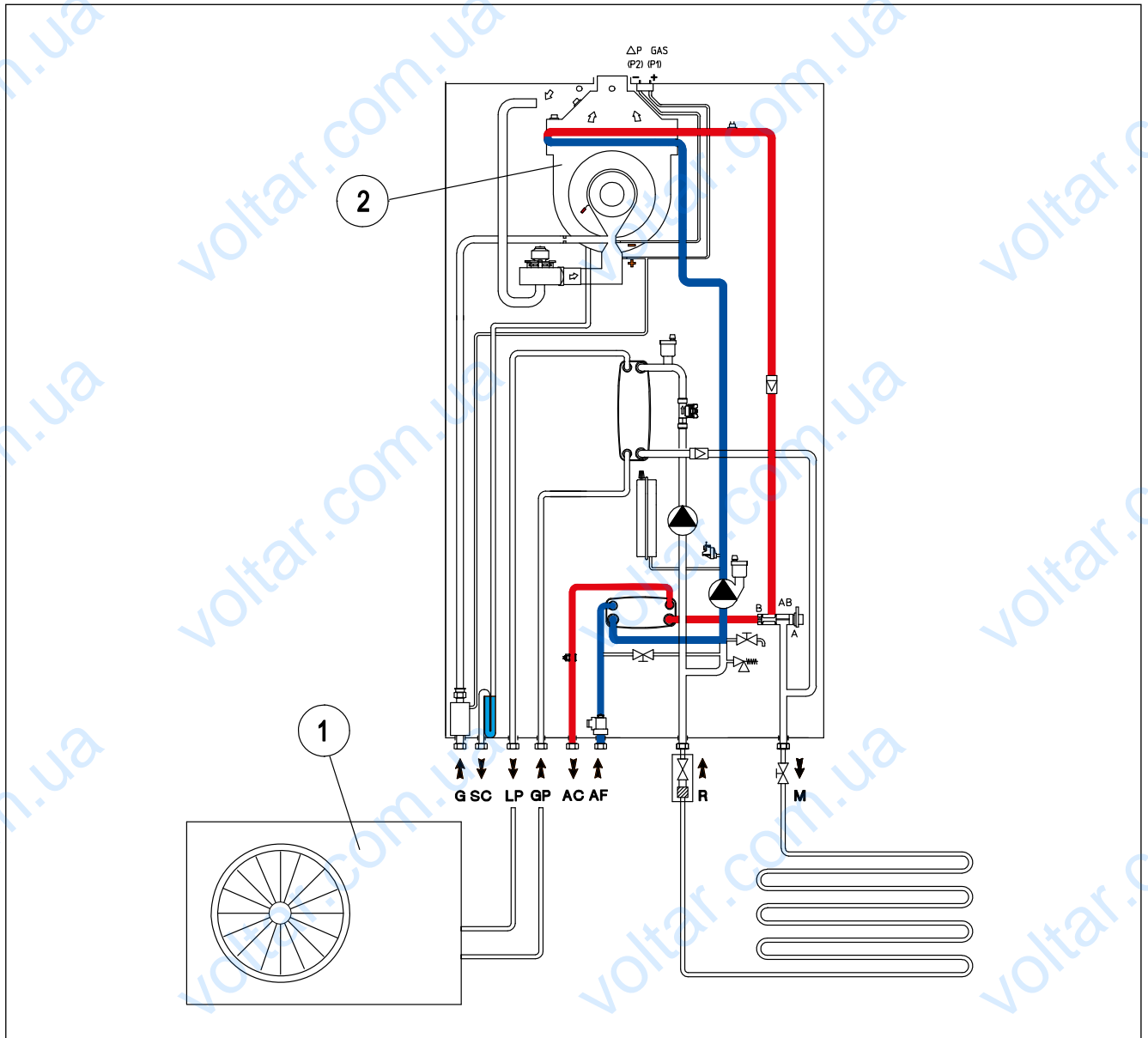

D.H.W. MODE + COOLING MODE

Given that in the Instant version it is the condensation generator (2) to ensure the production of D.H.W., in the summer the Heat Pump (1) can simultaneously activate to ensure cooling the rooms.

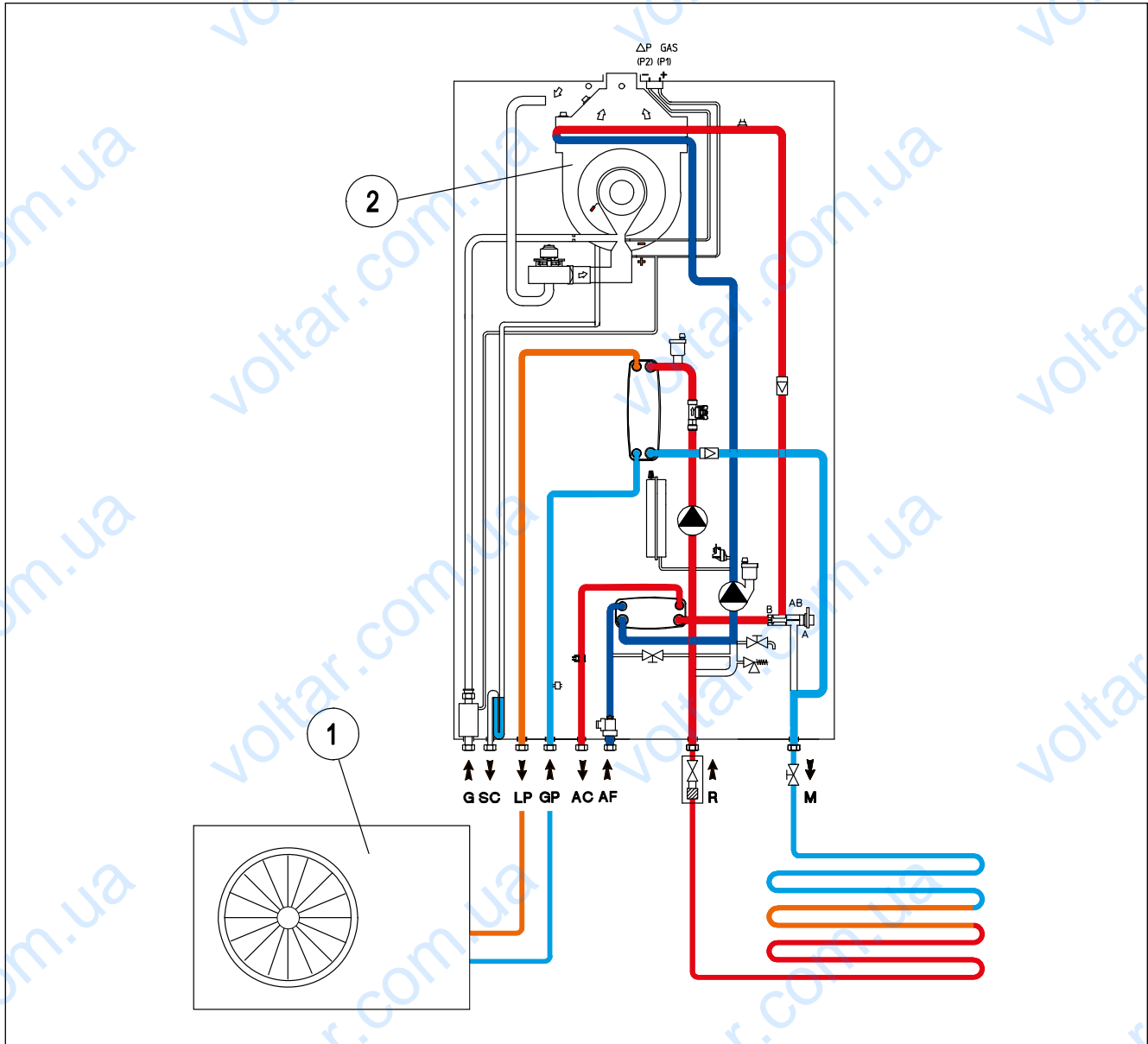

MAGIS COMBO PLUS

41

MAGIS COMBO PLUS OPERATING PRINCIPLES

The control logic of a MAGIS COMBO PLUS systems, establishes various operating situations described below:

CENTRAL HEATING MODE

When operating in winter heating mode the switching logic between condensation generator and Heat Pump circuit can be selected between 2 options:

- With variable external switching temperature according to the flow temperature (“AUTO” mode);
- With fixed external switching temperature (“MANUAL” mode).

The diagram below shows the winter heating operation via the Heat Pump (1).

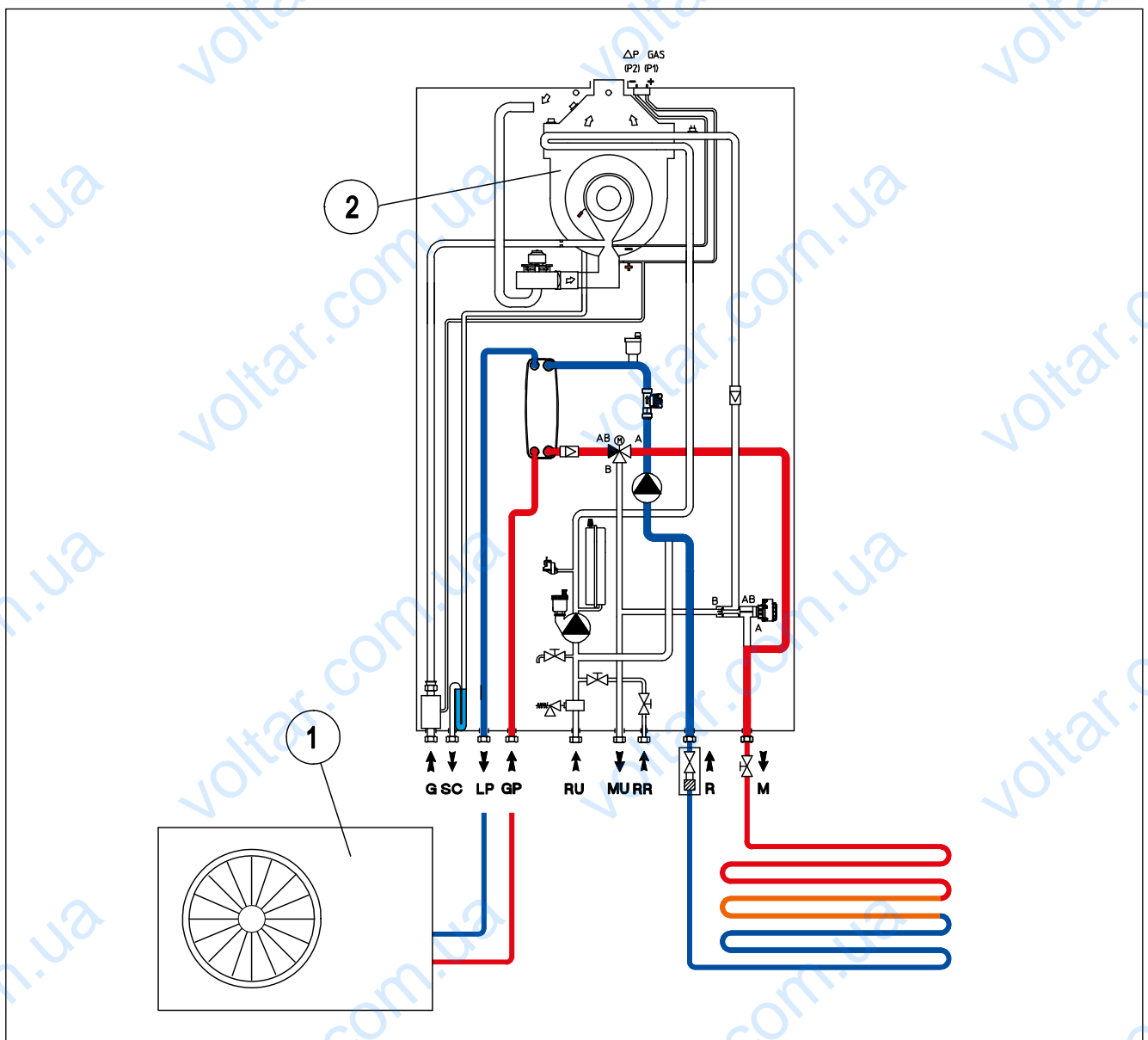

MAGIS COMBO PLUS

If the Heat Pump (1) is unable to bring the system to temperature within a certain time, the condensation generator (2) activates (see diagram below).

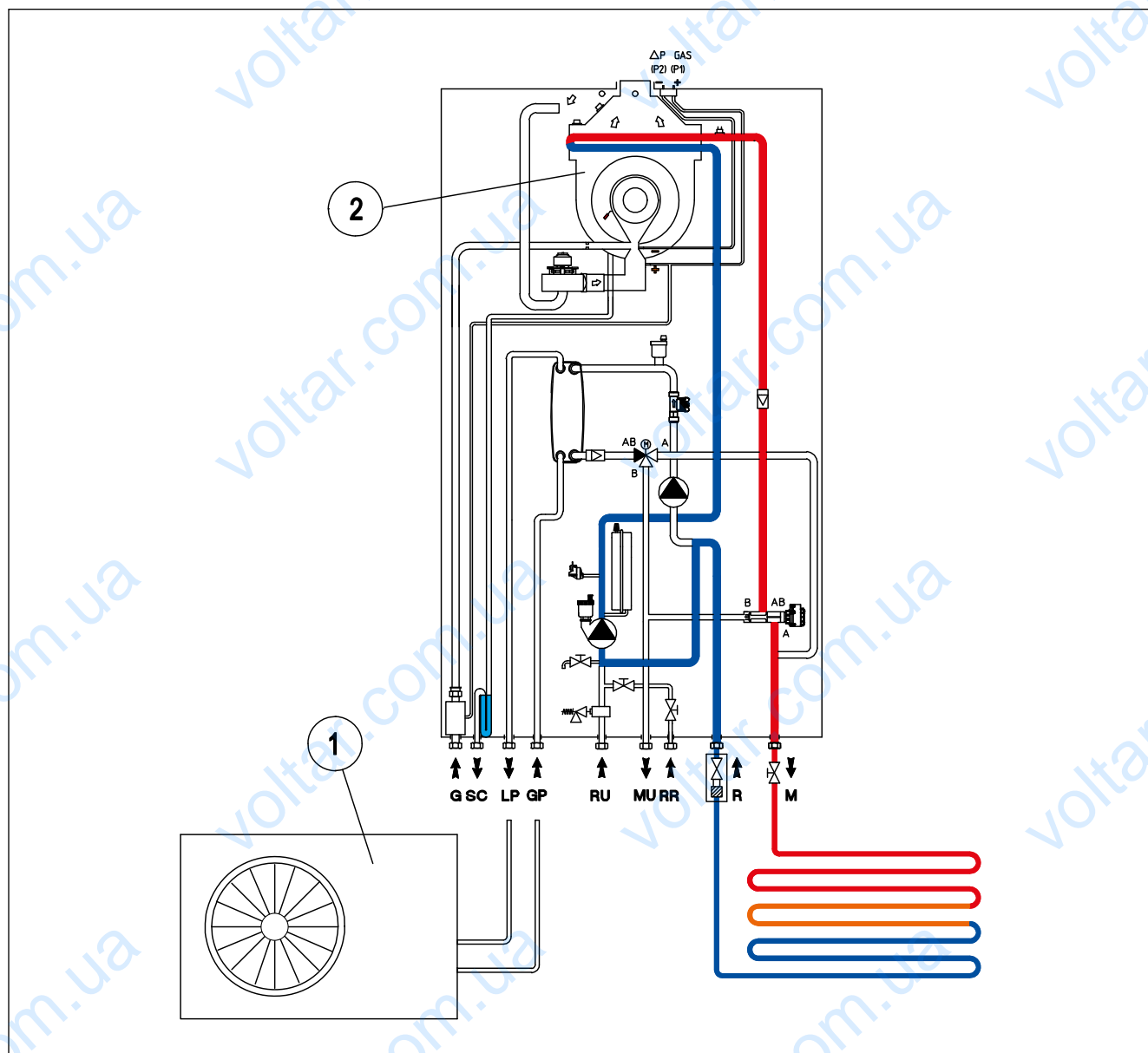

MAGIS COMBO PLUS

COOLING MODE

During the summer season only the Heat Pump (1) will operate the system circuit.

It occurs through the activation of the cooling circuit, according to the diagram below.

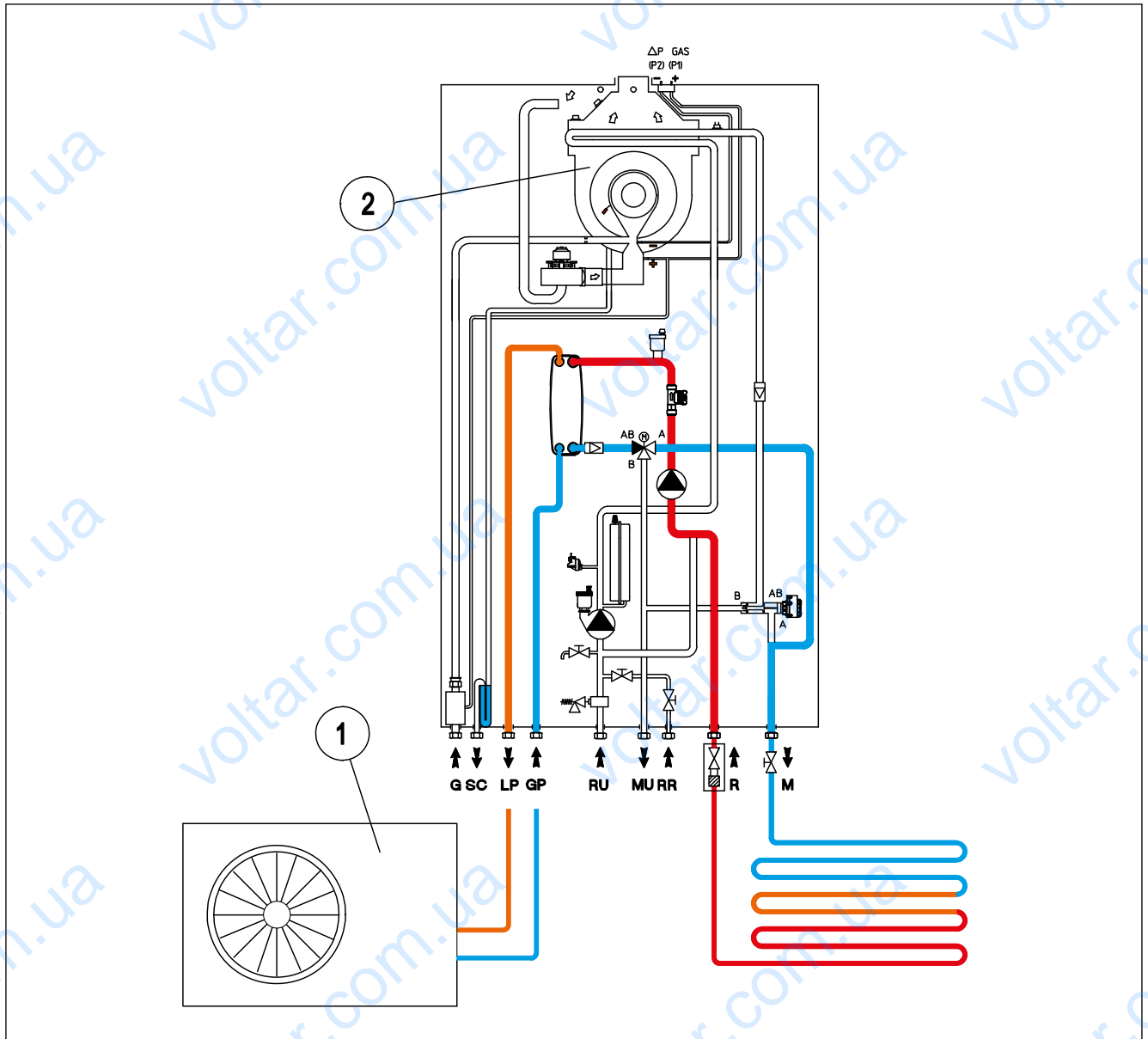

MAGIS COMBO PLUS

D.H.W. MODE

In D.H.W. operation, the condensation generator and Heat Pump work on a single boiler flow/return circuit.

At operating logic level, you can choose between 2 options on parameter I 08 from the INTEGRATION MENU:

- I 08 = Simultaneous D.H.W. = OFF (default);
- I 08 = Simultaneous D.H.W. = ON.

Leaving OFF, in case of simultaneous system and D.H.W. request, the D.H.W. has priority; only one generator works (based on outdoor temperature and time of integration) - the following example shows operation with Heat Pump (1).

This setting is suitable, for example, for high inertia ai conditioning systems (e.g. radiant panels); it also favours the energy performances of the machine, making appropriate use of the Heat Pump (1) for domestic hot water.

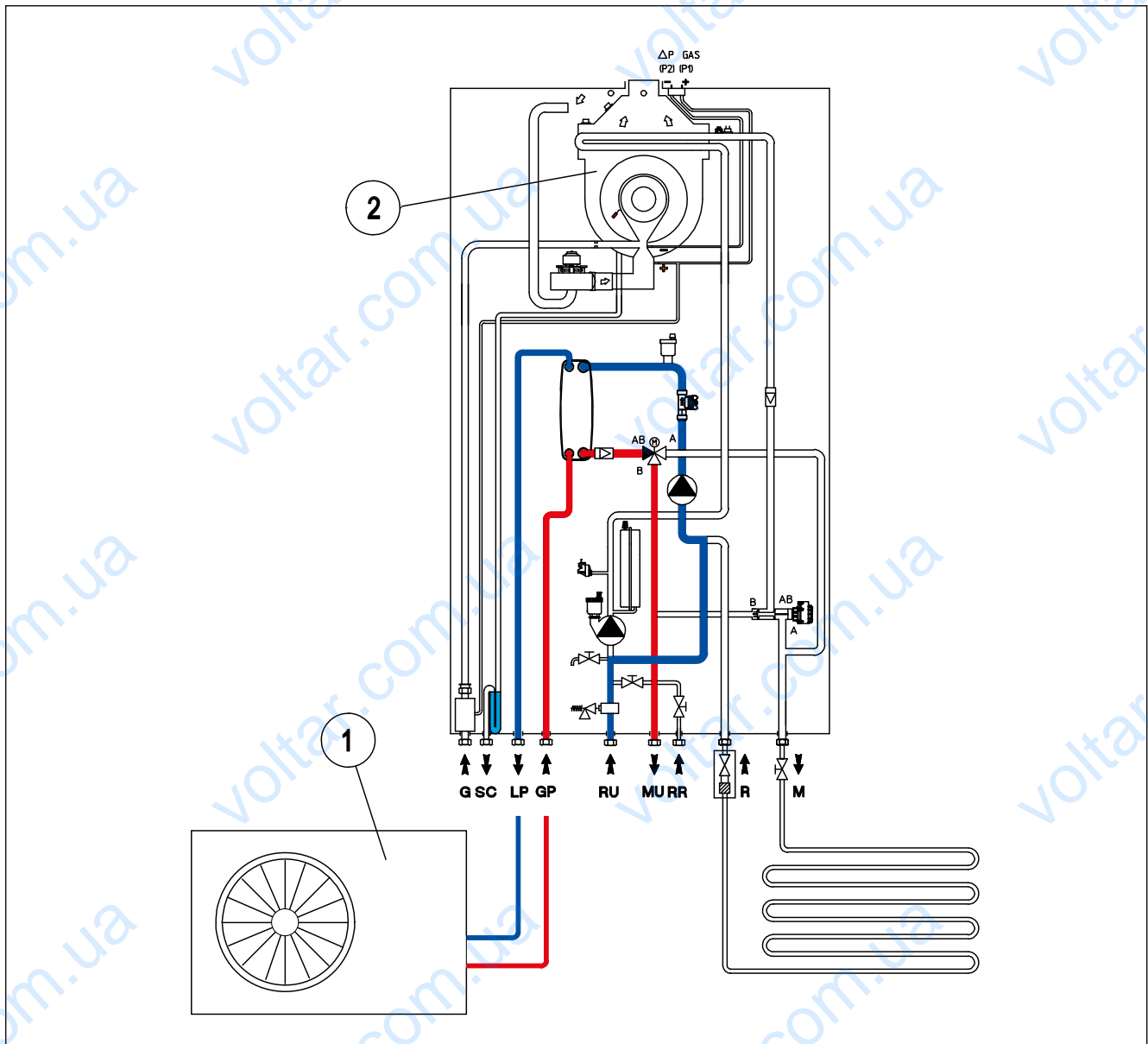

MAGIS COMBO PLUS

Whereas, by setting parameter I 08 from the INTEGRATION MENU:

I 08 = Simultaneous D.H.W. = ON, in case of simultaneous system and D.H.W. request, both requests are run together (both generators will be active).

In case of simultaneous request, this favours the operation of the condensation generator (2) for D.H.W. (the water circulates according to the following diagram).

This mode is useful, for example, with low inertia air conditioning systems (e.g. fan coils).

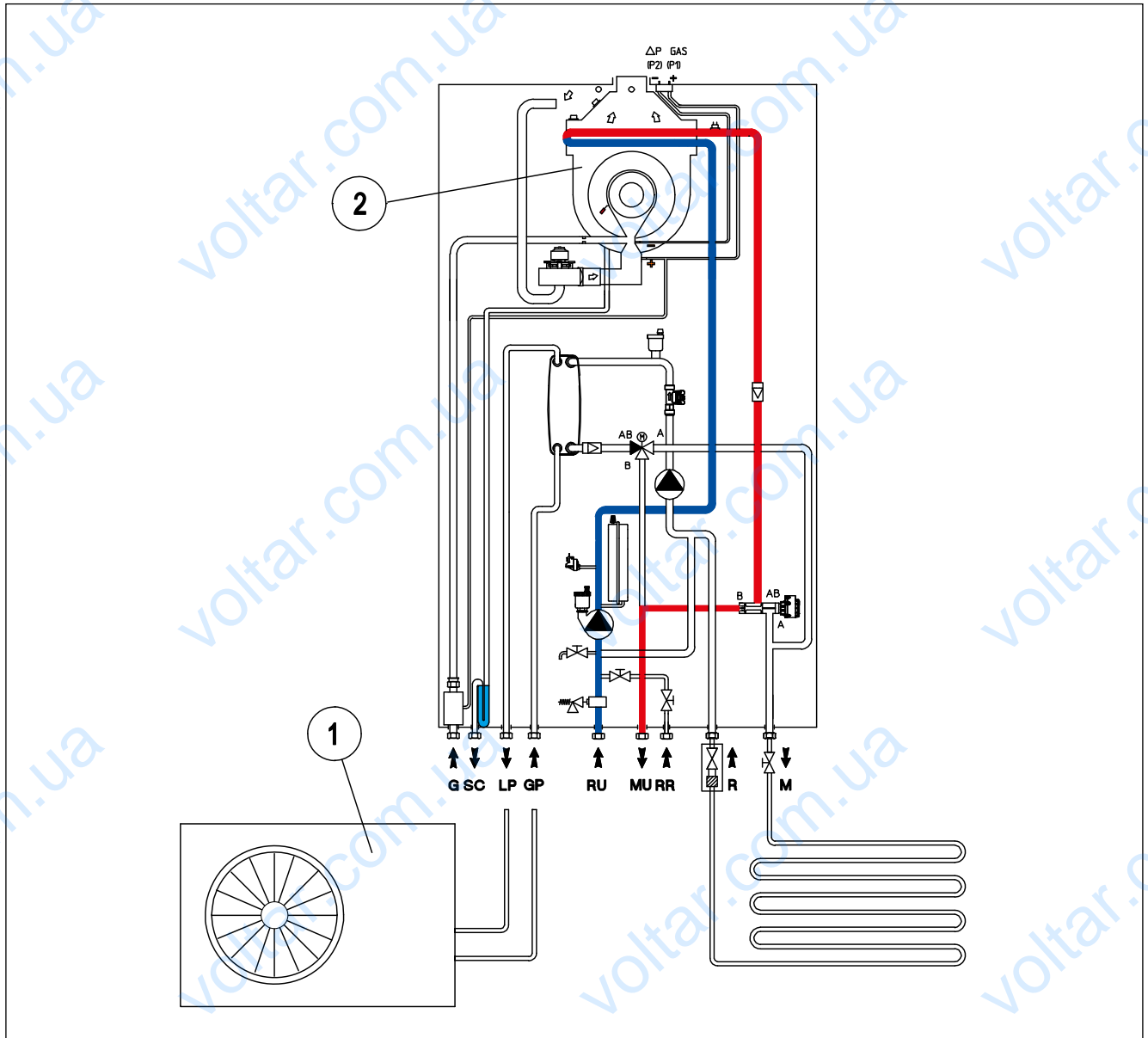

MAGIS COMBO PLUS

D.H.W. MODE + COOLING MODE

Example of operation by setting parameter I 08 from the INTEGRATION MENU:

I 08 = Simultaneous D.H.W. = ON, in the summer in cooling mode: The condensation generator (2) ensures the production of D.H.W.;

The Heat Pump (1) cools the rooms.

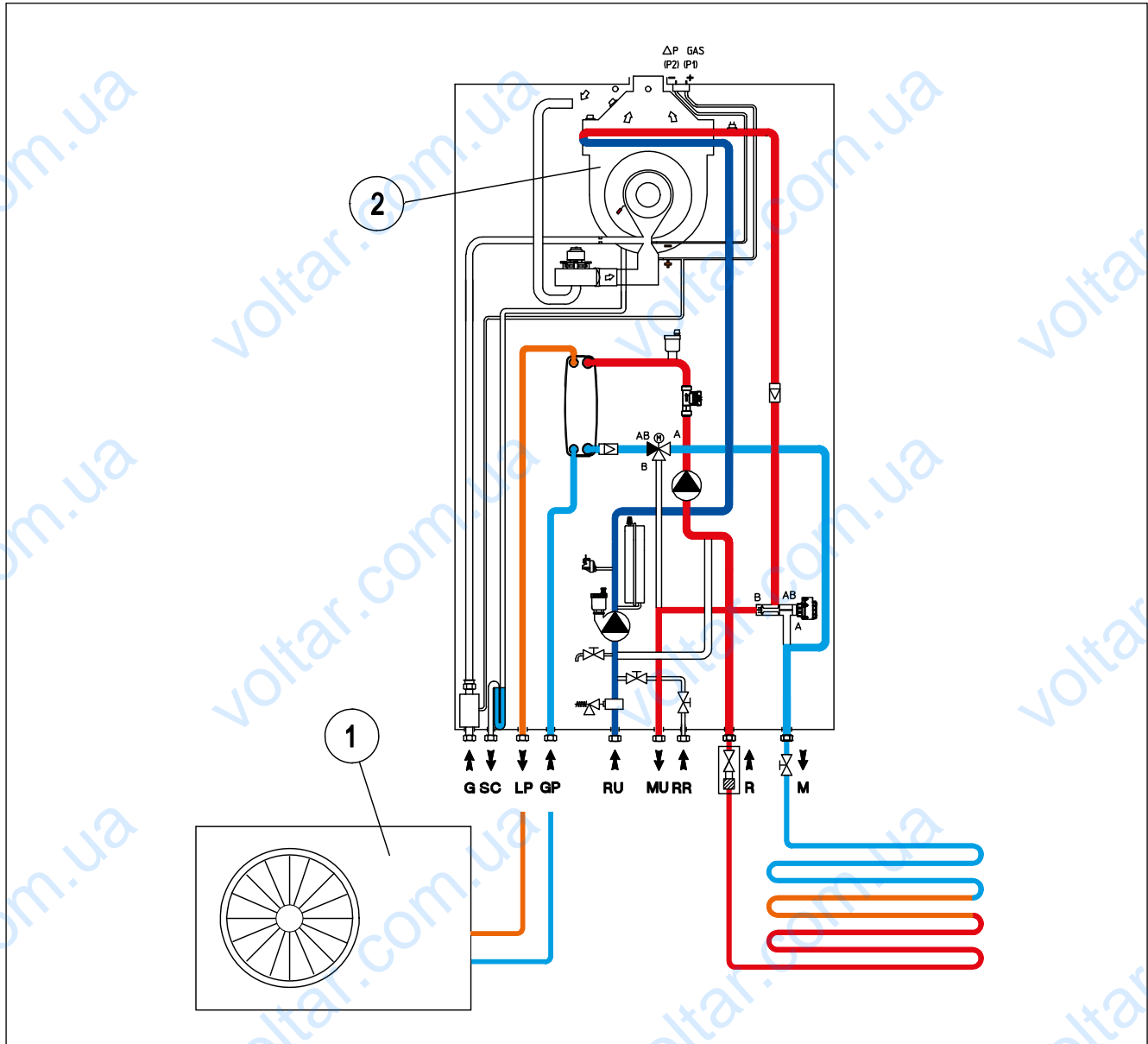

MAGIS COMBO

42

OPERATING PRINCIPLES

OPERATION IN ROOM HEATING MODE:

Following a request during the room heating mode, the electronics decide, according to the external temperature, whether to activate the heat pump, or (with cold temperatures) the condensation generator.

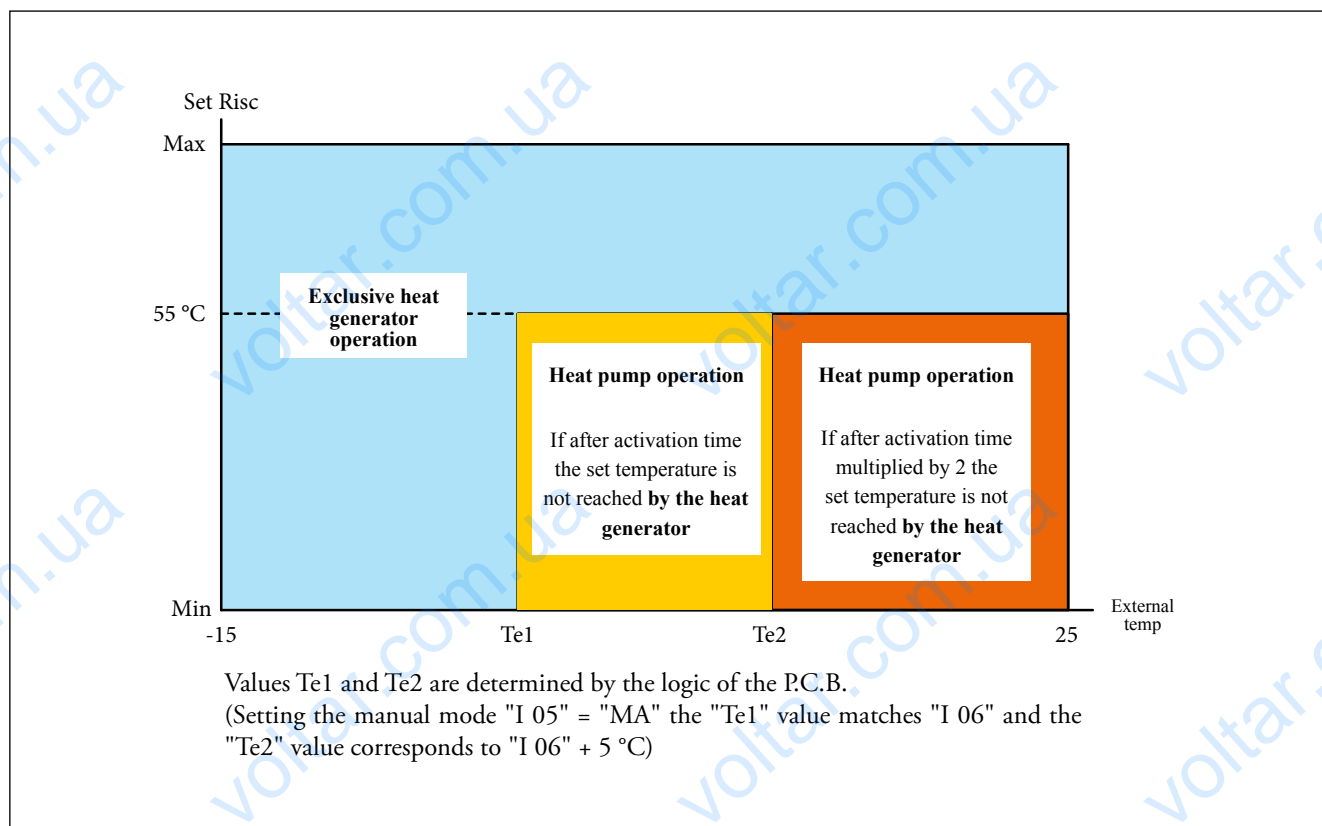

NOTE: Based on the outdoor temperature, if MAGIS COMBO requires a flow temperature higher than 55°C, the condensation generator is directly activated.

Outdoor temperatures that determine the activation logic of the generators (AUTO mode).

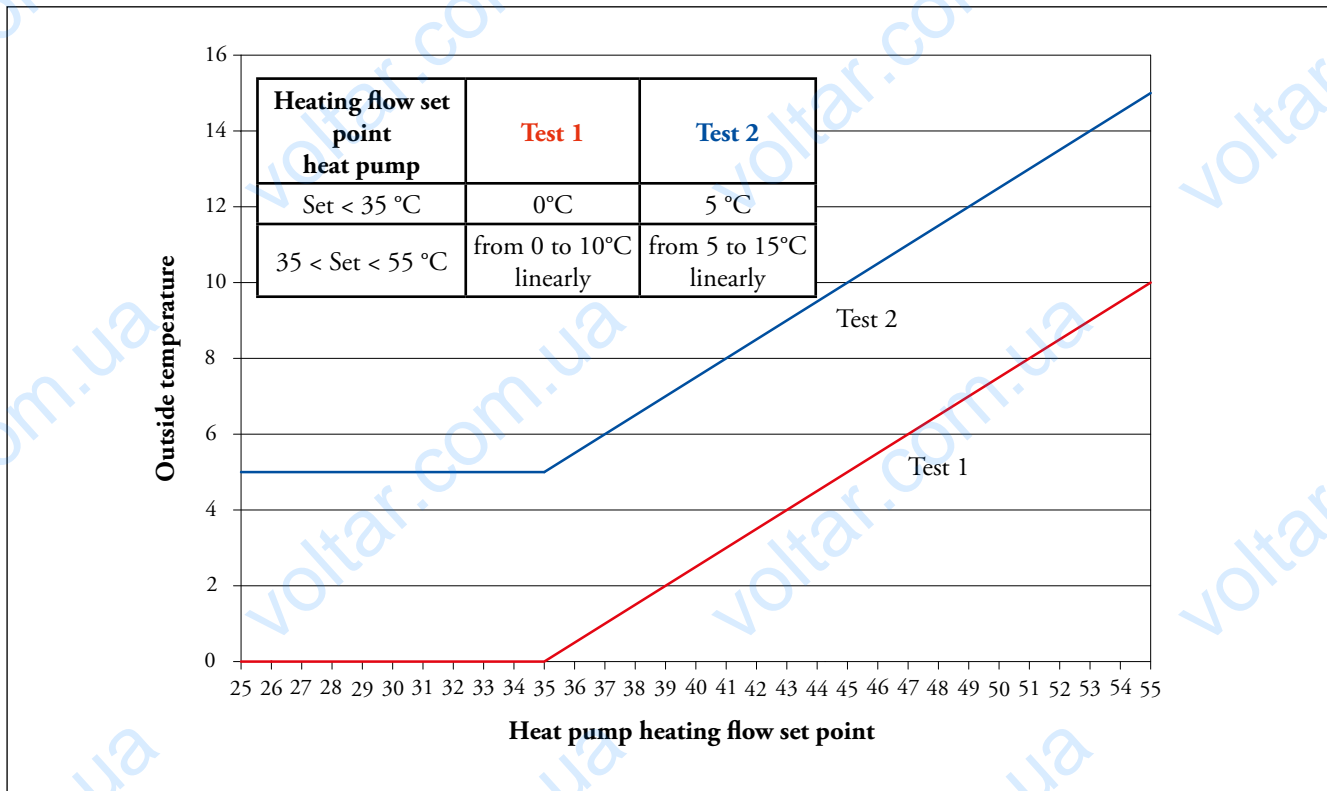

The MAGIS COMBO menu contains - among others - the INTEGRATION MENU with the following parameters:

INTEGRATION MENU			
Id	Parameter	Range	Default
I 02	System integration enabling	OFF - AL	AL
I 04	Central heating max. wait time	0 ÷ 255 minutes (1 minute steps)	45
I 05	Integration activation mode	AU - MA	AU
I 06	Manual activation temperature	-15 ÷ +20 °C	-5
I 07	Activation band	0 ÷ 10 °C	5
I 08	Simultaneous D.H.W.	OFF - ON	OFF

PAR. I 02 - System integration enabling - (settable AL - OFF, default value AL). Using this function, you can enable the condensation generator operation (A) to integrate heating system central heating.

PLEASE NOTE: With OFF Mode, always and only the Heat Pump will run, even in case of Heat Pump block, the condensation generator does NEVER activates for system integration.

PAR. I 04 - Central heating max. wait time - (settable from 0 ÷ 255 minutes, default value 45 minutes). Establishes the reference time of the activation and deactivation timing of the central heating integration.

PAR. I 05 - Integration activation mode - (AU - MA settable, default value AU). Establishes when to activate the condensation generator, in “MA” mode (manual) it is activated an a fixed external temperature and is equivalent to the value set with parameter “I 06”, in “AU” mode (automatic) the condensation generator is activated according to the operating conditions.

PAR. I 06 - Manual activation temperature - (settable from -15°C ÷ +20°C, default value -5°C). Establishes the outdoor temperature under which the central heating condensation generator is enabled.

PAR. I 07 - Activation band - (settable from -0°C ÷ +10°C, default value -5°C). It is a hysteresis that is used to establish the achievement of the heating set-point, avoiding the activation of the condensation generator.

PAR. I 08 - Simultaneous D.H.W. (settable ON - OFF, default value OFF).

Enables the simultaneous operation in D.H.W. mode and room air conditioning mode. For instant MAGIS COMBO the simultaneousness is always guaranteed regardless of what is set.

It is possible to also use MAGIC COMBO only as heat generator (if AUDAX PRO is installed at a later time), setting the “A11” parameter at OFF.

The management logic now becomes totally similar to that of a “normal” condensation generator.

MAGIS COMBO

43 INTRODUCTION WITH COMMENTARY TO THE DIAGRAMS: MAIN APPLICATIONS

44-44.1 - Diagram with MAGIS COMBO (Instant) and 2 zone kit (1 direct and 1 mixed) + Thermal Solar System

Description of winter functioning:

- CH phase active:

One or more room sensors activate the consent during the winter phase.

When operating in winter heating mode the switching logic between condensation generator and heat pump circuit can be selected between 2 options:

- 1) With variable external switching temperature according to the flow temperature ("AUTO" mode);
- 2) With fixed external switching temperature ("MANUAL" mode).

If the heat pump is unable to bring the system to temperature within a certain time, the condensation generator activates.

The logic of intelligent activation of the generators (heat pump and condensation generator) is integrated in the MAGIS COMBO electronics.

- DHW phase:

In Instant MAGIS COMBO the D.H.W. is heated by the boiler (obviously because of exchanged power).

The diagram shows the coupling of a separate storage tank unit, by connection in series: this also takes advantage of the Solar as RES, to supplement the production of D.H.W.

45-45.1 - Diagram with MAGIS COMBO PLUS and 2 zone kit (1 direct and 1 mixed) + Photovoltaic

Description of winter functioning:

- CH phase active:

One or more room sensors activate the consent during the winter phase.

When operating in winter heating mode the switching logic between condensation generator and heat pump circuit can be selected between 2 options:

- 1) With variable external switching temperature according to the flow temperature ("AUTO" mode);
- 2) With fixed external switching temperature ("MANUAL" mode).

If the heat pump is unable to bring the system to temperature within a certain time, the condensation generator activates.

The logic of intelligent activation of the generators (heat pump and condensation generator) is integrated in the MAGIS COMBO electronics.

- Domestic hot water phase:

In D.H.W. operation, condensation generator and heat pump work on a single boiler flow/return circuit.

At operating logic level, you can choose between 2 options:

- 1) SIMULTANEOUS D.H.W. = OFF (standard);
- 2) SIMULTANEOUS D.H.W. = ON.

Leaving OFF, in case of simultaneous system and D.H.W. request, the D.H.W. has priority; only one generator works (based on outdoor temperature and time of integration).

This setting is suitable for high inertia air conditioning system (e.g. radiant floor panels).

44

**HYDRAULIC DIAGRAM: MAGIS COMBO (INSTANT)
+ KIT 2 ZONES (1 DIRECT AND 1 MIXED) + THERMAL SOLAR SYSTEMS**

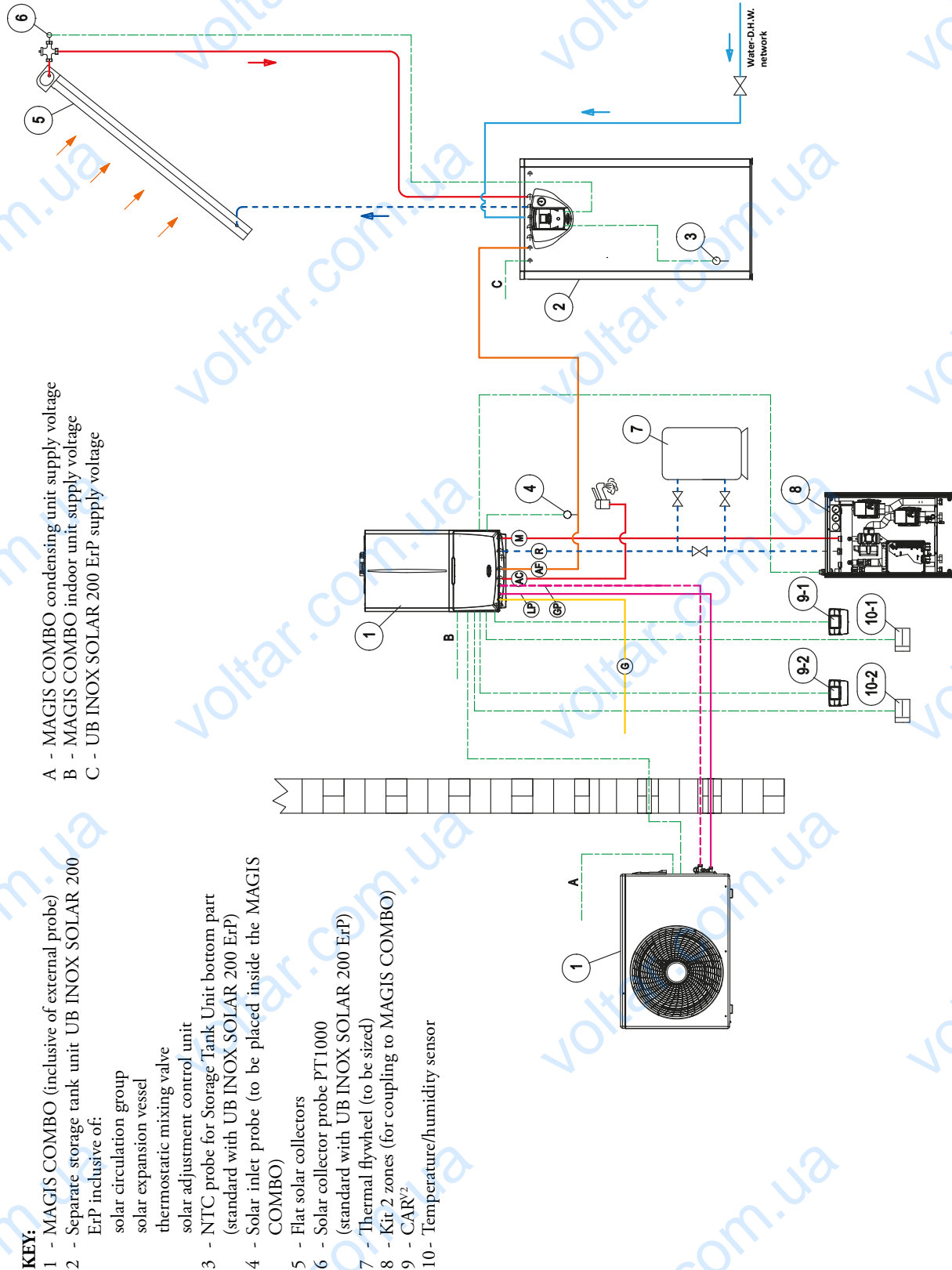

NOTE: this diagram is an example. It is also required to convey the condensate drain of the heat pump and condensation generator. In order to guarantee proper Heat Pump operation, each system must consider inserting a bypass to guarantee a minimum flow rate of 500 l/h.

MAGIS COMBO

44.1

WIRING DIAGRAM: MAGIS COMBO (INSTANT) + KIT 2 ZONES (1 DIRECT AND 1 MIXED) + THERMAL SOLAR SYSTEMS

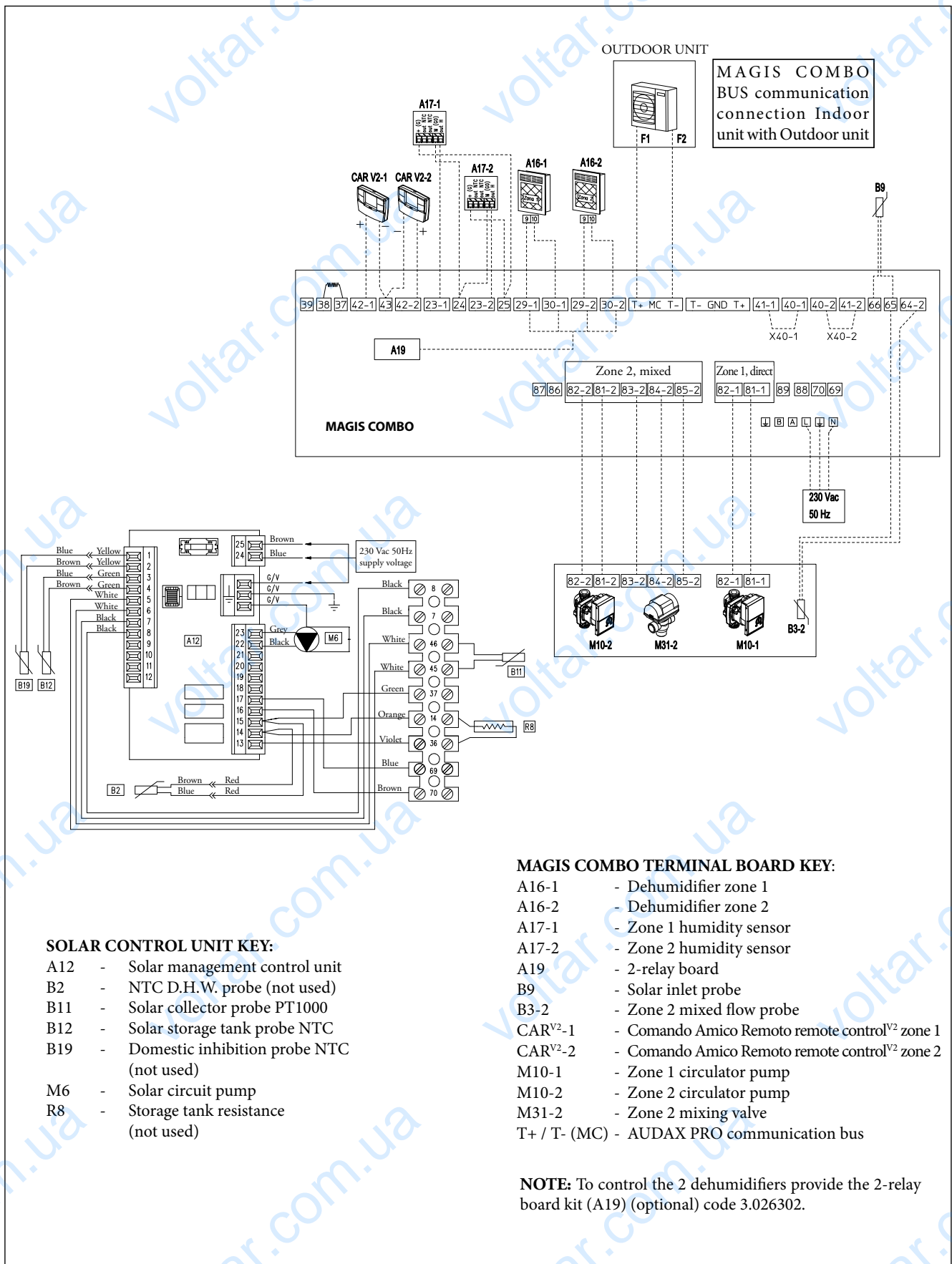

45

HYDRAULIC DIAGRAM: MAGIS COMBO PLUS + KIT 2 ZONES (1 DIRECT AND 1 MIXED) + PHOTOVOLTAIC

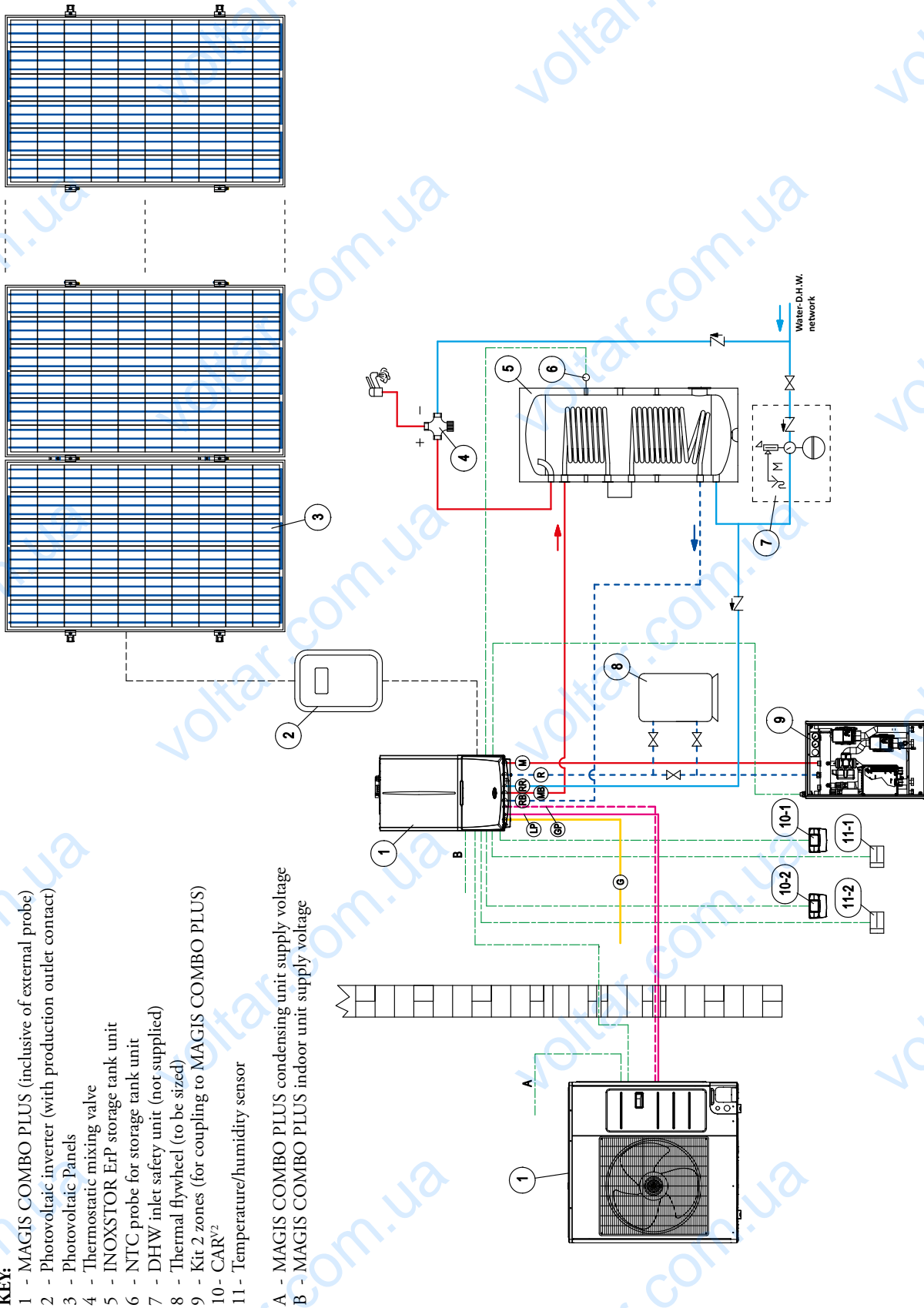

KEY:

- 1 - MAGIS COMBO PLUS (inclusive of external probe)
- 2 - Photovoltaic inverter (with production outlet contact)
- 3 - Photovoltaic Panels
- 4 - Thermostatic mixing valve
- 5 - INOXSTOR ErP storage tank unit
- 6 - NTC probe for storage tank unit
- 7 - DHW inlet safety unit (not supplied)
- 8 - Thermal flywheel (to be sized)
- 9 - Kit 2 zones (for coupling to MAGIS COMBO PLUS)
- 10- CAR²
- 11 - Temperature/humidity sensor
- A - MAGIS COMBO PLUS condensing unit supply voltage
- B - MAGIS COMBO PLUS indoor unit supply voltage

NOTE: this diagram is an example. It is also required to convey the condensate drain of the heat pump and condensation generator. In order to guarantee proper Heat Pump operation, each system must consider inserting a bypass to guarantee a minimum flow rate of 500 l/h.

MAGIS COMBO PLUS

45.1

WIRING DIAGRAM: MAGIS COMBO PLUS + KIT 2 ZONES (1 DIRECT AND 1 MIXED) + PHOTOVOLTAIC

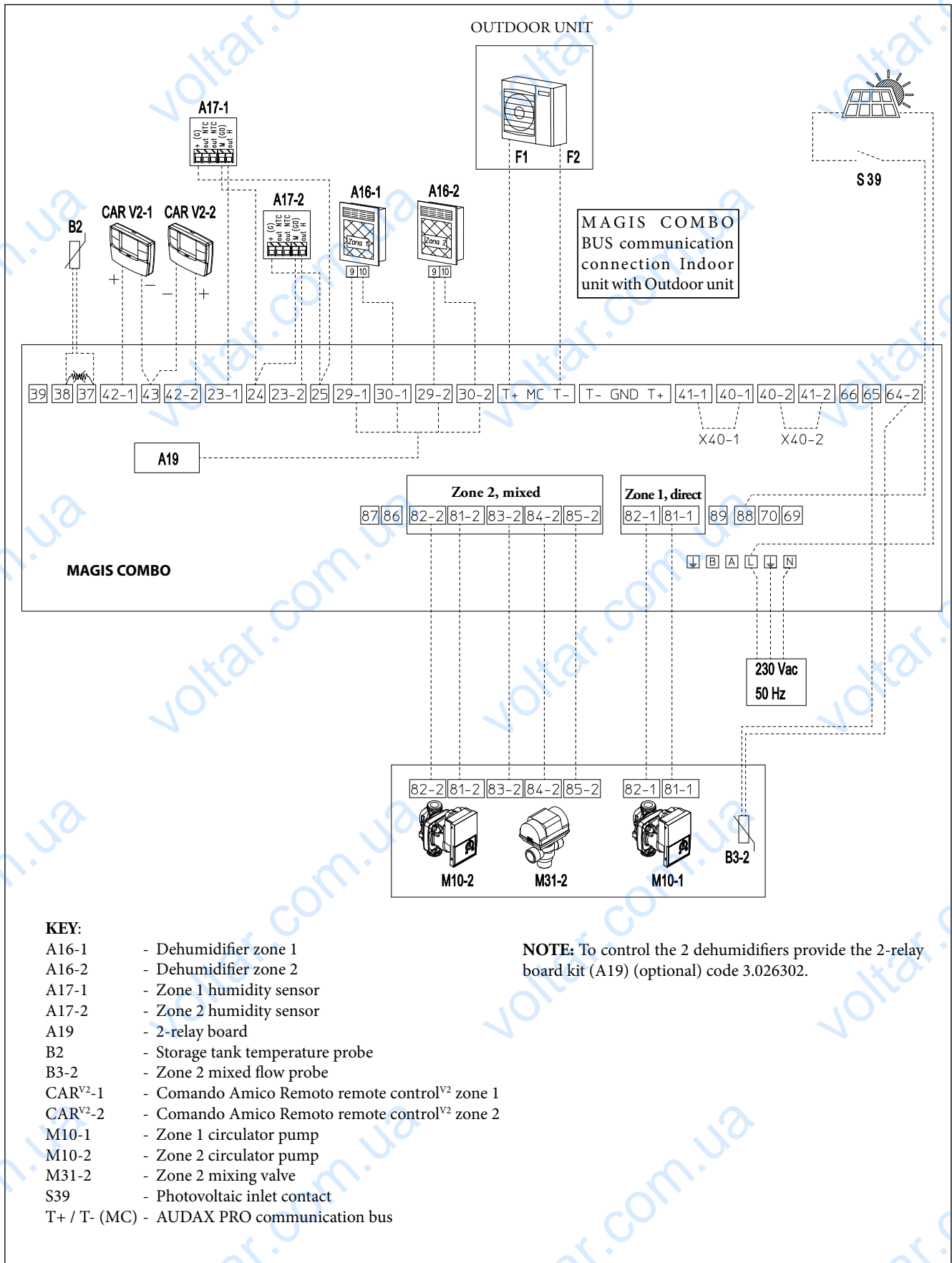

During the useful life of the products, performance is affected by external factors, e.g. the hardness of the DHW, atmospheric agents, deposits in the system and so on.

The declared data refers to new products that are correctly installed and used in accordance with applicable regulations.

N.B.: correct periodic maintenance is highly recommended.

NOTE: Depending on the specific design and installation conditions, the diagrams and drawings provided in this documentation can require further integration or modifications, according to that envisioned by the Standards and technical regulations in force and applicable (as an example, Collection R - edition 2009 is stated). It is the professional's responsibility to identify the provisions applicable, to evaluate the compatibility with these case by case and the necessity of any changes to drawings and elaborations.



Immergas TOOLBOX

The App designed by Immergas for professionals



immergas.com



To request further specific details, sector Professionals can also use the following e-mail address:

consulenza@immergas.com

Immergas S.p.A.
42041 Brescello (RE) - Italy
Tel. 0522.689011
Fax 0522.680617



IMMERGAS
UNI EN ISO 9001:2008
CERTIFIED QUALITY
SYSTEM

Design, manufacture and after-sales assistance of gas boilers, gas water heaters and relative accessories

