

# PRESSURE REDUCING VALVES



## MAIN FEATURES

The pressure reducing valve is able, by varying its pressure drops, to hold the downstream pressure of the fluid at a constant level against changes in the upstream pressure and flow rate. The pressure reducing valve is used:

- in water/plumbing systems: to hold a constant water pressure in the water supply main after the pressure reducing valve;
- in plumbing systems/sanitary appliances: to maintain the water pressure constantly below the max. permissible value;
- in water/plumbing systems: to save water. By controlling the pressure to the taps, excessive withdrawal of water from the taps is avoided;
- in compressed air systems: to keep the air pressure constant in the main, regardless of fluctuations in pressure supplied by the compressors;
- after tanks or storage cylinders: to reduce and stabilize the pressure in the main, which is normally lower.

## GENERAL

The WATTS Cazzaniga pressure reducing valves **Series DRV, DRVN and DRVD** are of balanced seat type.

This means that the inlet pressure, when acting on the two openings A and B with the same section, is compensated. Therefore it does not exert any force on the pin-plug system when the degree of valve opening changes.

Instead, the outlet pressure acts on the diaphragm and hence on the pin-plug system which, therefore, is subjected to two opposing forces, namely: the force exerted by the outlet pressure tending to close the plug, and the pressure exerted by the spring tending to open it.

This results in the pressure reducing valve acting like a balanced seat type having the outlet pressure almost unaffected by variations in upstream pressure.

## SETTING

The difference between the downstream pressure P2 measured with zero flow rate and the same pressure measured with a general flow rate Q represents the pressure drop DP across the pressure reducing valve. It depends on the flow rate as shown in the pressure drop diagrams.

If it is required for the upstream pressure not to exceed a given value P2, this should be adjusted to value P2 when the flow rate is zero. At flow rate Q, the downstream pressure will be below the value P2 by an amount equal to pressure drops DP.

When the pressure reducing valve is installed to ensure that the downstream pressure reaches a given value P2 at a certain flow rate Q, this pressure should be adjusted to value P2 + DP when the flow rate is zero. At flow rate Q the downstream pressure will be equal to P2.

## SIZING

The valve selection criterion consists in determining the diameter so that the speed of the fluid does not reach excessive levels, at nominal flow rate, thus causing excessive pressure drops and noisy effluent which are transmitted to the supply main. The flow rate-speed diagrams provide a guide for selecting the valve diameter in the case of liquids (see water) or gases with pressures of 8 to 10 bar (see air).

## EXAMPLES OF SIZING

### Example 1 (cavitation)

Pressure reducing valve with:

Inlet pressure P1 = 14 bar

Outlet pressure P2 = 3 bar

From the cavitation diagram it can be seen that the pressure reducing valve works constantly in the red zone. To avoid rapid deterioration, two valves can be used, one connected upstream to the other.

Upstream valve: pressure change from 14 to 6 bar (green zone)

Downstream valve: pressure change from 6 to 3 bar (green zone).

### Example 2 (flow rate)

Pressure reducing valve DRV/N with:

Inlet pressure (min.) P1 = 8 bar

Outlet pressure P2 = 4 bar

Max. flow rate Q = 50 l/min

From the flow rate-speed diagram it can be seen that a diameter of 20 or 25 can be used. The pressure drop diagram shows that in the two cases:

DRV20/N Q = 50 l/min DP = 1.1 bar

DRV25/N Q = 50 l/min DP = 0.68 bar



### DRV

Diaphragm pressure reducing valve with single balanced seat. Ensures min. pressure drops with high flow rates. Downstream pressure set by means of the setting screw (4) and is locked with lock nut (3)

### Part No.

### SIZE

0501115	1/2"MM
0501120	3/4"MM
0501125	1"MM
0501132	1.1/4"MM
0501140	1.1/2"MM
0501150	2"MM



### DRVN

Like DRV, but with pressure gauge Ø50 for reading downstream pressure

### Part No.

### SIZE

0501315	1/2"MM
0501320	3/4"MM
0501325	1"MM
0501332	1.1/4"MM
0501340	1.1/2"MM
0501350	2"MM

Flow rate/speed diagram DRV - DRVN

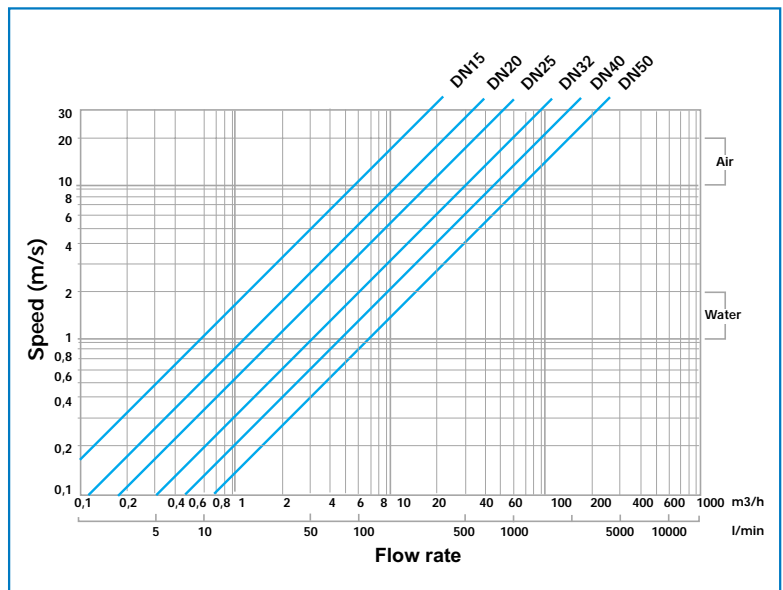

Flow rate/speed diagram DRVD

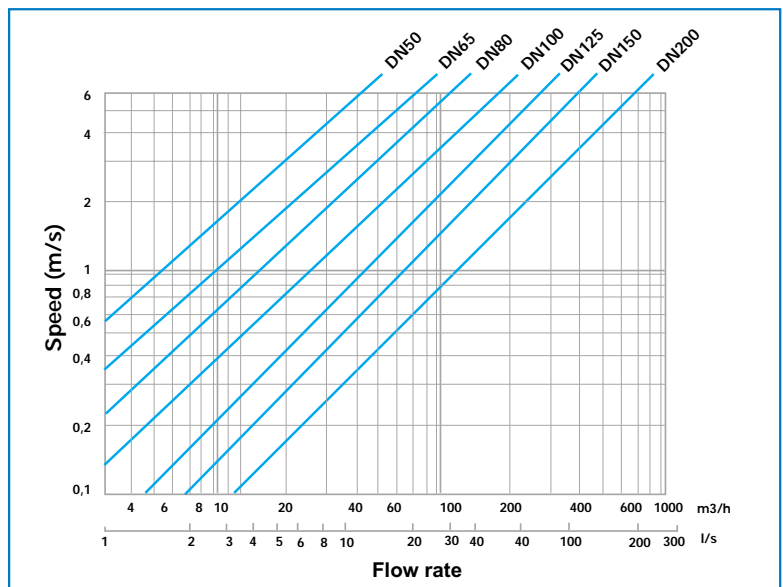

## CAVITATION

The cavitation diagram shows three zones of valve operation in relation to the upstream and downstream pressures, namely:

zone C: normal duty, no cavitation

zone B: medium duty, possible cavitation

zone A: heavy duty, the valve cavitates.

Continuous operation in the red cavitation zone causes rapid deterioration of the internal parts. If the pressure reducing valve is to be used in the red zone, please contact the WATTS Cazzaniga Engineering Department.

## APPLICATION

Water, air and neutral (non aggressive) gases.

## APPROVALS

- DVGW approval (Arbeitsblatt W 375)
- LGA approval (DVR15 to 32) according to DIN 4109 class I (noise below 20 dB)
- SVGW approval (W/TPW101).
- TIN approval (Poland)
- CSTB approval (NF P 43-006) (DRV15, DRV20).
- KTW certification for all materials in contact with water.

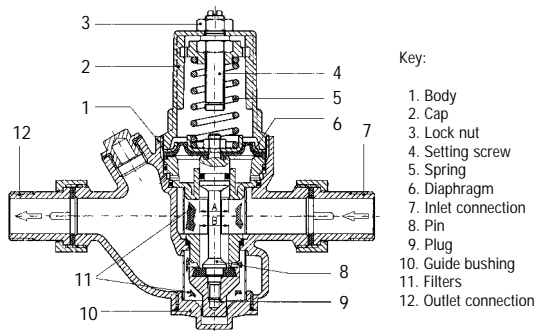

## Overall dimensions (mm)

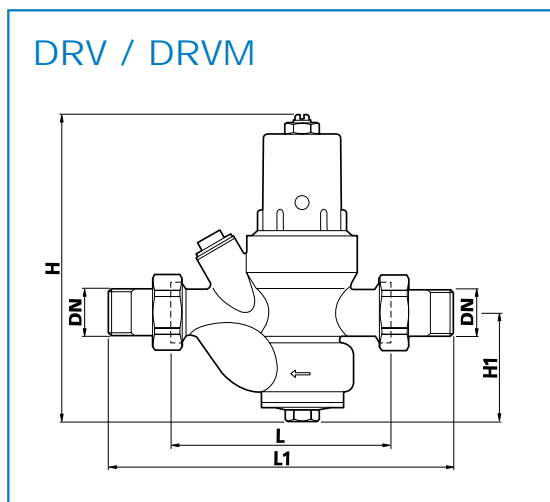

### DRV / DRVM

SIZE	L	L1	H	H1
1/2"	97	152	135	48
3/4"	110	171	155	58
1"	120	191	182	66
1.1/4"	140	211	227	75
1.1/2"	160	246	255	82
2"	175	261	262	88

## Cavitation diagram

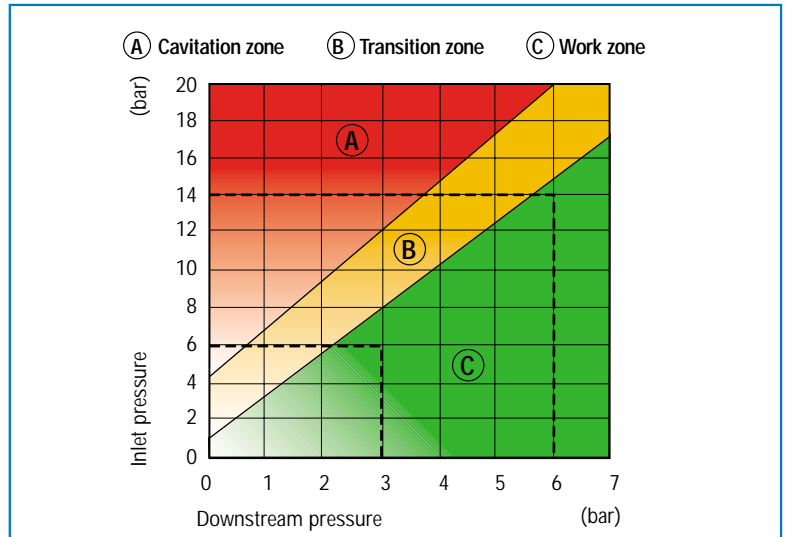

## TECHNICAL CHARACTERISTICS

Max. upstream pressure	25 bar
Downstream pressure (outlet)	1.5 to 6 bar
Connections	to M / M tailpiece
Downstream pressure adjustment (screw 4)	Clockwise rotation: increase in pressure Anti-clockwise pressure: decrease in pressure
Downstream pressure gauge (DRV-M only)	Pressure gauge Ø50, scale 0 to 6 bar
Max. operating temperature	70° C

## DESIGN FEATURES

Body	Shot-blasted brass OT58
Cap	Shot-blasted brass OT58
Plug	Brass OT58
Inlet / outlet connections	Brass OT58
Diaphragm	NBR with nylon fabric
Seal and O-ring	NBR
Spring	Galvanized steel
Setting screw and lock nut	Brass OT58
Filters	Stainless steel

## Flow rate - Pressure drop diagram

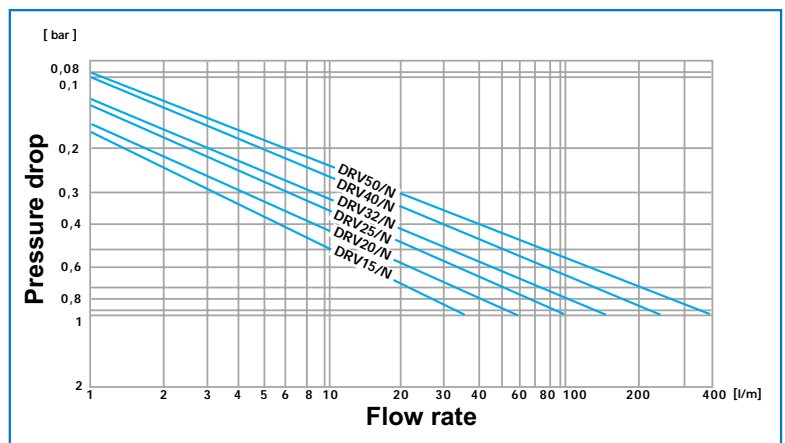

## APPLICATION

Water, air and neutral (non aggressive) gases.

## APPROVALS

- DVGW approval (Arbeitsblatt W 375)
- LGA approval (DRV15/N to DRV32/N) according to DIN 4109 class I (noise below 20 dB)
- CSTB approval (NF P 43-006) (DRV15/N, DRV20/N).
- KTW certification for all materials in contact with water

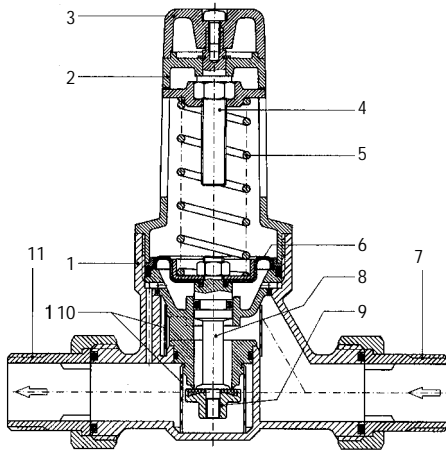

Key:

1. Body
2. Cap
3. Adjusting knob
4. Settling screw
5. Spring
6. Diaphragm
7. Inlet connection
8. Pin
9. Plug
10. Filters
11. Outlet connection

## Overall dimensions (mm)

### DRVN / DRVMN

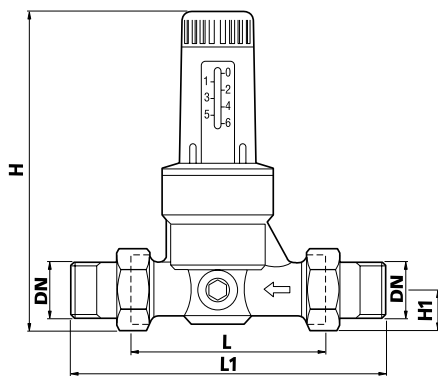

SIZE	L	L1	H	H1
1/2"	97	152	135	48
3/4"	110	171	155	58
1"	120	191	182	66
1.1/4"	140	211	227	75
1.1/2"	160	246	255	82
2"	175	261	262	88



### DRVN

Diaphragm pressure reducing valve with single balanced seat. Ensures min. pressure drops with high flow rates. Downstream pressure set by means of knob (3) with adjustment scale 1 to 6 bar.

### Part No.

### SIZE

0502515	1/2"MM
0502520	3/4"MM
0502525	1"MM
0502532	1.1/4"MM
0502540	1.1/2"MM
0502550	2"MM



### DRVMN

Like DRVN, but with pressure gauge Ø50 for reading downstream pressure.

### Part No.

### SIZE

0502615	1/2"MM
0502620	3/4"MM
0502625	1"MM
0502632	1.1/4"MM
0502640	1.1/2"MM
0502650	2"MM

## DESIGN FEATURES

Body	Shot-blasted brass OT58
Cap	Reinforced plastic
Plug	Brass OT58
Inlet / outlet connections	Brass OT58
Diaphragm	NBR with nylon fabric
Seal and O-ring	NBR
Spring	Galvanized steel
Setting screw	Brass OT58
Filters	Stainless steel

## TECHNICAL CHARACTERISTICS

Max. upstream pressure	25 bar
Downstream pressure (outlet)	1.5 to 6 bar
Connections	to M / M tailpiece
Downstream pressure adjustment (knob 3)	Clockwise rotation: increase in pressure Anti-clockwise pressure: decrease in pressure
Downstream pressure gauge (DRV-MN only)	Pressure gauge Ø 50, scale 0 to 6 bar
Max. operating temperature	80° C

## Flow rate - Pressure drop diagram

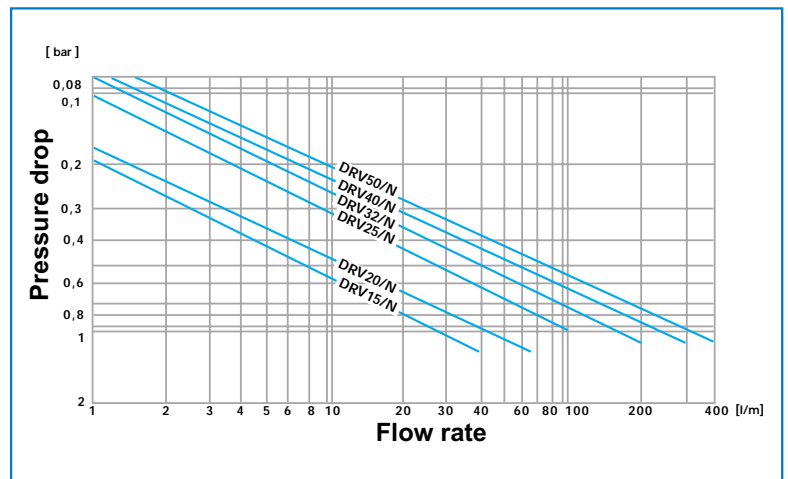

## APPLICATION

Water, air and neutral (non aggressive) gases.

## APPROVALS

- ASSE, ANSI, CSA, UPC (USA) approvals
- WATTS Patent, U.S. Patent N° 3. 115. 154

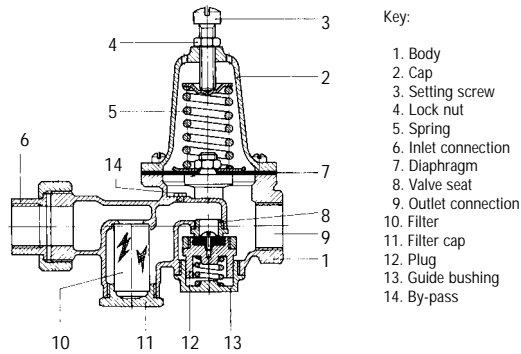

### WATTS Patent, U.S. Patent N° 3. 115. 154

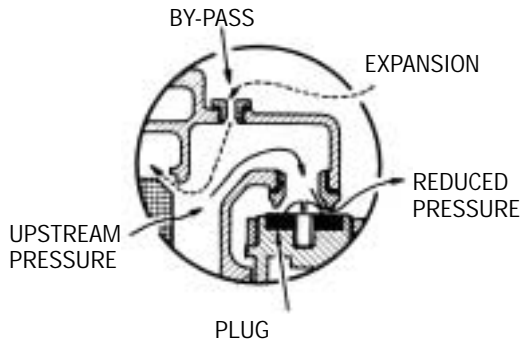

### Overall dimensions (mm)

#### U5B

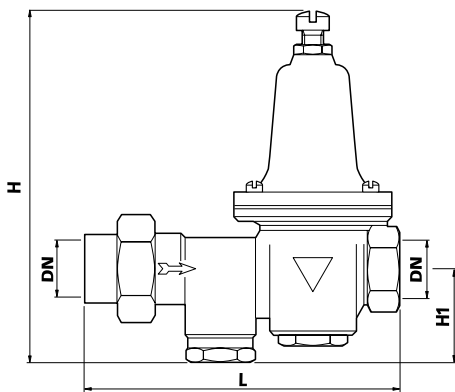

SIZE	L	H	H1
1/2"	146	175	48
3/4"	162	184	48
1"	171	203	51
1.1/4"	203	213	57
1.1/2"	241	248	76
2"	279	311	83



#### U5B

(WATTS Patent, U.S. Patent N° 3. 115. 154)

Diaphragm pressure reducing valve, single seated, with spring. Ensures min. pressure drops with high flow rates. Provided with upstream filter having ample surface and separate connection for easy cleaning. Downstream pressure set by means of screw (3). Fitted with by-pass valve, it allows freeing on the upstream main any overpressure at downstream side (generated, for example, by expansion of water in the water heaters).

#### Part No.

#### SIZE

1506115	1/2" FF
1506120	3/4" FF
1506125	1" FF
1506132	1.1/4" FF
1506140	1.1/2" FF
1506150	2" FF

### DESIGN FEATURES

Body	Bronze
Cap	Cast iron
Plug	Stainless steel
Inlet connection	Bronze
Diaphragm	Nordel with nylon fabric
Seal and O-ring	NBR
Spring	Galvanized steel
Setting screw and lock nut	Galvanized steel
Filters	Stainless steel

### TECHNICAL CHARACTERISTICS

Max. upstream pressure	20 bar
Downstream pressure (outlet)	Adjustable 1.5 to 5 bar
Upstream connection	to F threaded tailpiece
Downstream connection	F threaded
Downstream pressure adjustment (screw 3)	Clockwise rotation: increase in pressure Anti-clockwise pressure: decrease in pressure
Max. operating temperature	80° C

### Flow rate - Pressure drop diagram

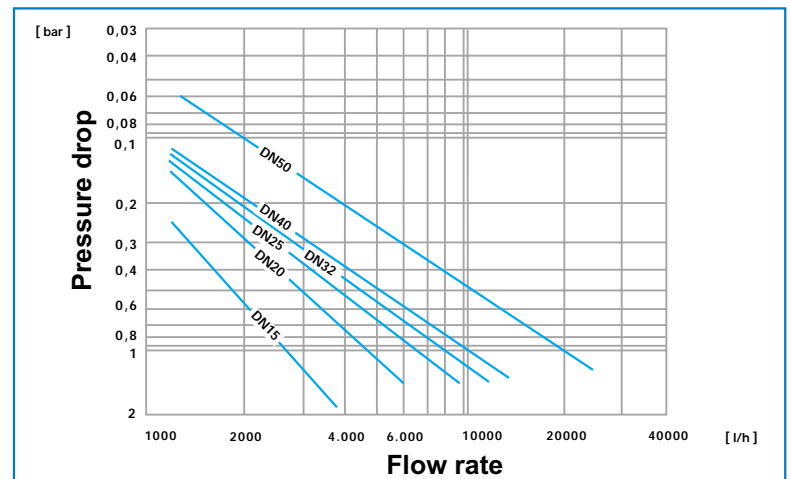



## APPLICATION

Water, air and neutral (non aggressive) gases.



### DRVD16

Flanged pressure reducing valve with single balanced seat and spring. Ensures min. pressure drops with high flow rates. Downstream pressure set by means of screw (9). Nodular cast iron body faced with epoxy resins.



### DRVD25

Like DRVD16 but with max. inlet pressure: 25 bar.



### DRVD40

Like DRVD16 but with max. inlet pressure: 40 bar.

#### PN: 16 bar

##### Pout: 1.5-6 bar

0504053	DRVD50/16	2"	DN50
0504068	DRVD65/16	2 <sup>1/2</sup> "	DN65
0504083	DRVD80/16	3"	DN80
0504103	DRVD100/16	4"	DN100
0504128	DRVD125/16	5"	DN125
0504153	DRVD150/16	6"	DN150
0504203	DRVD200/16	8"	DN200

##### Pout: 2-8 bar

0504054	DRVD50/16/2-8	2"	DN50
0504069	DRVD65/16/2-8	2 <sup>1/2</sup> "	DN65
0504084	DRVD80/16/2-8	3"	DN80
0504104	DRVD100/16/2-8	4"	DN100
0504129	DRVD125/16/2-8	5"	DN125
0504154	DRVD150/16/2-8	6"	DN150
0504204	DRVD200/16/2-8	8"	DN200

##### Pout: 4-12 bar

0504055	DRVD50/16/4-12	2"	DN50
0504070	DRVD65/16/4-12	2 <sup>1/2</sup> "	DN65
0504085	DRVD80/16/4-12	3"	DN80
0504105	DRVD100/16/4-12	4"	DN100
0504130	DRVD125/16/4-12	5"	DN125
0504155	DRVD150/16/4-12	6"	DN150
0504205	DRVD200/16/4-12	8"	DN200

#### PN: 25 bar

##### Pout: 1.5-6 bar

0504050	DRVD50/25	2"	DN50
0504065	DRVD65/25	2 <sup>1/2</sup> "	DN65
0504080	DRVD80/25	3"	DN80
0504100	DRVD100/25	4"	DN100
0504125	DRVD125/25	5"	DN125
0504150	DRVD150/25	6"	DN150
0504200	DRVD200/25	8"	DN200

##### Pout: 2-8 bar

0504051	DRVD50/25/2-8	2"	DN50
0504066	DRVD65/25/2-8	2 <sup>1/2</sup> "	DN65
0504081	DRVD80/25/2-8	3"	DN80
0504101	DRVD100/25/2-8	4"	DN100
0504126	DRVD125/25/2-8	5"	DN125
0504151	DRVD150/25/2-8	6"	DN150
0504201	DRVD200/25/2-8	8"	DN200

##### Pout: 4-12 bar

0504052	DRVD50/25/4-12	2"	DN50
0504067	DRVD65/25/4-12	2 <sup>1/2</sup> "	DN65
0504082	DRVD80/25/4-12	3"	DN80
0504102	DRVD100/25/4-12	4"	DN100
0504127	DRVD125/25/4-12	5"	DN125
0504152	DRVD150/25/4-12	6"	DN150
0504202	DRVD200/25/4-12	8"	DN200

#### PN: 40 bar

##### Pout: 1.5-6 bar

0504056	DRVD50/40	2"	DN50
0504071	DRVD65/40	2 <sup>1/2</sup> "	DN65
0504086	DRVD80/40	3"	DN80
0504106	DRVD100/40	4"	DN100
0504131	DRVD125/40	5"	DN125
0504156	DRVD150/40	6"	DN150

##### Pout: 2-8 bar

0504057	DRVD50/40/2-8	2"	DN50
0504072	DRVD65/40/2-8	2 <sup>1/2</sup> "	DN65
0504087	DRVD80/40/2-8	3"	DN80
0504107	DRVD100/40/2-8	4"	DN100
0504132	DRVD125/40/2-8	5"	DN125
0504157	DRVD150/40/2-8	6"	DN150

##### Pout: 4-12 bar

0504058	DRVD50/40/4-12	2"	DN50
0504073	DRVD65/40/4-12	2 <sup>1/2</sup> "	DN65
0504088	DRVD80/40/4-12	3"	DN80
0504108	DRVD100/40/4-12	4"	DN100
0504133	DRVD125/40/4-12	5"	DN125
0504158	DRVD150/40/4-12	6"	DN150

## DESIGN FEATURES

Body	Nodular cast iron GS400-15
Cap	Nodular cast iron GS400-15
Plug (ND 50 to 100) (ND 125 to 200)	Brass Galvanized steel
Seal	NBR
Lip seal	NBR
Seal ring	Bronze
Guide bushings	Bronze
Spring	Faced steel
Setting screw and lock nut	Galvanized steel
Finish	Epoxy resins (blue RAL 5017)

## TECHNICAL CHARACTERISTICS

Max. upstream pressure	16 - 25 - 40 bar (ND200 only up to 25 bar)
Downstream pressure (outlet)	1.5 to 6 bar (standard) 2 to 8 bar (optional) 4 to 12 bar (optional)
Downstream pressure adjustment	Clockwise rotation: increase in pressure Anti-clockwise pressure: decrease in pressure
Connections	Flanged according to UNI2223 (NP16 - 25 - 40) ND200 only NP16 and NP25
Pressure gauge connections (upstream and downstream)	G 1/4 " ND50 to ND65 G 3/8" ND80 to ND200
Max. operating temperature	80° C

## Overall dimensions (mm)

## Flow rate - Pressure drop diagram

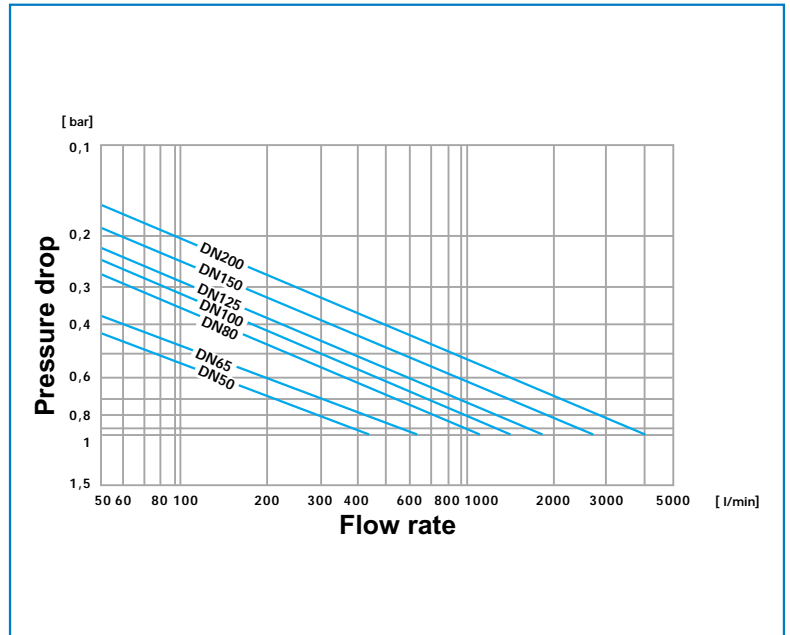
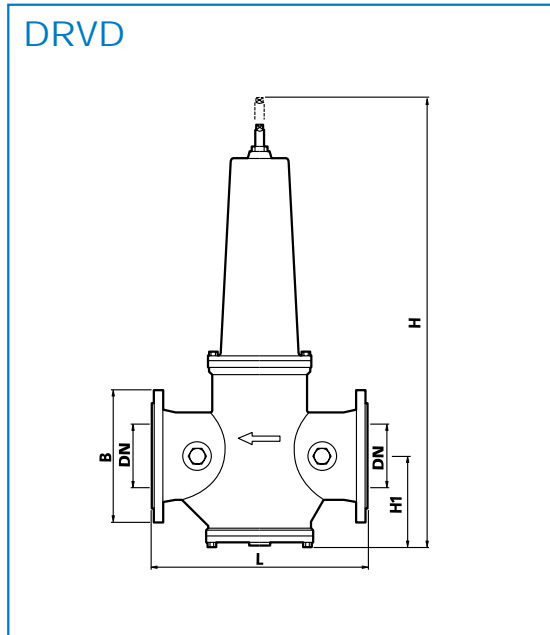

SIZE	L	H	H1	B PN16	B PN25	B PN40
50	230	383	83	165	165	165
65	290	440	90	185	185	185
80	310	490	100	200	200	200
100	350	561	121	220	235	235
125	400	712	152	250	270	270
150	450	839	169	285	300	300
200	550	1684	234	340	360	--

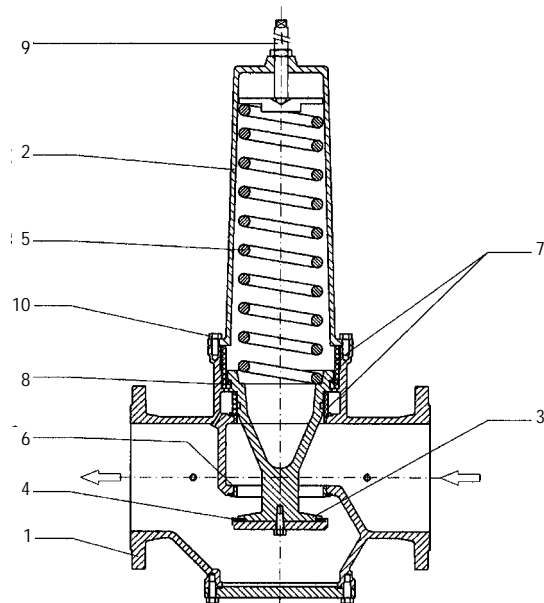

Key:

1. Body
2. Cap
3. Plug
4. Seal
5. Spring
6. Seal ring
7. Guide bushings
8. Lip seal
9. Setting screw
10. Cap screws