

Controller PCSol 300



FOR SOLAR COLLECTORS



www.econet24.com



QUALITY INTERNATIONAL
FORUM JAKOŚCI 2008

ISO 9001 ISO 14001 OHSAS 18001

pt1000	PUMP SOL	PUMP ROTATION CONTROL	PUMP	CIRCULATION	CIRCULATION PROGRAM	HEATER SUPPORT
HEATER PROGRAM	SIMPLE IN USE	INTELLIGENT ALARM	CLOCK	CLOCK SUSTAIN	TEMPORARY POWER	HEAD OUTPUT
ANTI-FREEZING	NIGHT COOLING	GRAPHIC DISPLAY	HEAT DISCHARGE	POOL		
TANK PROTECTION	TWO COMPASS DIRECTIONS	VACUUM COLLECTOR	INTERNET			



INSTALLATION AND OPERATION MANUAL

62.X.2	
REVISION	SOFTWARE

2014-05-07

CONTENTS

1. SAFE INSTALLATION AND USE	4
2. GENERAL	5
3. DIRECTIVE WEEE 2002/96/EC	5
4. DOCUMENT KEEPING	5
OPERATING MANUAL	7
5. OPERATION	8
6. CONTROLLER MENU	8
7. SETTINGS MENU	10
7. SETTINGS MENU	10
8. TIME PROGRAMS	10
8.1. TDHWMIN	10
8.2. CIRCULATION	11
9. MENU ALARMS	11
10. OPTIONS MENU	13
10.1. RESTORING FACTORY SETTINGS	13
10.2. READING DEFAULT SETTINGS.....	13
10.3. CLEARING HEAT OUTPUT DATA.....	13
11. OPERATION MANU	13
11.1. OPERATION\SETTINGS MENU	13
11.2. OPERATION\LOUDNESS MENU	14
11.3. OPERATION\CLOCK MENU	14
12. HEAT OUTPUT	15
13. SOLAR APPLICATIONS	16
13.1. NIGHT COOLING	16
13.2. SOLAR THERMAL SCHEME A.....	16
13.3. SOLAR THERMAL SCHEME B.....	17
13.4. SOLAR THERMAL SCHEME C	17
13.5. SOLAR THERMAL SCHEME D	18
13.6. SOLAR THERMAL SCHEME E.....	19
13.7. SOLAR THERMAL SCHEME F.....	19
13.8. SOLAR THERMAL SCHEME G	20
13.9. SOLAR THERMAL SCHEME H	21
13.10. SOLAR THERMAL SCHEME I	21
13.11. SOLAR THERMAL SCHEME J	22
13.12. SOLAR THERMAL SCHEME K	23
13.13. SOLAR THERMAL SCHEME L.....	23
14. SHUT DOWN	24
15. ACCESS TO THE UNIT OVER THE INTERNET	25
15.1. BASIC DATA READING.....	25
15.2. DIAGRAM OF ACTIVE SOLAR CIRCUIT SYSTEM	25
15.3. USER PARAMETERS	26
15.4. SERVICE PARAMETERS	26
15.5. HEAT YIELD GRAPH	27
15.6. NETWORK SETTINGS.....	27
INSTALLATION MANUAL	29
16. TECHNICAL DATA	30
16.1. ELEMENTS OF THE SET	30
17. INSTALLATION OF PCSOL 300	30
17.1. INSTALLATION OF THE CONTROLLER ..	30
17.2. EXTERNAL CIRCUITS CONNECTION.	32
17.2.1. Use of connectors	32
17.2.2. Power supply connection	33
17.2.3. Temperature sensor connection	33
17.2.4. Temperature sensor installation	34
17.2.5. Output H connection	34
17.2.1. ecoNET internet module connection	36
18. APPLICATION SCHEMES	37
18.1. SOLAR APPLICATION SCHEME A.....	37
18.2. SOLAR APPLICATION SCHEME B.....	38
18.3. SOLAR APPLICATION SCHEME C.....	39
18.4. SOLAR APPLICATION SCHEME D	40
18.5. SOLAR APPLICATION SCHEME E.....	41
18.6. SOLAR APPLICATION SCHEME F	42
18.7. SOLAR APPLICATION SCHEME G	43
18.8. SOLAR APPLICATION SCHEME H	44
18.9. SOLAR APPLICATION SCHEME I	45
18.10. SOLAR APPLICATION SCHEME J	46
18.11. SOLAR APPLICATION SCHEME K.....	47
18.12. APLIKACJA SCHEMAT SOLARNY L.....	48
19. CASING CLOSING	49
20. CONTROLLER OPTIONS	49
20.1. SYSTEM OPTIONS\SETTINGS	50
20.2. I\O OPTIONS\CONFIGURATION.....	51
20.2.1. Wire length compensation	51
20.3. OPTIONS\FUNCTIONS	51
20.3.1. Vacuum collector function	52
20.4. MANUAL MODE	52
20.5. SCHEME WIZARD	52
21. FUSE REPLACEMENT	53

1. SAFE INSTALLATION AND USE

The controller is designed only for household and similar use.

Before installation, service or maintenance and prior to making any connections, always disconnect power supply and make sure that the terminals and electric wires are not energized.

 When the controller is switched off using keyboard or encoder, the controller terminals are still under dangerous voltage.

 Controller may be used only for its intended purpose.

 It is required to use auxiliary protection automatics to protect hot water system, **CH** system (if any) in case of the controller or software malfunction

 Programmable settings must be selected suitably to your system type, taking into account all of its operating conditions. Wrongful settings may cause the collector or reservoir malfunction (e.g. collector overheating, etc.).

 Programmed settings may be modified only by a person who read and understood this manual.

 Use only in heating systems that are set up in accordance with valid regulations.

 Electric system to which the controller is connected must be protected with a cut-out device suitable for expected loads.

 Never use the controller when its casing is damaged.

 In any case do not alter the controller components.

 The controller has electronic disconnection for connected devices (operation 2.B according to PN-EN 60730-1). It means that at 230V voltage supply the pump outlets have dangerous voltage, even if the pumps are not controlled.

 Do not allow children access to the controller.

 Before you open casing, first disconnect power supply from the unit.

 The controller must be installed in accordance with the requirements of EN 60335-1 standard, by qualified and authorized technician.

 Do not install the unit when it is connected to voltage.

 Short circuit in pump output will damage your unit.

 Do not operate the unit when it is malfunctioning or was repaired by unauthorized persons.

 Do not mount the unit on flammable materials.

2. GENERAL

Controller PCSol 300 is an advanced electronic unit designed for distribution of heat from solar collectors. The controller is used to control solar circuit systems accordingly to indications from temperature sensors to recover highest possible energy from the collector.

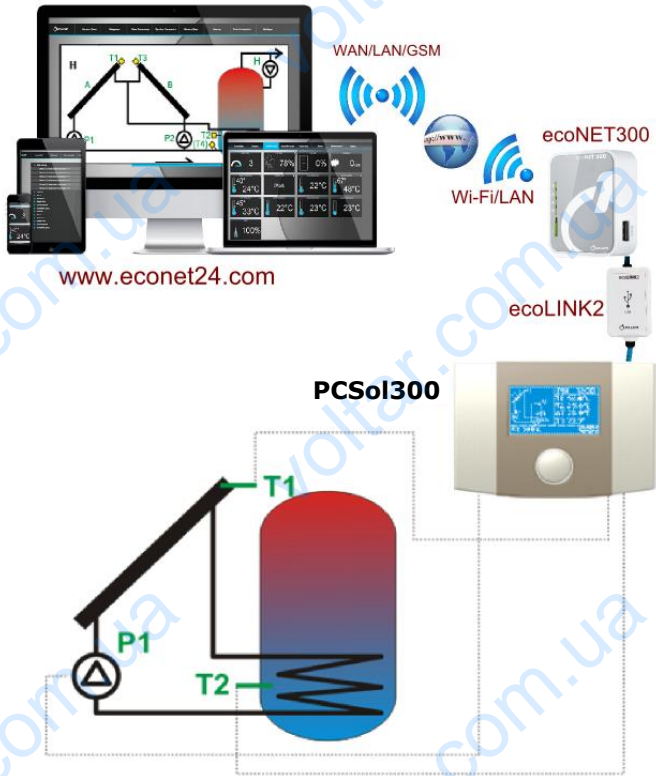

Fig. 2.1 Basic functional diagram

3. DIRECTIVE WEEE 2002/96/EC

The product you have purchased was designed and made using the highest quality components that may be recycled and reused.



If the product is marked with the above crossed bin symbol, it means that it meets requirements of the European Directive 2002/96/EC.

It is recommended to know your local electric and electronic products disposal system.

It is recommended to process in accordance with local regulations and not to dispose used products to household garbage containers. Proper disposal of outdated products will help to avoid potential adverse effects on the environment and human health.

4. DOCUMENT KEEPING

Please, keep carefully this installation and operating manual and any other relevant documents, so that they may be used at any time. In case when you move or sell the unit, please give the attached documents to its new user.

OPERATING MANUAL

PCSoI 300

5. OPERATION

The controller has TOUCH&PLAY system that facilitates its operation. Encoder is operated by its rotating and pressing.



To start the controller, keep pressed encoder knob for 3 seconds. Welcome screen will be displayed:



Fig. 5.1 Welcome screen *

* starting screen may differ depending on controller version.

After the welcome screen the controller displays the main screen.

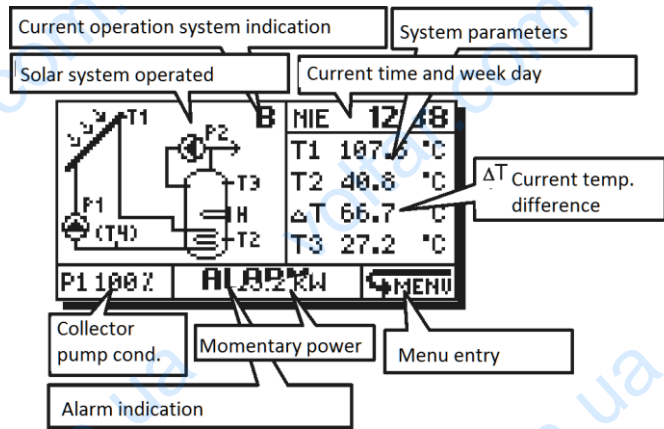

Fig. 5.2 Main screen

Controller outlets operation is each time indicated by their blinking on displayed diagram.

6. CONTROLLER MENU



Any time during controller operation, when you keep the encoder pressed for 3 seconds. It will cause exit to the main screen.

All controller settings are made through menu system. MENU is recalled by pressing encoder on main screen to select **MENU** icon.



Fig. 6.1 Recalling controller's menu

When MENU is open, the unit will display a screen with icons that represent the controller functions:

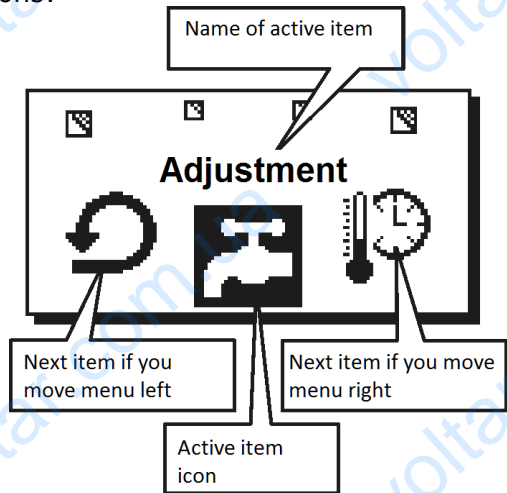

Fig. 6.2 Controller menu

In middle on the screen you can see active item icon selected as in Fig. 6.2. Now, you may turn encoder knob to move through menu items. In main MENU there will be:



Fig. 6.3 Main menu items

Where: Icon **TDHWmin** (second one) is shown only, if active scheme is **B and J**. Circulation icon (third one), if active scheme is **B, C, D, E, G, H, J, K, L**.

Values of settings are edited in scrollable submenu. Example for submenu preset is shown below. To edit setting value select required setting and press the knob; the value will start blinking. Now, rotate the knob to change the setting value. The changed value will be confirmed, when you press the knob again, and you may select other setting.

After edition in submenu you may select the following by pressing on selection:

OK Confirms changes and exits to menu; it allows reverse reaction to encoder turning;

CANCEL Rejects changes in entire submenu and exits to menu.

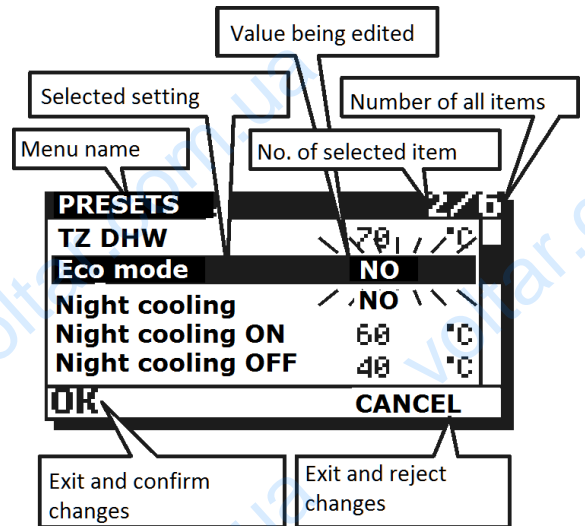

Fig. 6.4 Scrollable submenu

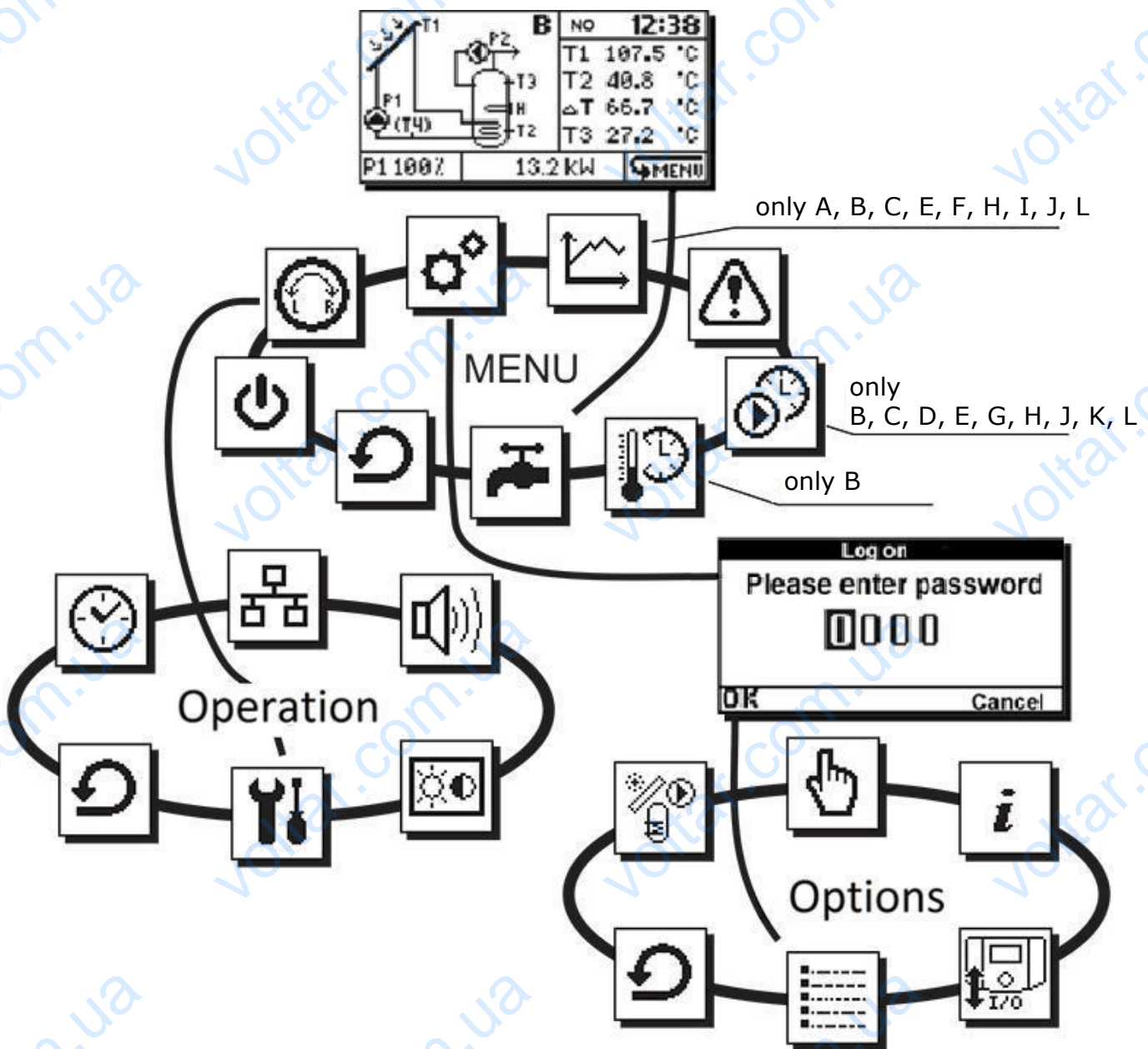
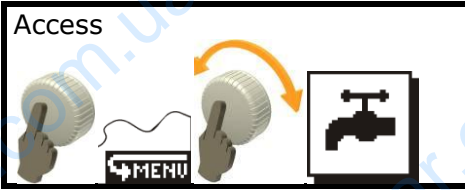

Fig. 6.5 Controller's menu structure

7. SETTINGS MENU



This menu is used to make basic settings of the controller. Change of parameters is only accepted when you use **OK** in left lower corner of the screen. Use **CANCEL** to reject any made changes. List of parameters in this menu depends on selected solar scheme. Parameters are described in details in section 13 about particular solar applications.

Depending on scheme and version of unit, the following parameters are available in Settings menu:

Parameter	Scheme											
	A	B	C	D	E	F	G	H	I	J	K	L
TsDHW	x	x	x	x	x	x	x	x		x	x	x
dTAB				x								x
dTCO							x					
Eco mode		x										
Night cooling	x	x		x	x		x	x		x	x	x
Night cooling ON	x	x		x	x		x	x		x	x	x
Night cooling OFF	x	x		x	x		x	x		x	x	x
TsPOOL						x			x			
Priority						x						
Alarm TCOLcr	x	x	x	x	x	x	x	x	x	x	x	x

8. TIME PROGRAMS



For correct operation of time programs it is required to set the clock.

8.1. TDHWmin

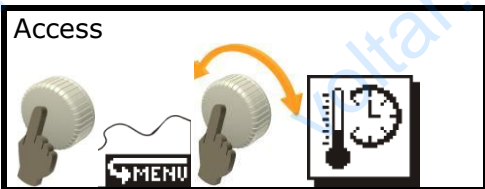

Item available only in **B** scheme

Time program **TDHWmin** is minimal temperature of **DHT** reservoir (**T3** sensor), below which the controller controls **H** output (heater or other additional heat source).

When you switch off the temperature value in **value edition box**, the time program will be set off and the controller will use stable value for **TDHWmin** parameter (single temperature value all the time), during edition it may be seen that the temperature has the same value all along the diagram.

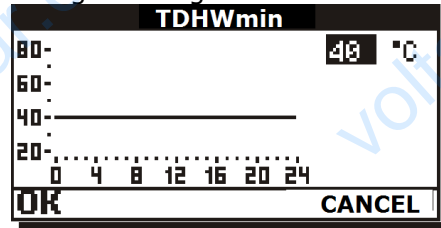

Fig. 8.1 Edition of TDHWmin value

To set the **TDHWmin** to change in time, it is required to set schedule. It is done by setting **sch.** value in **value edition box**.

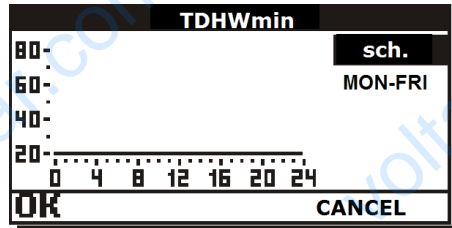

Fig. 8.2 Activating time program for TDHWmin

When **sch.** value is confirmed, new item **MO-FR** will be displayed; edit this value to select one of the three time ranges:

MO-FR – time program for days Monday to Friday,

SAT. – time program for Saturday,

SUN. – time program for Sunday.

After you confirmed desired time range, use the knob to move the position marker to the place (hour range), for which you want to edit value.

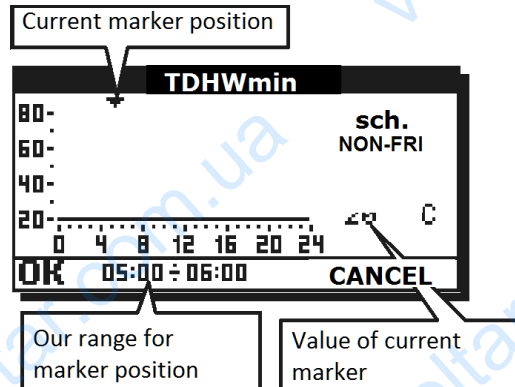

Fig. 8.3 Setting marker position

Here, press the knob to hide the position marker and to light the edition marker. When the edition marker is lit, turn the knob to change temperature value for current position marker.

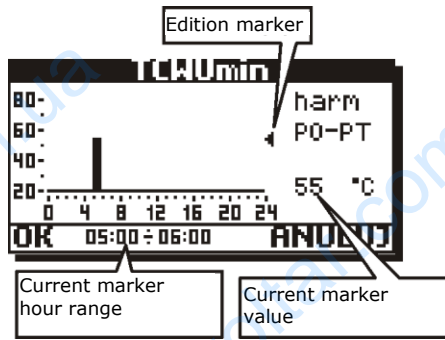

Fig. 8.4 Setting edition marker

When you set temperature and pressed the knob, both edition marker and position marker will be displayed on the screen, and you may turn the knob to copy the value to adjacent positions. Press again the knob to move to the position marker.

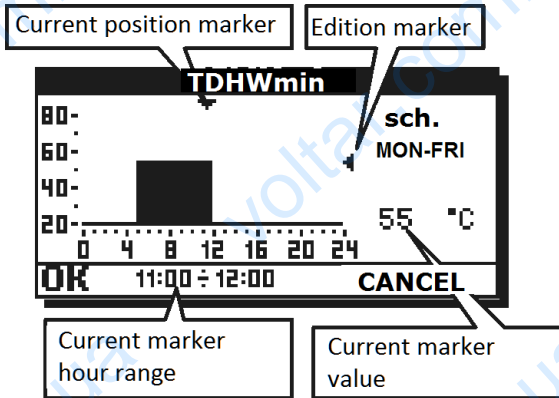
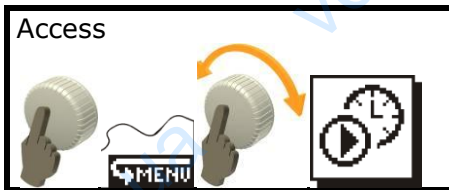

Fig. 8.5 Setting value movement

Select OK and press the knob, while in position marker mode, to confirm changes made in schedules. Activate CANCEL to exit without saving changes in schedules.

8.2.Circulation



Item available only in schemes B, C, D, E, G, H, J, K, L

Changes in circulation time programs are introduced the same like it was demonstrated for **TDHWmin** schedule settings.

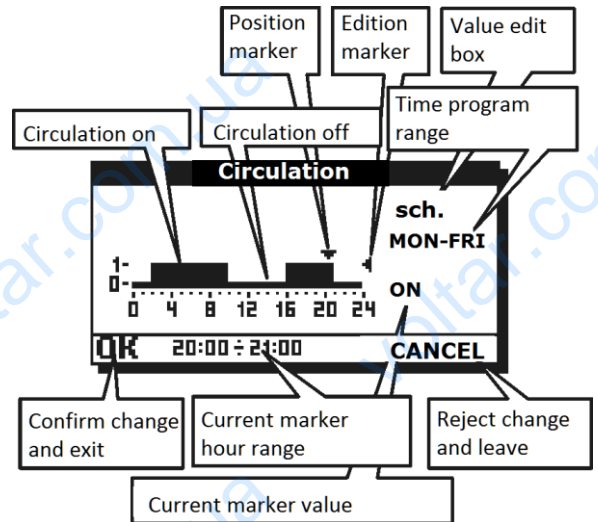
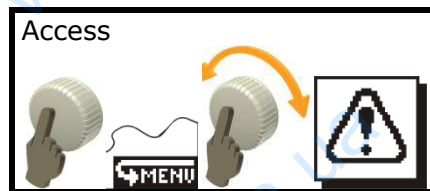

Fig. 8.6 Menu structure

Possible settings in value edit box are **YES**, **NO** AND **sch.** Value **YES** will enable constant circulation. Value **NO** will disable circulation. Value **sch.** will activate time program for circulation.

9. MENU ALARMS



The controller may alarm on any irregularities in operation.

The controller has an intelligent alarm function. It means that the controller recognizes type of alarm condition and takes respective remedy actions accordingly to the conditions. For instance, if the sensor of reservoir extra heating with a heater fails, the controller prevents extra heating for the reservoir. Despite of alarm, the solar circuit will continue correct operation and the controller will not let the reservoir to be overheated.

Type of action taken by the smart alarm depends on the alarm type and on the solar application.

When in the main screen in the screen bottom **ALARM!** sign starts blinking (Fig. 5.2), it means alarm situation. Now, entering through menu to Alarms we have access to contents and **code number** of alarm reported by the controller (Fig. below).

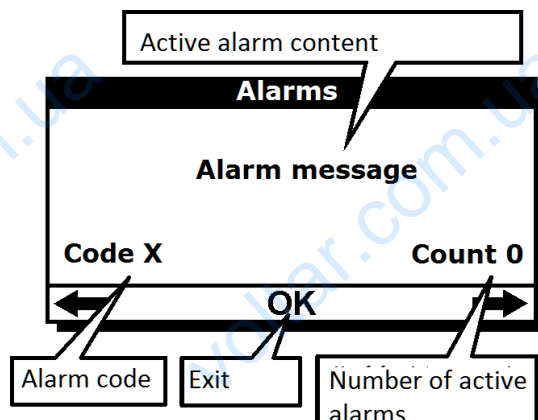

Fig. 9.1 Alarm screen

If the shown item number is higher than 1, it means multiple alarms, to be seen by turning the knob.

Lower left corner indicates the alarm code. Alarm codes are summarized in the table below, to facilitate their identifications and remedies:

List of alarms

No.	Alarm
1	DHW reservoir overheating Maximal DHW reservoir temperature has been reached (exceeded temperature specified as TDHWmax). Pump that loads heat to reservoir is stopped. This alarm has higher priority than collector alarms (if collector temperature alarms occur at the same time, solar pump will not be started whatsoever). It is required to cool reservoir, e.g. by discharging hot water.
2	Solar panel overheating P1 stop Collector pump will be stopped by the time, when collector temperature drops below TCOLmax . It is possible to start pump in manual service mode. Check work fluid flow (possible air in system or collector pump is not controlled). This alarm may be due to exceeded reservoir temperature alarm (Code 1).
3	Solar panel critical temperature It means that collector critical temperature has been reached (parameter TCOLcr) and despite reaching temperatures (TsDHW , TsPOOL) collector pump will be started, until collector temperature drops below TCOLcr . Wait for collector cool down. If menu option " Alarm TCOLcr " is set as NO , controller will not report this alarm, but it will take described actions.
4	T1 sensor malfunction Alarm informs on incorrect operation or damage to T1 sensor. Check connections for continuity (connect) or short circuit (eliminate) in sensor circuit. Alarm will stop collector pump, algorithm stops DHW reservoir loading.

5	T2 sensor malfunction Alarm informs on incorrect operation or damage to T2 sensor. Check connections for continuity (connect) or short circuit (eliminate) in sensor circuit. Alarm will stop collector pump, algorithm stops DHW reservoir loading.
6	T3 sensor malfunction Alarm informs on incorrect operation or damage to T3 sensor. Check connections for continuity (connect) or short circuit (eliminate) in sensor circuit. This alarm depends on solar thermal scheme. At B scheme (with heater) extra heating of reservoir will be stopped (output H is off) and alarm is not reported. In schemes A , C sensor has informative function and controller will not report any alarms from these sensors.
7	T4 sensor malfunction Alarm informs on incorrect operation or damage to T4 sensor. Check connections for continuity (connect) or short circuit (eliminate) in sensor circuit. This alarm depends on Solar thermal scheme. Alarm is reported only at schemes D , G or K , where operational algorithm requires this sensor. At other schemes (B , C , E , F , H , I*) T4 sensor is used to calculate heat output and its malfunction is not reported, while heat output is not calculated. <i>*T4 sensor operation in I scheme depends on dTP2 parameter, as described in section 20.1</i>
8	DHW A reservoir overheating An alarm informing that the TDHWmax defined maximum temperature of DHW A (A buffer in K scheme) has been reached. A pump loading heat into this container/buffer will be halted. Container/buffer should be cooled down, e.g. by letting warm water out and/or disconnecting alternative heat source from the container.
9	DHW B reservoir overheating Alarm on reaching maximal temperature defined in TDHWmax parameter in DHW B reservoir. Pump that loads heat to this reservoir will be stopped. Cool down this reservoir, e.g. by hot water discharge.
10	Solar panel A critical temperature In system with two collectors (only Solar thermal scheme H) alarm on exceeding critical temperature (parameter TCOLcr) in A collector. Controller, despite that preset temperature TsDHW is reached, will start collector pump P1 in order to lower temperature below critical. Wait for collector cool down. If menu option " Alarm TCOLcr " is set as NO , controller will not report this alarm, but it will take described actions.

11	Solar panel B critical temperature
In system with two collectors (only Solar thermal scheme H) alarm on exceeding critical temperature (parameter TCOLcr) in B collector. Controller, despite that preset temperature TsDHW is reached, will start collector pump P2 in order to lower temperature below critical. Wait for collector cool down. If menu option " Alarm TCOLcr " is set as NO , controller will not report this alarm, but it will take described actions.	
12	Solar panel A overheating. P1 stop
A circuit collector pump (at scheme H) will be stopped, until collector temperature drops below TCOLmax . It is possible to start pump in manual service mode.	
13	Solar panel B overheating. P2 stop
B circuit collector pump (at scheme H) will be stopped, until collector temperature drops below TCOLmax . It is possible to start pump in manual service mode.	
14	Antifreeze STOP
During antifreeze performance collector pump is started to increase temperature of too cold solar work fluid. Energy from reservoir or pool will be used for this purpose. However, if reservoir or pool temperature is near 2°C, controller will stop antifreeze function to prevent heat source damage and will initiate alarm. Antifreeze function is wider described in section Options\Functions 20.3.	

10. OPTIONS MENU

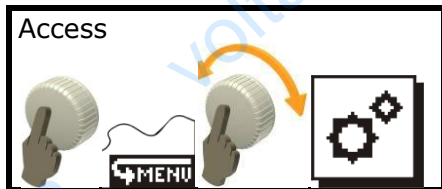

You must log-in to enter the options. Login screen is presented in Fig. 10.1



Fig. 10.1 User login screen

Access to this menu is protected with password. This menu settings are used by installer/servicer. Detailed description of the options parameters is included in installation part of the manual.

Password **0000** will display submenu parameters only for reading.

10.1. Restoring factory settings

This menu allows restoring factory parameters and settings. In login screen enter password **0002** and confirm to restore only default user settings. Service parameters will not be changed. After restoration of factory settings, parameters available in *Options* menu will not be changed.

Before restoration the controller will show a request to confirm this action.

After restoring factory settings you must set the clock, as it has been reset to date: 00:00, 01-01-2010.

10.2. Reading default settings

The controller has default settings table (that will be restored). Default settings may be read by entering password 0005 in login screen. The table is only for reading type and it may not be edited.

10.3. Clearing heat output data

Password **0003** will clear any heat output chart in the controller.

Password **0004** will clear heat output counter.

After entering passwords **0003** and **0004** the controller will display request for confirmation. Select "NO" to exit without changes.

List of codes	
0000	Table of option submenu settings only for reading
0002	Restores default settings of User group (not protected with password)
0003	Clears heat output chart
0004	Clears heat output counter
0005	Default settings table
	Access to Options submenu
	Restores default settings in groups User and Service in controller (all parameters)

11. OPERATION MANU

This menu is dedicated to the user. Here, you may change basic settings of the controller only operation.



11.1. Operation\Settings Menu

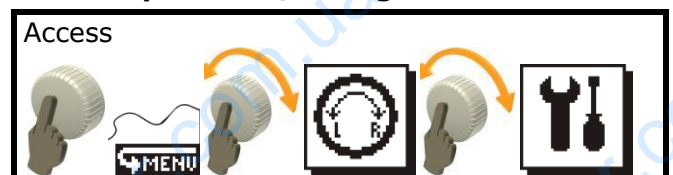

This menu allows the user to access:

Nameplate - It has three pages. Navigate between pages by turning the knob left/right. First page (1/3) allows you to read information on the unit hardware and software version;

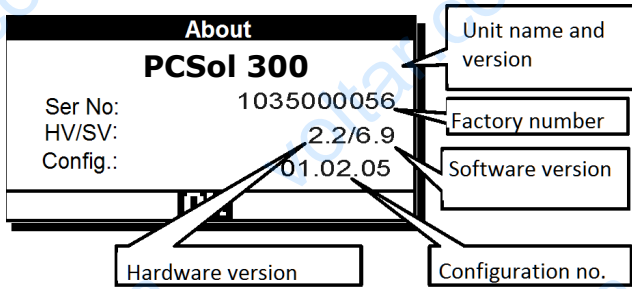

Fig. 11.1 2 Page (1/3) of Nameplate

Page (2/3) includes manufacturer's contact details.

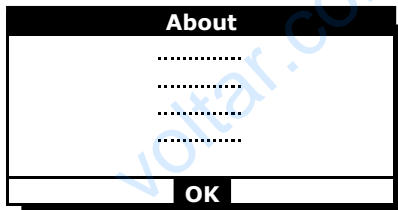

Fig. 11.3 Strona (2/3) Tabliczki znamionowej.

Page (3/3) includes information on microcontroller and software compilation;

Language - allows changing language of descriptions. You may select the following:
PL-Polish, **IT**-Italian, **ES**-Spanish,
EN-English, **RO**-Romanian, **EL**-Greek,
DA-Danish, **FR**-French, **CS**-Czech, **RU**-Russian,
DE-German;

Encoder direction - reverts reaction for encoder turning;

Time Out - inactivity time, in seconds, after which the unit automatically exits menu and the screen and knob illumination go off;

Menu speed - adjusts fastness of menu animations;

Ambient light - sets illumination pulsating after the display turned off (when **Time Out** has elapsed). This function is useful to find the controller in dark rooms. Encoder knob light pulsation will be also performed after the controller is switched off.

11.2. Operation \ Loudness Menu

This menu includes sound settings. Turn encoder to move between sound settings and controller's message sounds on and off.

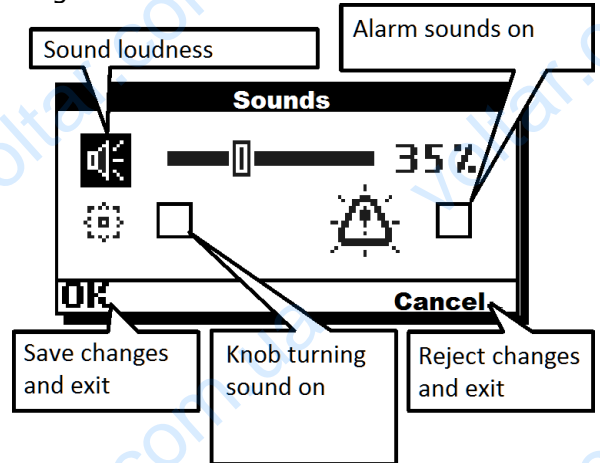

Fig. 11.4 Sound settings screen.

When sounds are switched off, the knob turning will not be confirmed by acoustic signals.

Switching alarm sounds on will cause that alarm events are reported together with sound signal. If this option is unchecked, any alarm messages will be silent: only display blinking. Alarms will not be confirmed by sound signal.

11.3. Operation \ Clock Menu



For correct operation of time programs the unit uses real-time clock, which must be set before the controller start working.

i Not set or wrongly set clock will cause incorrect operation of time programs and night cooling function

Day of week as seen in main window will be calculated automatically.

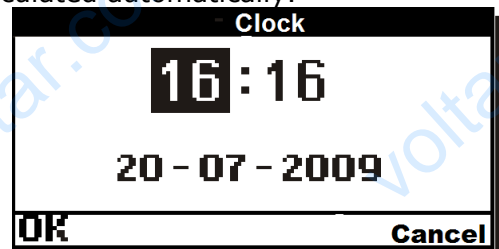
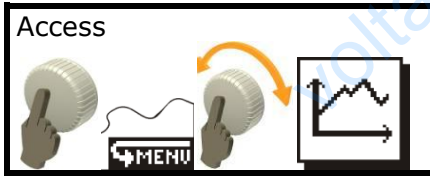

Fig. 11.5 Clock setting screen

Date and time setting must be confirmed with "OK". When you select "CANCEL", any changes will be rejected.

The controller has function of sustaining clock for 10 days. After this time, if power supply is not restored, the clock will reset.

12. HEAT OUTPUT



The controller counts energy recovered from the collector. Heat output visualization differs depending on the controller version.

Heat output function is not available in solar thermal schemes D, G and K.

Calculation of heat output and momentary power requires additional temperature sensor CT6 connected to measurement input T4. If the sensor is not connected, heat output will not be counted.

In solar applications that for their operation require four temperature sensors, heat output counting is not possible. These applications are D and G. When the schemes are on, the controller menu will not display heat output icon and the function may not be entered.

The controller logs data on recovered energy from last 14 days in the form of bar chart.

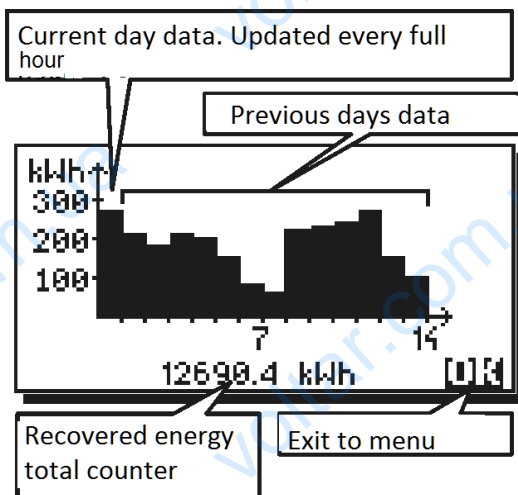

Fig. 12.1 Heat output screen

Energy total counter is displayed at the bottom of the screen. It counts energy recovered from the solar panel from the beginning of the unit's lifetime. The counter data are stored in non-volatile memory that is not affected by power losses.

First bar in the chart stands for energy recovered on current day and it is updated every full hour.

At midnight, the controller will move data one position to the right and start counting for new current day.

It is possible to turn the heat output chart on in the main screen (in place where active Solar thermal scheme is displayed). In the main screen, the controller displays data for 7 days.



Fig. 12.2 Heat output in main screen

Data are updated every full hour and the entire chart is moved at midnight. To see data for previous days, you must enter the heat output menu.

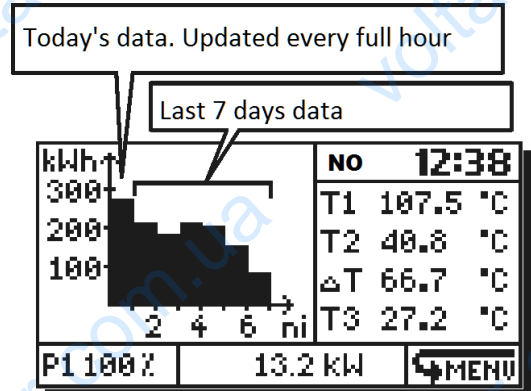

Fig. 12.3 Heat output in main screen

13. SOLAR APPLICATIONS

13.1. Night cooling



Due to the fact that in solar thermal schemes **C, F, I** there is no risk of reservoir overheating and that other protection means are provided for them against overheating, the function of night cooling is not available in these schemes.



For correct operation of night cooling it is required that the clock is set.

Night cooling function is used to cool **DHW** reservoir by emitting excess heat through cold collector. It is done by starting the collector pump.

During night cooling, any alternative sources of energy will be switched off.

There are three settings for night cooling function: **Night cooling**, **Night cooling ON**, **Night cooling OFF** and they are in *Adjustment* menu.

Night cooling- YES: switches on, **NO:** switches off the night cooling mode. When the mode is on, the controller, in hours $0^{00} \div 5^{00}$, if **T2** sensor temperature is higher than specified in **Night cooling ON** setting; will decide to start night cooling. The controller will start the collector pump in order to discharge to reservoir and will be cooling the reservoir to reach temperature specified in **Night cooling OFF** setting. In this mode, the controller additionally monitors the collector temperature; cooling will be stopped for some time, if $T1 + dToff > T2$. Regardless prior conditions, the controller will exit from the cooling mode at 5^{00} and return to normal operation. Activation of night cooling mode is indicated in the screen as blinking moon icon near the collector picture.

Night cooling ON - **DHW** reservoir temperature (measured by **T2**), when reached, if night cooling function is enabled (prior item) $0^{00} \div 5^{00}$ and the temperature at **T2** sensor is higher than **Night cooling ON** temperature, the controller will decide on night cooling activation. The controller will start the collector pump to discharge the reservoir and it will continue to cool the reservoir to the temperature set for **Night cooling OFF**.

Night cooling OFF - **DHW** reservoir temperature (**T2** sensor), to which the controller will be cooling the reservoir during night cooling function. When the temperature drops to the one specified for **Night cooling OFF**, the controller will stop night cooling.

Additionally, depending on selected scheme, the controller will control additional outputs, so as to discharge heat more efficiently.

In **scheme B** during night cooling, circulation on output **P2** will be activated (regardless any time programs etc.); heater operation will be stopped (output **H** is turned off, regardless any time programs etc.).

In **schemes D, E, G, J, K** during night cooling, circulation on output **H** will be activated (regardless any time programs etc.).

13.2. Solar thermal scheme A

Loading of **DHW** reservoir with solar collector.

This basic solar application.

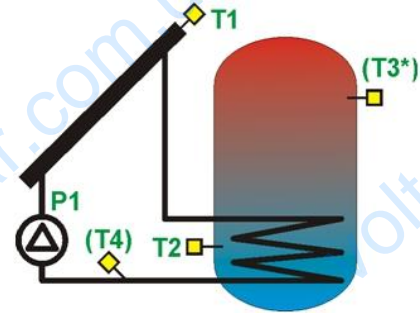

Fig. 13.1 Solar thermal scheme A

The collector pump will be started with 100% capacity, when difference between **T1** and **T2** exceeds value of **dTonDHW** setting and it will be working for the time specified in **tp** setting. If upon this time the difference between **T1** and **T2** is still above **dTonDHW**, the pump speed will remain at 100%. If the temperature difference between **T1** and **T2** drops below **dTonDHW**, the controller will start reducing the pump speed, until the moment when **T1** and **T2** difference reaches value specified in **dToffDHW** setting. When **T1** and **T2** difference is between the values $dTonDHW \div dToffDHW$, the controller will calculate and set the pump speed proportionally. When **dToffDHW** is reached, the pump will work at minimal speed (parameter **Pmin**), below it will be stopped.

System will work by the time when **T2** sensor preset temperature **TsDHW** is reached, than the collector pump **P1** is stopped.

If the collector temperature **T1** reaches critical value (**TCOLcr** parameter), the controller will allow the collector pump to be switched on to lower the collector temperature below **HP1** hysteresis parameter.

If the reservoir temperature on **T2** sensor reaches the value of **TDHWmax**, than the controller, despite critical collector's temperature (**TCOLcr**), will stop the collector pump, disabling the collector cooling. It is to protect the reservoir from overheating.

List of settings in Adjustment menu

TsDHW- Reservoir temperature preset.

Night cooling- YES enables / **NO** disables night cooling in hours $0^{00} \div 5^{00}$.

Night cooling ON – DHW reservoir temperature (**T2** sensor), if exceeded at 0^{00} , if night cooling function is enabled, the controller will decide on night cooling activation.

Night cooling OFF – DHW reservoir temperature (**T2** sensor), to which the controller will cool the reservoir (if night cooling is enabled and in hours $000 \div 5^{00}$

Night cooling ON temperature is exceeded).

Alarm TCOLcr – Switching on (YES) or off (NO) the alarm on exceeding **TCOLcr** temperature. This function does not affect the controller's operation. If the setting is set as NO, the controller will not report any alarm after **TCOLcr** temperature has been exceeded on the collector's sensor.



Due to heat discharge function, this scheme has no night cooling function.

13.3. Solar thermal scheme B

Loading of **DHW** reservoir with a function of extra heating by the use of a heater.

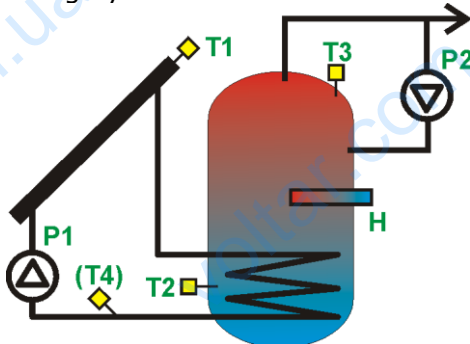

Fig. 13.2 Solar thermal scheme B

The collector pump will be started with 100% capacity, if the difference between **T1** and **T2** exceeds value of **dTonDHW** setting and it will work for the time as specified in **tP**. If after this time the difference between **T1** and **T2** is still above **dTonDHW**, the pump speed will remain at 100%. If the said difference **T1** and **T2** drops below **dTonDHW**, the controller will start reducing the pump speed, until the difference between **T1** and **T2** reaches the value specified as **dToffDHW**. When the difference between **T1** and **T2** is between the values **dTonDHW** ÷ **dToffDHW**, the controller will calculate and set pump speed proportionally. If **dToffDHW** is reached, the pump will work at minimal speed (parameter **Pmin**), below it will be stopped.

The controller will heat up **CWU** reservoir using a heater or other heat source (**H** output) up to the temperature of **TDHWmin**. Functioning

of **H** output depends also on **eco** function set up, as described in „Adjustment“ menu.

TDHWmin temperature is set through main menu item **TDHWmin**.

List of settings in Adjustment menu:

TsDHW- Reservoir temperature preset.

Eco mode- economic mode on or off (power saving) **YES** Extra heating of **DHW** reservoir with a heater or other source of heat (**H** output) to the temperature of **TDHWmin**, when the collector is not working (**P1** pump stops due to poor sunlight).

When the collector pump is started, the controller will turn the heater off (**H** output).

NO Extra heating of **DHW** reservoir with a heater or other source of heat (**H** output) up to the temperature of **TDHWmin**, regardless if the collector supplies energy or not.

Night cooling- YES enables / **NO** disables night cooling mode in hours $0^{00} \div 5^{00}$.

Night cooling ON – DHW reservoir temperature (**T2** sensor), which if exceeded at 0^{00} (if night cooling function is enabled), the controller will decide on night cooling activation.

Night cooling OFF – DHW reservoir temperature (**T2** sensor), to which the controller will be cooling down the reservoir (if night cooling function is enabled and in hours $0^{00} \div 5^{00}$ the temperature of **Night cooling ON** has been exceeded).

Alarm TCOLcr – Switches on (YES) or off (NO) the alarm on exceeding **TCOLcr** temperature. This function will not affect the controller operation. If the parameter is set as NO, the controller will not alarm when the temperature of **TCOLcr** is exceeded at the collector's sensor.

13.4. Solar thermal scheme C

Loading of **DHW** reservoir with excess heat discharge function.

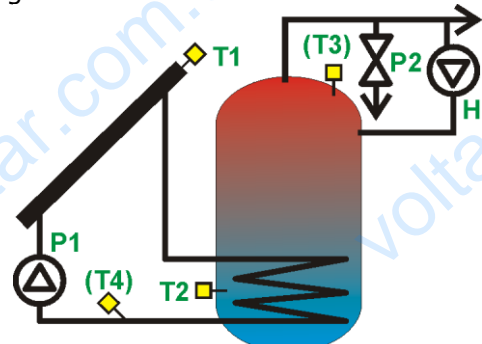

Fig. 13.3 Solar thermal scheme C

The collector pump will be started with 100% capacity, if the difference between **T1** and **T2** exceeds value of **dTonDHW** setting and it will be working for the time specified in **tP** parameter. If after this time the difference between **T1** and **T2** is still above

dTonDHW, the pump speed will remain at 100%. If the said difference between temperatures **T1** and **T2** drops below **dTonDHW**, the controller will start reducing the pump speed, until the difference between **T1** and **T2** reaches the value specified as **dToffDHW**. If the difference between **T1** and **T2** is between the values **dTonDHW ÷ dToffDHW**, the controller will calculate and set the pump speed proportionally.

When **dToffDHW** is reached, the pump will work at minimal speed (**Pmin** parameter), below it will be stopped.

The system will operate by the time when **T2** sensor temperature reaches the preset **TsDHW**, and then it will be stopped.

If **T1** collector temperature reaches critical value (**TCOLcr**), than the collector will allow the collector pump to be switched on, to reduce the critical temperature blow hysteresis **HP1**.

If the reservoir reaches maximal temperature **TDHWmax**, the **P2** input (controls discharge valve) will be operated, until the reservoir temperature (**T2** sensor) drops to the value **T2 < TDHWmax - HP2**.

List of settings in **Adjustment** menu:

TsDHW- Reservoir temperature preset.

Alarm TCOLcr – Switching on (YES) or off (NO) the alarm on exceeding **TCOLcr** temperature. This function will not affect the controller operation. If the parameter is set as NO the controller will not alarm after **TCOLcr** temperature has been exceeded at the collector's sensor.

13.5. Solar thermal scheme D

Loading of **DHW** reservoir **A** with a function for heat transfer to **DHW** reservoir **B**.

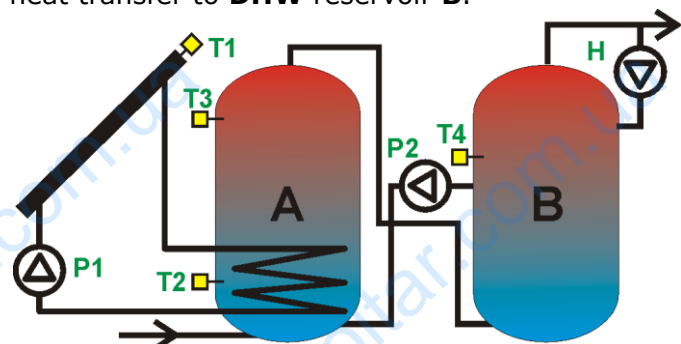

Fig. 13.4 Solar thermal scheme D

The collector pump will be started with 100% capacity, if the difference between **T1** and **T2** exceeds the value of **dTonDHW** setting, and it will be working for the time specified in parameter **tP**. If after this time the difference between **T1** and **T2** is still above **dTonDHW**, the pump speed will remain at 100%. If the said difference between **T1** and **T2** drops below **dTonDHW**, the controller will start

reducing the pump speed, until the difference between **T1** and **T2** reaches the value specified as **dToffDHW**. If the difference between **T1** and **T2** is between the values **dTonDHW ÷ dToffDHW**, the controller will calculate and set the pump speed proportionally.

When **dToffDHW** is reached, the pump will work at minimal speed (**Pmin** parameter), below it will be stopped.

If the difference between **A** and **B** reservoir temperature reaches the value of **dTAB** (**T3** and **T4** difference), **P2** will be started to transfer heat to the reservoir **B**. The pump will be stopped, if the difference between temperatures **T3** and **T4** drops below the difference **dTAB-HP2**.

If the collector temperature **T1** reaches the value of **TCOLcr**, the collector pump will be started (despite of reaching **TsDHW** temperature). This is aimed to reduce the collector's temperature. It will be stopped, when **T1** temperature drops below **T1 < TCOLcr - HP1**, or if the reservoir temperature at **T2** sensor reaches the value of **TDHWmax**.

List of settings in **Adjustment** menu

TsDHW- Reservoir temperature preset **A** and **B**.

dTAB- temperature difference between reservoirs **A** and **B** (**T3** and **T4** sensors), that when reached causes the controller to start **P2** pump, which transfers heat to the reservoir **B**. **P2** will be stopped, if the difference of **dTAB** (**T3** and **T4** temperatures) drops by the value of auxiliary hysteresis **HP2**.

Night cooling- **YES** enables / **NO** disables night cooling mode in hours $0^{00} \div 5^{00}$.

Night cooling ON – **DHW** reservoir temperature (**T2** sensor) that when exceeded at 0^{00} , if night cooling function is enabled, the controller will decide on night cooling activation.

Night cooling OFF – **DHW** reservoir temperature (**T2** sensor), to which the controller will be cooling down the reservoir (if night cooling function is enabled and if between $0^{00} \div 5^{00}$ **Night cooling ON** temperature was exceeded).

Alarm TCOLcr – Switching on (YES) or off (NO) the alarm on exceeding **TCOLcr** temperature. This function will not affect the controller operation. If the parameter is set as NO, the controller will not alarm if **TCOLcr** temperature has been exceeded at the collector's sensor.

13.6. Solar thermal scheme E

Loading of two **DHW** reservoirs **A** and **B** with priority function for reservoir **A**.

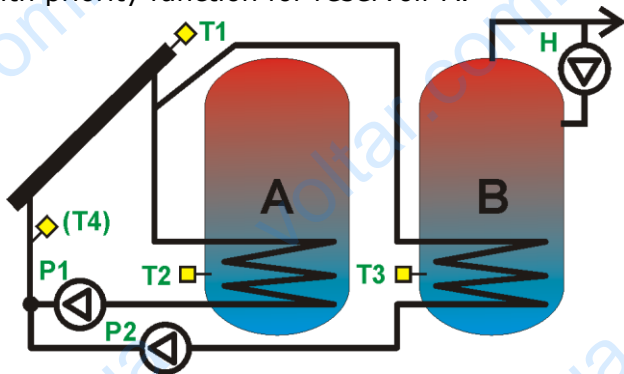

Fig. 13.5 Solar thermal scheme E

Both reservoirs are loaded up to the temperature set as **TsDHW**, measured at **T2** sensor for reservoir **A** or **T3** sensor for reservoir **B**. The controller checks which reservoir has not reached the temperature preset and decides on loading to this reservoir.

If neither of the reservoirs has reached the temperature preset, the controller first loads the reservoir **A** (reservoir **A** priority).

The collector pump **P1** for the reservoir **A** or **P2** for the reservoir **B** will be started at 100% capacity for the reservoir (depending on which one has not reached temperature preset), if the difference between **T1** and **T2** (for reservoir **A**) or **T1** and **T3** (for reservoir **B**) exceeds the value of **dTonDHW** setting. The pump will be working for the time specified in **tP** setting. If after this time the difference between **T1** and **T2** or **T3** is still above **dTonDHW**, the pump speed will remain at 100%. If the said difference between temperatures drops below **dTonDHW**, the controller will start reducing the pump speed, until the value of **dToffDHW** is reached.

If the difference between **T1** and **T2** or **T3** is between the values $\text{dTonDHW} \div \text{dToffDHW}$, the controller will calculate and set the pump speed proportionally.

When **dToffDHW** is reached, the pump will work at minimal speed (**Pmin**), below it will be stopped.

System will switch again to reservoir **A** loading, when the temperature drops below the value of **HP1** hysteresis.

Operating algorithm of the collector pump **P1** with the reservoir **A** is identical as for the pump **P2** at loading the reservoir **B**.

When both reservoirs reach the temperature preset **TsDHW**, the collector pumps will be stopped. They will be started at the moment, when in one of the reservoirs the temperature drops in relation to the temperature preset of hysteresis: respectively **HP1** for **P1** pump and **HP2** for **P2** pump. Eventually, when the temperature at the collector sensor **T1** will reach

critical value (**TCOLcr**). Then, the controller will allow switching on the collector pump for the reservoir **A** or **B** (with the priority for the reservoir **A**), by the time, when the reservoirs temperatures reach **TDHWmax**. This will cause the collector pumps to stop.

List of settings in **Adjustment** menu:

TsDHW- Reservoir temperature preset **A** or **B**.

Night cooling- **YES** switches on / **NO** switches off night cooling mode in hours $0^{00} \div 5^{00}$.

Night cooling ON – **DHW** reservoir temperature (**T2** sensor), when exceeded at 0^{00} , if night cooling function is enabled, the controller will decide on night cooling activation.

Night cooling OFF – **DHW** reservoir temperature (**T2** sensor) to which the controller will be cooling down the reservoir (if night cooling function is enabled and if in hours $0^{00} \div 5^{00}$ **Night cooling ON** temperature has been exceeded).

Alarm TCOLcr – Switching on (**YES**) or off (**NO**) the alarm on exceeding **TCOLcr** temperature. This function will not affect the controller operation. If the parameter is set as **NO**, the controller will not alarm after exceeding **TCOLcr** temperature at the collector sensor.

13.7. Solar thermal scheme F

Loading of **DHW** reservoir and pool with priorities function.

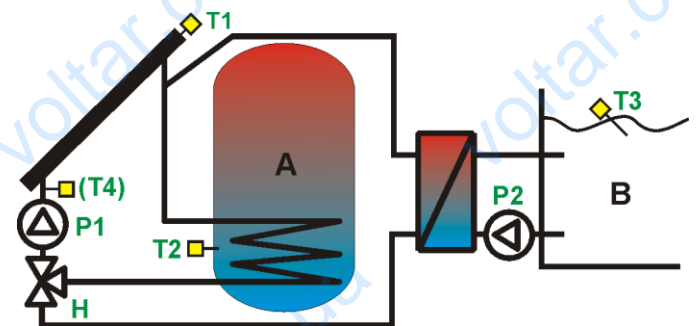

Fig. 13.6 Solar thermal scheme F

Depending on **Priority** setting (**Pool/DHW**), the system will first load the circuit to temperature preset of **TsDHW** or **TsPOOL**.

If the reservoir circuit has priority and it has not reached its temperature preset, then the collector pump will be started with 100% capacity, if the difference between **T1** and **T2** exceeds value of **dTonDHW**, and it will be working for the time specified in parameter **tP**. If after this time the difference between **T1** and **T2** is still above **dTonDHW**, the pump speed will remain at 100%. If the said difference between **T1** and **T2** drops below **dTonDHW**, the controller will start reducing the pump speed, until the difference between **T1** and **T2** reaches the value specified as **dToffDHW**. If the difference

between **T1** and **T2** is between the values **dTonDHW** ÷ **dToffDHW** the controller will calculate and set pump speed proportionally.

When **dToffDHW** is reached, the pump will work at minimal speed (**Pmin**), below it will be stopped.

After reaching preset temperature in priority circuit, the controller will switch the circuit.

The pool circuit will work analogically, except that the temperatures are calculated from **T1** and **T3** and the system uses auxiliary deltas **dTonPOOL** ÷ **dToffPOOL**. Pool exchanger **P2** pump is always switched on/off with delay as specified in **tDLY** setting in relation to **P1** pump.

When the second circuit is heated up to preset temperature, the collector pump is stopped. It will be restarted, when on any circuit the temperature drops by hysteresis value (**HP1**), in accordance with priority setting.

If the collector temperature reaches **TCOLcr** value, the collector pump will be started and the circuit will be switched to priority one in order to reduce the collector temperature. It will be stopped, when **T1** temperature drops below **T1 < TCOLcr - HP1**.

If Priority is set for **DHW**, the collector unloading will be continued only to the time when **TDHWmax** is reached, and then the system switches to the pool. In the pool circuit there is no upper limit for discharging collector's critical temperature.

Switching between **DHW/POOL** is controlled through **H** output. The circuit operation starts only when the switching time elapsed (**tVALVE**).



Due to pool system, the scheme has no night cooling function.

List of settings in **Adjustment** menu

TsDHW- Reservoir temperature preset

TsPOOL- Pool temperature preset

Priority- Priority setting: reservoir (**DHW**) or pool (**POOL**) loading.

Alarm TCOLcr – Switching on (YES) or off (NO) the alarm on exceeding **TCOLcr** temperature. This function will not affect the controller operation. If the parameter is set as NO the controller will not alarm when **TCOLcr** temperature is exceeded at the collector sensor.

13.8. Solar thermal scheme G

Loading of DHW reservoir with solar collector and boiler.

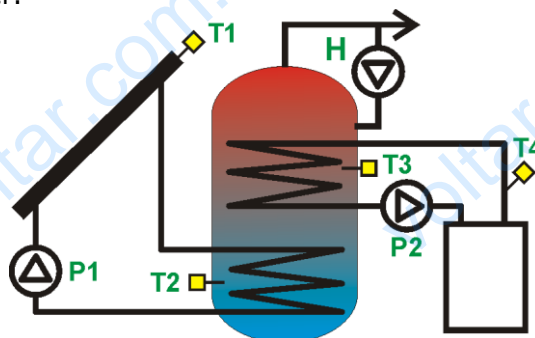

Fig. 13.7 Solar thermal scheme G

The collector pump will be started with 100% capacity, if the difference between **T1** and **T2** exceeds value of **dTonDHW** setting and it will be working for the time specified in parameter **tP**. If after this time the difference between **T1** and **T2** is still above **dTonDHW**, the pump speed will remain at 100%. If the said difference between **T1** and **T2** drops below **dTonDHW**, the controller will start reducing the pump speed, until the difference between **T1** and **T2** reaches the value specified as **dToffDHW**. If the difference between **T1** and **T2** is between the values **dTonDHW** ÷ **dToffDHW**, the controller will calculate and set the pump speed proportionally.

When **dToffDHW** is reached, the pump will work at minimal speed (**Pmin**), below it will be stopped.

If **TsDHW** temperature is reached for sensor:

T2- reservoir loading from collector will be stopped;

T3 – reservoir loading from boiler will be stopped.

The reservoir loading will be restarted, when one of the temperatures **T2** or **T3** drops below hysteresis **HP1** for **T2** or **HP2** for **T3**.

If the collector temperature **T1** reaches the value of **TCOLcr**, then the collector pump will be started (despite of reaching **TsDHW** temperature). It is aimed to reduce the collector's temperature. It will be stopped, when **T1** drops below **T1 < TCOLcr - HP1**, or if the reservoir temperature at **T2** sensor reaches the value of **TDHWmax**.

List of settings in **Adjustment** menu

TsDHW- Reservoir temperature preset

dTCO – Minimal temperature difference between **T4** and **T3** that starts loading of DHW reservoir from boiler circuit **CH** (starting **P2** pump).

Night cooling- **Yes** enables/ **NO** disables night cooling mode in hours 0⁰⁰ ÷ 5⁰⁰.

Night cooling ON – DHW reservoir temperature (**T2** sensor), when exceeded at 0⁰⁰ if night

cooling function is enabled, the controller will decide on night cooling activation.

Night cooling OFF – DHW reservoir temperature (**T2** sensor), to which the controller will be cooling down the reservoir (if night cooling function is enabled and if in hours $0^{00} \div 5^{00}$ **Night cooling ON** temperature is exceeded).

Alarm TCOLcr – Switching on (YES) or off (NO) the alarm on exceeding **TCOLcr** temperature. This function will not affect the controller operation. If the parameter is set as NO, the controller will not alarm when **TCOLcr** temperature is exceeded at the collector sensor.

13.9. Solar thermal scheme H

Loading of DHW reservoir with two collector sets oriented toward two directions.

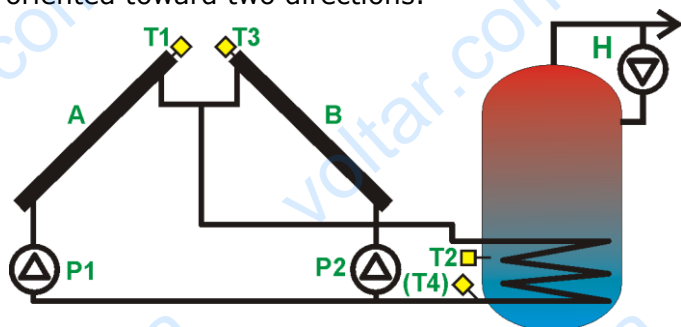

Fig. 13.8 Solar thermal scheme H

The collector pump **P1** of collector **A** will be started at 100% capacity, if the difference between **T1** and **T2** exceeds the value of **dTonDHW** and it will be working for the time specified in parameter **tP**. If after this time the difference between **T1** and **T2** is still above **dTonDHW**, the pump speed will remain at 100%. If the said difference between **T1** and **T2** drops below **dTonDHW**, the controller will start reducing the pump speed, until the difference between **T1** and **T2** reaches the value specified as **dToffDHW**. If the difference between **T1** and **T2** is between the values **dTonDHW** ÷ **dToffDHW**, the controller will calculate and set the pump speed proportionally. When **dToffDHW** is reached, the pump will work at minimal speed (**Pmin**), below it will be stopped.

The collector pump **P2** of collector **B** will be started at 100% capacity, if the difference between **T3** and **T2** exceeds the value of **dTonDHW** and it will be working for the time specified in parameter **tP**. If after this time the difference **T3** and **T2** is still above **dTonDHW**, the pump speed will remain at 100%. If the said difference between **T3** and **T2** drops below **dTonDHW**, the controller will start reducing the pump speed, until the difference between **T3** and **T2** reaches the value specified as **dToffDHW**. If the difference between **T3** and **T2** is between the values **dTonDHW** ÷ **dToffDHW**, the controller will calculate and set the pump speed proportionally. When **dToffDHW** is reached, the

pump will work at minimal speed (**Pmin**), below it will be stopped.

The system will work, until **T2** sensor reaches **TsDHW** preset, then collector pumps **P1** and **P2** are stopped.

If **T1** or **T3** collector temperature reaches critical value (**TCOLcr**), then the controller will allow switching on pump **P1** or **P2** (depending which collector has critical temperature) in order to reduce the collector temperature below hysteresis **HP1** for **P1** and **HP2** for **P2**.

If the reservoir temperature at **T2** sensor reaches the value of **TDHWmax**, the controller, despite of critical collector temperature (**TCOLcr**), will stop the collector pumps, disabling the collector cooling. It is to protect the reservoir from overheating.

List of parameters in **Adjustment** menu

TsDHW- Reservoir temperature preset

Night cooling- YES enables/ **NO** disables night cooling mode in hours $0^{00} \div 5^{00}$.

Night cooling ON – DHW reservoir temperature (**T2** sensor), when exceeded at 0^{00} if night cooling function is enabled, the controller will decide on night cooling activation.

Night cooling OFF – DHW reservoir temperature (**T2** sensor), to which the controller will be cooling down the reservoir (if night cooling function is enabled and if in hours $0^{00} \div 5^{00}$ **Night cooling ON** temperature is exceeded).

Alarm TCOLcr – Switching on (YES) or off (NO) the alarm on exceeding **TCOLcr** temperature. This function will not affect the controller operation. If the parameter is set as NO the controller will not alarm after **TCOLcr** is exceeded for the collector sensors **T1** and **T3**.

13.10. Solar thermal scheme I

Loading of pool system.

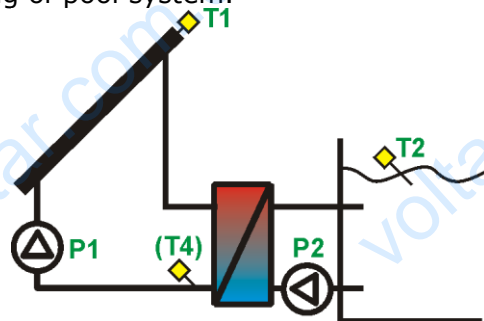

Fig. 13.9 Solar thermal scheme I

The collector pump will be started with 100% capacity, if the difference between **T1** and **T2** exceeds the value of **dTonPOOL** and it will be working for the time specified in parameter **tP**. If after this time the difference between **T1** and **T2** is still above **dTonPOOL**, the pump speed will remain at 100%. If the said difference between

T1 and **T2** drops below **dTonPOOL**, the controller will start reducing the pump speed, until the difference between **T1** and **T2** reaches the value specified as **dToffPOOL**.

If the difference between **T1** and **T2** is between the values **dTonPOOL** ÷ **dToffPOOL**, the controller will calculate and set pump speed proportionally.

When **dToffPOOL** is reached, the pump will work at minimal speed (**Pmin**), below it will be stopped.

The system operates, until **T2** sensors reaches preset temperature **TsPOOL**, and then the collector pump **P1** is stopped.

If **T1** temperature in collector reaches critical value (**TCOLcr**), then the controller will allow the collector pump to be started, in order to reduce the collector's temperature below hysteresis **HP1**.

P2 pump operation depends on **dTP2** setting. If the setting is other than **OFF**, pump **P2** will be started, if the difference **T1-T4 < dTP2** between collector and exchanger is lower than **dTP2** setting value.

At the setting value **OFF**, the pump **P2** will be started after the time **tdLY** from the start of **P1** pump.

Pool exchanger **P2** pump will be always stopped after **tdLY** time, counting from the moment when the collector pump **P1** is stopped.

List of parameters in **Adjustment** menu

TsPOOL- Pool temperature preset.

Alarm TCOLcr – Switching on (YES) or off (NO) the alarm on exceeding **TCOLcr** temperature. The controller's operation is the same at both settings. If the parameter is set as NO, the controller will not alarm after exceeding **TCOLcr** at the collector sensor.

13.11. Solar thermal scheme J

Loading of **DHW** reservoir from solar collector and from back-up source.

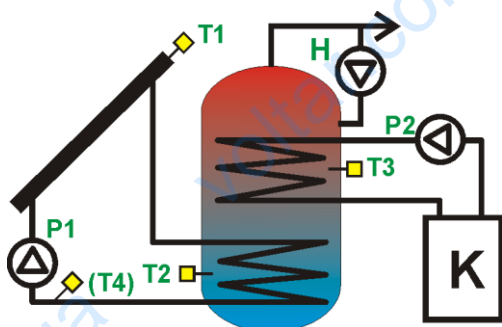

Fig. 13.10 Solar thermal scheme J

The collector pump will be started with 100% capacity, if the difference between **T1** and **T2** exceeds the value of **dTonDHW** and it will be working for the time specified in parameter **tp**. If after this time the difference between **T1** and **T2**

is still above **dTonDHW** the pump speed will remain at 100%. If the said difference between **T1** and **T2** drops below **dTonDHW**, the controller will start reducing the pump speed, until the difference between **T1** and **T2** reaches the value specified as **dToffDHW**. If the difference between **T1** and **T2** is between the values **dTonDHW** ÷ **dToffDHW**, the controller will calculate and set pump speed proportionally.

When **dToffDHW** is reached, the pump will work at minimal speed (**Pmin**), below it will be stopped.

If **TsDHW** temperature is reached for sensor: **T2**- reservoir loading from collector will be stopped by the time when measured temperature at **T2** is lower than **TsDHW - HP1**.

If **T1** temperature in the collector reaches the value of **TCOLcr**, the collector pump will be started (despite of reaching **TsDHW**). It is aimed to reduce the collector's temperature. It will be stopped, when **T1** drops below **TCOLcr-HP1**. If **TDHWmax** is reached at **T2** sensor, loading of heat to the reservoir is disabled (even if **TCOLcr** has been reached). It is to protect the reservoir from overheating.

The controller will heat **DHW** reservoir from back-up source (**P2** outlet) up to **TDHWmin** temperature at **T3** sensor. When the temperature is reached, the controller will disable **P2** output. It will re-enabled when **T3** sensor temperature is lower than **TDHWmin-HP2**. Setting **TDHWmin** may be changed through main menu item **TDHWmin** as described in section.

List of parameters in **Adjustment** menu

TsDHW- Reservoir temperature preset

Night cooling- YES enables/ **NO** disables night cooling mode in hours $0^{00} \div 5^{00}$.

Night cooling ON – DHW reservoir temperature (**T2** sensor) when exceeded at 0^{00} , if night cooling function is enabled, the controller will decide on night cooling activation.

Night cooling OFF – DHW reservoir temperature (**T2** sensor), to which the controller will be cooling down the reservoir (if night cooling function is enabled and if in hours $0^{00} \div 5^{00}$ **Night cooling ON** temperature is exceeded).

Alarm TCOLcr – Switching on (YES) or off (NO) the alarm on exceeding **TCOLcr**. This function will not affect the controller operation. If the parameter is set as NO, the controller will not alarm after exceeding **TCOLcr** for the collector sensor **T1**.

13.12. Solar thermal scheme K

Loading A container-in-container type buffer with low-temperature CH system assist.

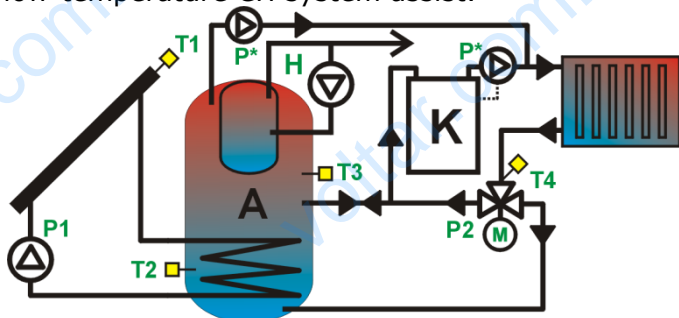

Fig. 13.11 Solar thermal scheme K

Collector pump will be activated with 100% power, when **T1-T2** difference exceeds **dTwiDHW** value and will operate for **tP** parameter time. If after this time **T1** and **T2** is still higher than **dTwiDHW**, then the pump will still operate at the highest output. If the aforementioned difference falls below **dTwyDHW** value, the regulator will start to gradually decrease pump output, until the difference reaches **dTwyDHW** value. When **T1** and **T2** difference is between **dTwiDHW ÷ dTwyDHW** values, the regulator will measure and adjust the output in a proportional manner.

When **dTwyDHW** value is reached, the pump operates at its minimum output (**Pmin** parameter). Any value below will cause it to stop.

If temperature difference **dTAB** (**T3** and **T4** difference) between **A** buffer (**T3** sensor) and **CO system return** (**T4** sensor) is not reached, **P2** output (a valve controlling return from system) will redirect return water to buffer's center. If **T3** temperature increases above **T4+dTAB**, three-way system valve will be switched in buffer's bottom direction, and **K** boiler will be powered by water from boiler's center.

"Presets" menu parameters list

TzDHW – Preset container's temperature **A** and **B**.

dTAB- temperature difference between **A** buffer and **system return** (on **T3** and **T4** sensors), after which the regulator switches three-way valve. **P2** is enabled, when **dTAB** difference (between **T3** and **T4** temperatures) falls by auxiliary hysteresis **AH2**.

Night cooling – **YES** enables / **NO** disables night cooling mode between $0^{00} \div 5^{00}$ hours.

Cooling temp ON. – **DHW** container temperature (on **T2** sensor), if exceeded, and night cooling is enabled, the regulator will begin the cool down at 0 AM.

Cooling temp. OFF – **DHW** container temperature (on **T2** sensor) to which the

regulator will be cooling down the container (if night cooling function is enabled and **Cooling temp. ON** temperature is exceeded between $0^{00} \div 5^{00}$).

TCOLkr alarm – Enabling (**YES**) or disabling (**NO**) of the alarm of exceeding **TCOLkr** temperature. This function does not influence regulator's operation. If the parameter is set to **NO**, the regulator will not set off an alarm after exceeding **TCOLkr** collector's temperature.

13.13. Solar thermal scheme L

DHW tank is loaded by two solar collector sets oriented towards two points of compass using one pump group and collector circuit separating valve.

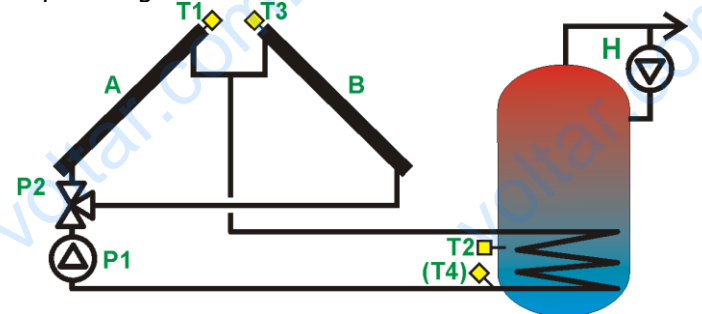

Fig. 13.12 Solar thermal scheme L

Regulator selects the solar collector of higher temperature to operate. Solar collector serving pump is activated with 100% capacity once the difference of **T1** or **T3** (subject to the solar collector selected) and **T2** has exceeded the value of **dTonDHW**. The pump will work over the time set in **tP**. **P2** valve is set at the position appropriate to switch the system into selected solar collector. If, upon elapsing of this time, the difference of **T1** or **T3** and **T2** is still in excess of **dTonDHW** value, the pump rpm value will remain set at 100% all the time. Once the difference between **T1** or **T3** and **T2** has dropped below **dTonDHW** value, regulator starts reducing pump rotary speed until the difference of **T1** or **T3** and **T2** has reached the value set in **dToffDHW**. In case the difference of **T1** or **T3** and **T2** falls within the range from **dTonDHW** to **dToffDHW**, the regulator computes and sets the rpm value proportionally.

Once the difference of **T1** or **T3** and **T2** has reached the value set in **dToffDHW**, the pump runs with minimum rpm value (**Pmin** parameter) and in case it has dropped below this value, the pump stops.

If, in case of operation with one solar collector, temperature of the second collector has grown above the temperature of the first one (or v.v.) and the value of **dTonDHW** has been reached, the regulator switches over the solar collector circuit.

Once the pump has stopped, **P2** valve is set at "0" (power supply is cut off).

The system operates until the temperature of water in DHW tank has reached the value set in **TzCWU** (read-out of T2 sensor), then it stops.

Once **T1** or **T3** temperature of solar collector has reached the critical value of **TCOLkr**, the regulator (despite the set temperature of **TzCWU** has been reached) allows to start **P1** collector serving pump and to set **P2** valve at the solar collector of higher temperature in order to reduce the temperature of the collectors below the value of **HP1** hysteresis.

Once the temperature of DHW tank has reached the value of **TCWUmax** (read-out of **T2** sensor), the regulator, in spite of reached critical temperature of the collectors (**TCOLkr**), stops collector serving pumps to prevent collector cooling down. It protects DHW tank from overheating.

List of parameters available in „Settings” menu

TzCWU - set temperature of DHW tank.

Night cooling – YES / NO - switches on/off night cooling mode active from 00⁰⁰ ÷ 05⁰⁰.

Night cooling ON – temperature of DHW tank (read-out of **T2** sensor), upon excess of which, the regulator will activate night cooling mode at 0⁰⁰ (provided that night cooling function is enabled).

Night cooling OFF – temperature of DHW tank (read-out of **T2** sensor) to which the regulator will cool down DHW tank (provided that night cooling function is enabled and temperature of **Tschl WŁ** has been exceeded within the period of time from 00⁰⁰ to 05⁰⁰).

Alarm TCOLkr – switches on (YES) or off (NO) the "Temperature of **TCOLkr** exceeded" alarm. This function does not affect the regulator operation. Setting this parameter at "NO" causes the regulator will not produce the alarm of exceeded **TCOLkr** temperature for **T1** and **T3** solar collector sensors.

14. SHUT DOWN

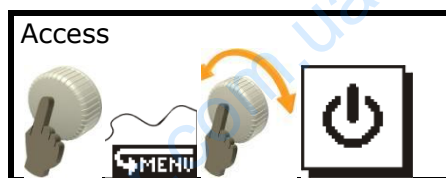

This option displays screen windows, where you can confirm that you want to shut down the unit. After confirmation the controller is switched off.

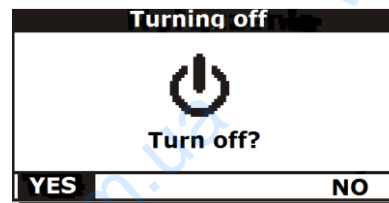

Fig. 14.1 Shut down screen



The controller may be also switched off in main screen by pressing the encoder for 3 seconds. Confirmation screen will be displayed like in Fig. 14.1 After confirmation the controller is switched off.

15. ACCESS TO THE UNIT OVER THE INTERNET

By using an additional module - ecoNET300, the unit enables remote access to its data over a Wi-fi or LAN network. The interface is operated

by an ordinary search engine installed in any stationary and mobile communication devices.



Pumps are stopped after switching off the controller.

15.1. Basic data reading

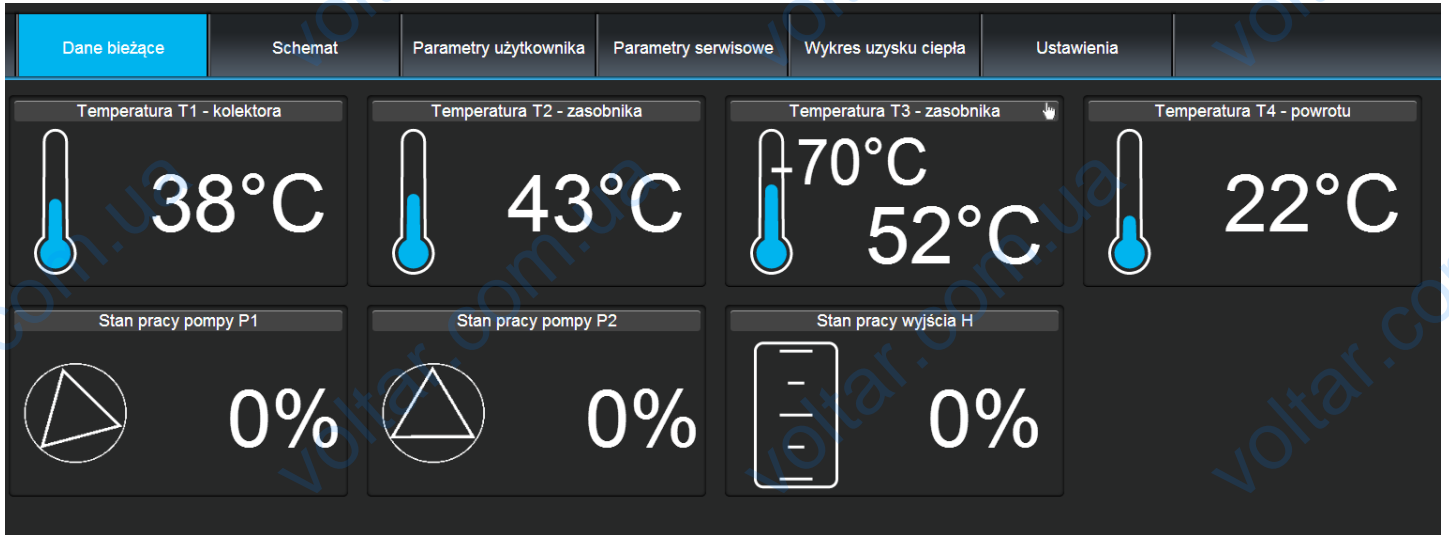

Fig. 15.1 WWW interface –tiles

15.2. Diagram of active solar circuit system

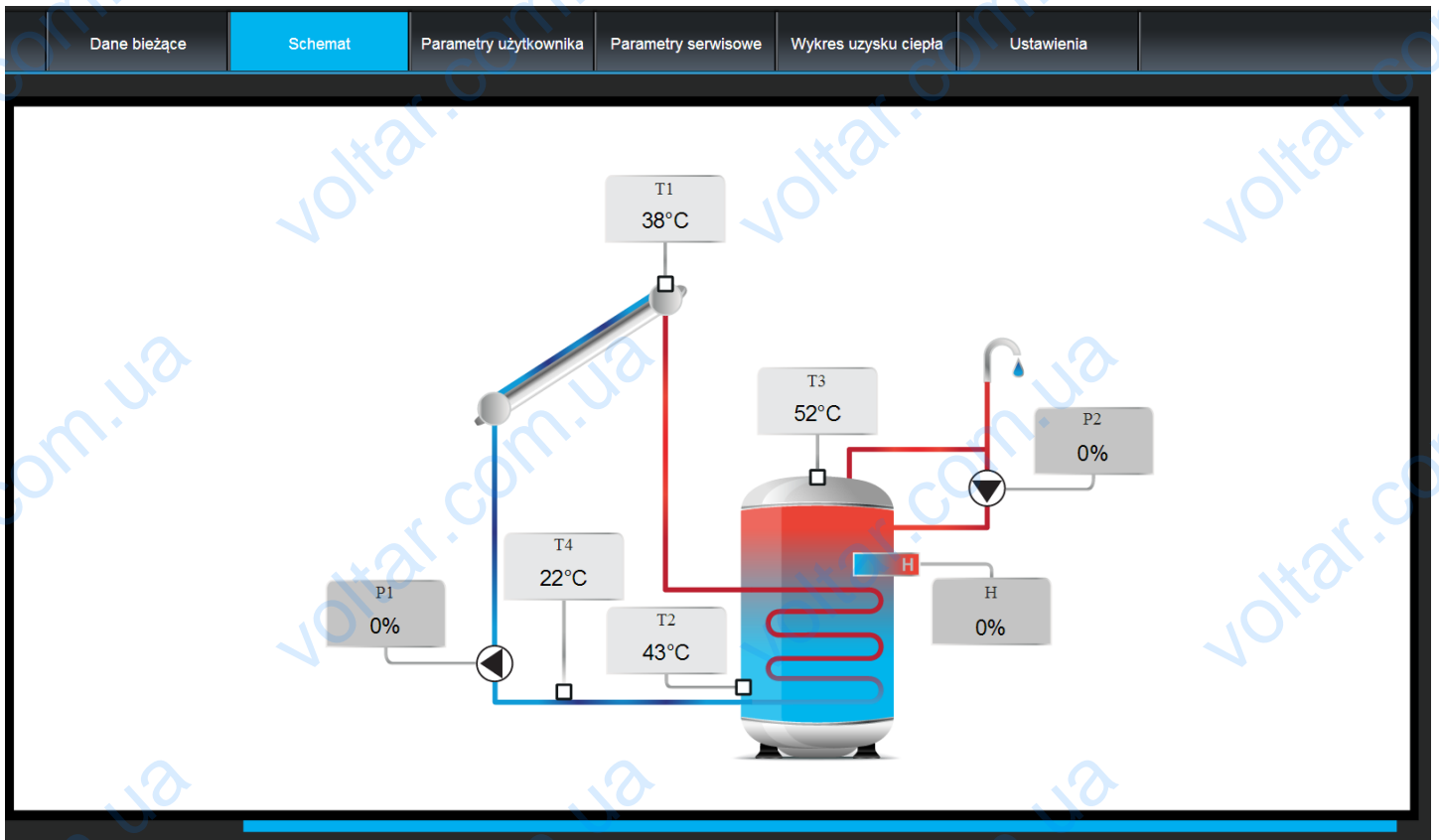

Fig. 15.2 WWW interface- diagram

15.3. User parameters

Dane bieżące	Schemat	Parametry użytkownika	Parametry serwisowe	Wykres uzysku ciepła	Ustawienia	
					Użytkownik	
Autoryzacja						
Temperatura T1 - kolektora					38.6	°C
Temperatura T2 - zasobnika					43.4	°C
Temperatura T3 - zasobnika					52.4	°C
Temperatura T4 - powrotu					22.4	°C
Stan pracy pompy P1					Wyłączony	
Stan pracy pompy P2					Wyłączony	
Stan pracy wyjścia H					Wyłączony	
Temperatura zadana zasobnika CWU					70	°C
Tryb eco wyłączający dogrzewanie zasobnika grzałką gdy świeci słońce					Wyłączony	
Tryb schładzania nocnego					Wyłączony	
Temperatura zasobnika włączająca tryb schładzania nocnego					60	°C
Temperatura zasobnika do której będzie schładzany podczas działania schładzania nocnego					40	°C
Identyfikator UID regulatora					1C00M1P16SSJ4L9I	
Nazwa regulatora					ecoSOL 300	
Log					0	
Numer schematu instalacji grzewczej					B	
Połączenie z siecią bezprzewodową					Nieaktywne	

Fig. 15.3 WWW interface – user parameters

15.4. Service parameters

Dane bieżące	Schemat	Parametry użytkownika	Parametry serwisowe	Wykres uzysku ciepła	Ustawienia	
Kolektor A					1	
Kolektor B					0	
Aktualna wartość alarmów					00000000000000	
Moc chwilowa kolektora słonecznego					0	W
Całkowita wydajność					172967.16	Wh
Energia odzyskana z kolektora					855	W
Energia odzyskana z kolektora w dniu dzisiejszym					0	W
Energia odzyskana z kolektora w dniu wczorajszym					0	W
Energia odzyskana z kolektora dwa dni temu					0	W
Energia odzyskana z kolektora trzy dni temu					0	W
Energia odzyskana z kolektora cztery dni temu					0	W
Energia odzyskana z kolektora pięć dni temu					0	W
Energia odzyskana z kolektora sześć dni temu					0	W
Energia odzyskana z kolektora siedem dni temu					0	W
Energia odzyskana z kolektora osiem dni temu					0	W
Energia odzyskana z kolektora dziewięć dni temu					0	W
Energia odzyskana z kolektora dziesięć dni temu					0	W
Energia odzyskana z kolektora jedenaście dni temu					0	W
Energia odzyskana z kolektora dwanaście dni temu					0	W
Różnica detekcji trendu temperatury kolektora					3.89	
Wartość zapisana temperatury T1 w funkcji kolektora próżniowego					0	°C
Wartość zapisana temperatury T3 w funkcji kolektora próżniowego					0	°C
Numer fabryczny					4	
Wersja sprzętu / Wersja oprogramowania					3.7.2/3.12	
Wersja pliku konfiguracyjnego					1.2.3	

Fig. 15.4 WWW interface - service parameters

15.5. Heat yield graph

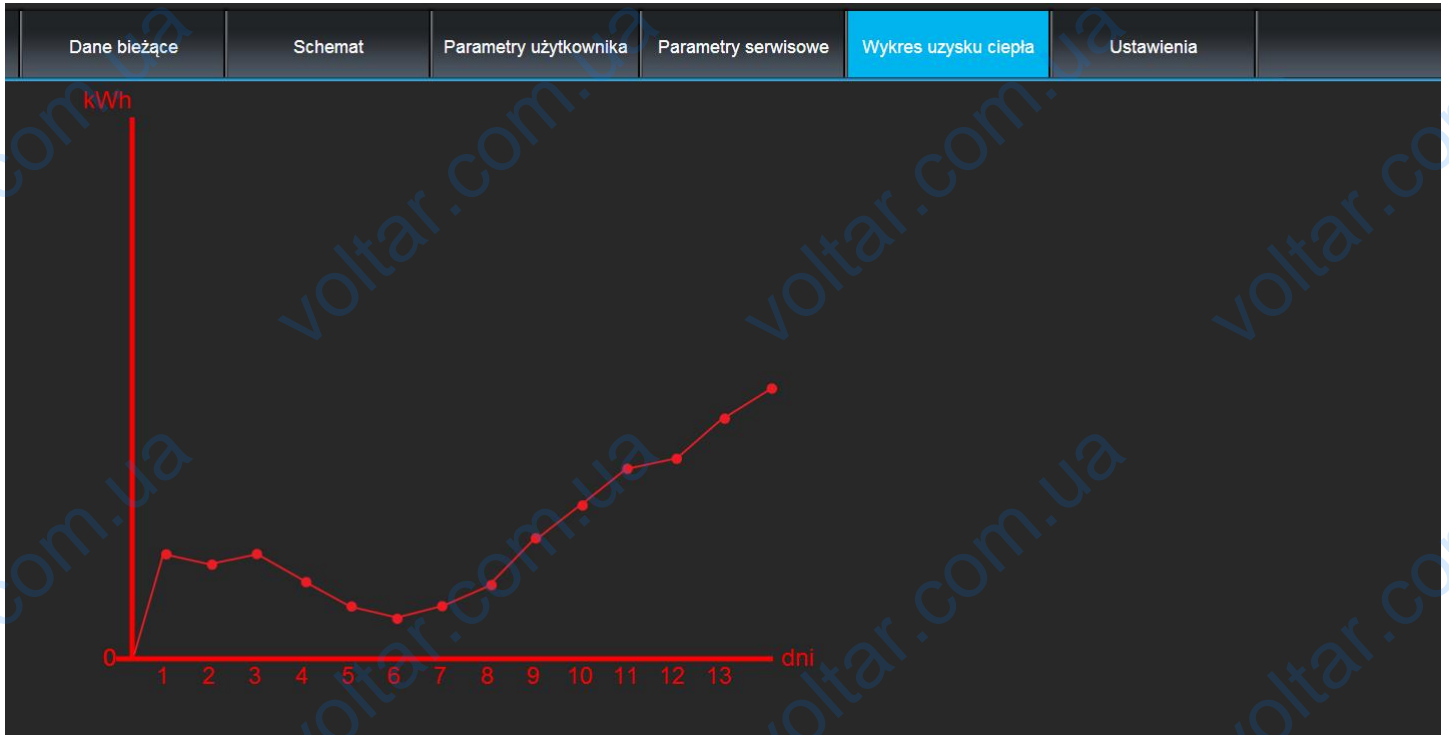

Fig. 15.5 WWW interface - heat yield graph

15.6. Network settings

Section	Parameter	Value / Action
Sieć	Ethernet	10.1.2.200 Połączono
	WiFi	0.0.0.0 Rozłączono
	Nazwa sieci:	Wybierz (dropdown) Odśwież listę sieci (button)
	Siła sygnału:	(indicator)
	Typ zabezpieczeń:	Brak (dropdown)
Hasło:	(input field)	
Główny serwer	Adres:	econet24.com
	Status:	Połączono Sprawdź dostępność serwera (button)
Kontroler	Identyfikator:	Plum Sp. z o.o. ecoSOL300 000000004 3.7.2/3.12
	UID:	1C00M1P16SSJ4L9I
	Typ:	gm3
	Częstotliwość odświeżania [s]:	5 (input field)
Aplikacja	Wersja oprogramowania:	1.08.1663
		Istnieje nowa wersja oprogramowania (1.08.1602) Aktualizuj (button)
		Zmień hasło (button)
		Zastosuj (button)

Fig. 15.6 WWW interface - network settings screen

INSTALLATION MANUAL

PCSoI 300

16. TECHNICAL DATA

Measurement inputs (low-voltage)	Collector temperature input (T1)
	Temperature input (T2)
	Temperature input (T3)
	Temperature input (T4)
Other inputs/outputs: (low-voltage)	Communication port RS485
High-voltage outputs:	Output (H) 5-6V/0,1A (DC)
	Output P1: 230V/ max 0,5A (AC)
	Output P2: 230V/ max 0,5A (AC)
Power supply:	Controller: 230V(AC), 50Hz. I=1.02A*
Load ability P1,P2:	not more than 0.5A(AC)/output
Operating conditions	0° ≤ Ta ≤ 40°C, humidity 10-90%, without condensation
Protection degree	IP 20
Weight	~280g

* Power intake only by controller is 0.02A, 1,5W

Table of temperature measurement accuracy:

Internal structure	Pt1000 class B (CT6 and CT6w)		
Temperature ranges	-40÷0°C	Temperature ranges	-40÷0°C
Accuracy*	±2°C	Accuracy*	±2°C
Displayed range	T1 (T3**)	Displayed range	
	T2, T3, T4		

* at ambient temperature of 23°C

** in scheme H

16.1. Elements of the set

- Controller PCSol 300 1 pc.
- Temperature sensor T1 (CT6w) 1 pc.
- Temperature sensor T2÷T4 (CT6)* 1 pc.
- Operating and installation manual 1 pc.

*To use solar thermal scheme **B, C, E, F** it is required to purchase one additional CT6 sensor.

* To use solar thermal scheme **D, G, K** it is required to purchase two additional CT6 sensors

* To use solar thermal scheme **H, L** it is required to purchase one additional CT6W sensor.

*To use heat output function it is required one additional CT6 sensor (Note: does not apply to schemes **D, G, K** in which heat output is not counted).

17. INSTALLATION OF PCSol 300

The controller is designed for operation in the environment where only dry conductive contaminations may be present (2 degree of contamination according to PN-EN 60730-1).

In addition, the controller may not be used in water condensation conditions and it may not be exposed to water.



The unit software does not ensure required protection level that must be assured by external protections of the solar system.

17.1. Installation of the controller

The controller is designed for vertical wall-mounted installation. External circuit wires are supposed be lead on surface. Mounting hole locations are presented as in the casing. Hole spacing dimensions are presented also in Fig. 17.2



Wires that enter the controller must be secured at entry locations.



Before opening the unit casing, disconnect power supply. The unit installation must be done at disconnected voltage.



The unit has any fuse replaceable by the installer or use. If the fuse was burnt during installation or operation, it means damage of the unit. Send the unit to authorized service for repair.



Controller must be installed by qualified and authorized technician in accordance with EN 60335-1 standard.

For how to open the unit casing see the picture below.

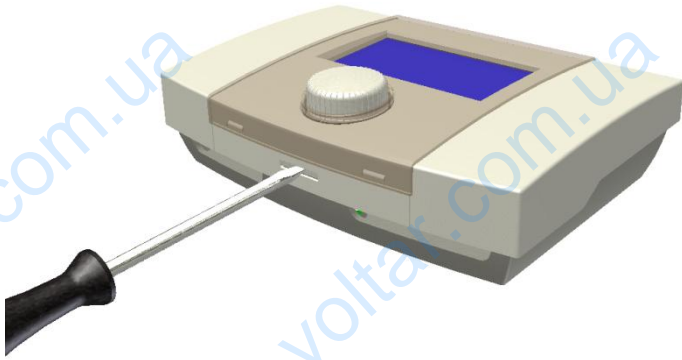

Fig. 17.1 Casing opening

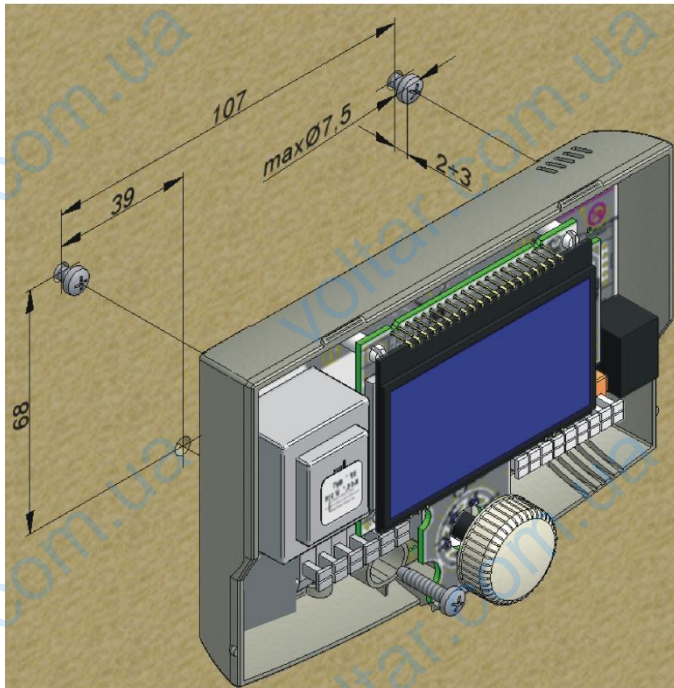









Fig. 17.2 Controller on-wall mounting

The controller must be installed in a way that:

-  it is securely mounted on flat base, using all mounting points (3 in controller casing itself and 4 intermediate plate);
-  degree of protection is ensured suitably to environmental conditions;
-  dust and water access is prevented;
-  permissible operating temperature is not exceeded for the controller (40°C);
-  air exchange inside casing is allowed;
-  access to dangerous parts is disabled;
-  electrical installation, to which the controller is connected, must be equipped with the device that allows disconnection of both supply poles, in accordance regulations that applies to such systems.

17.2. External circuits connection.

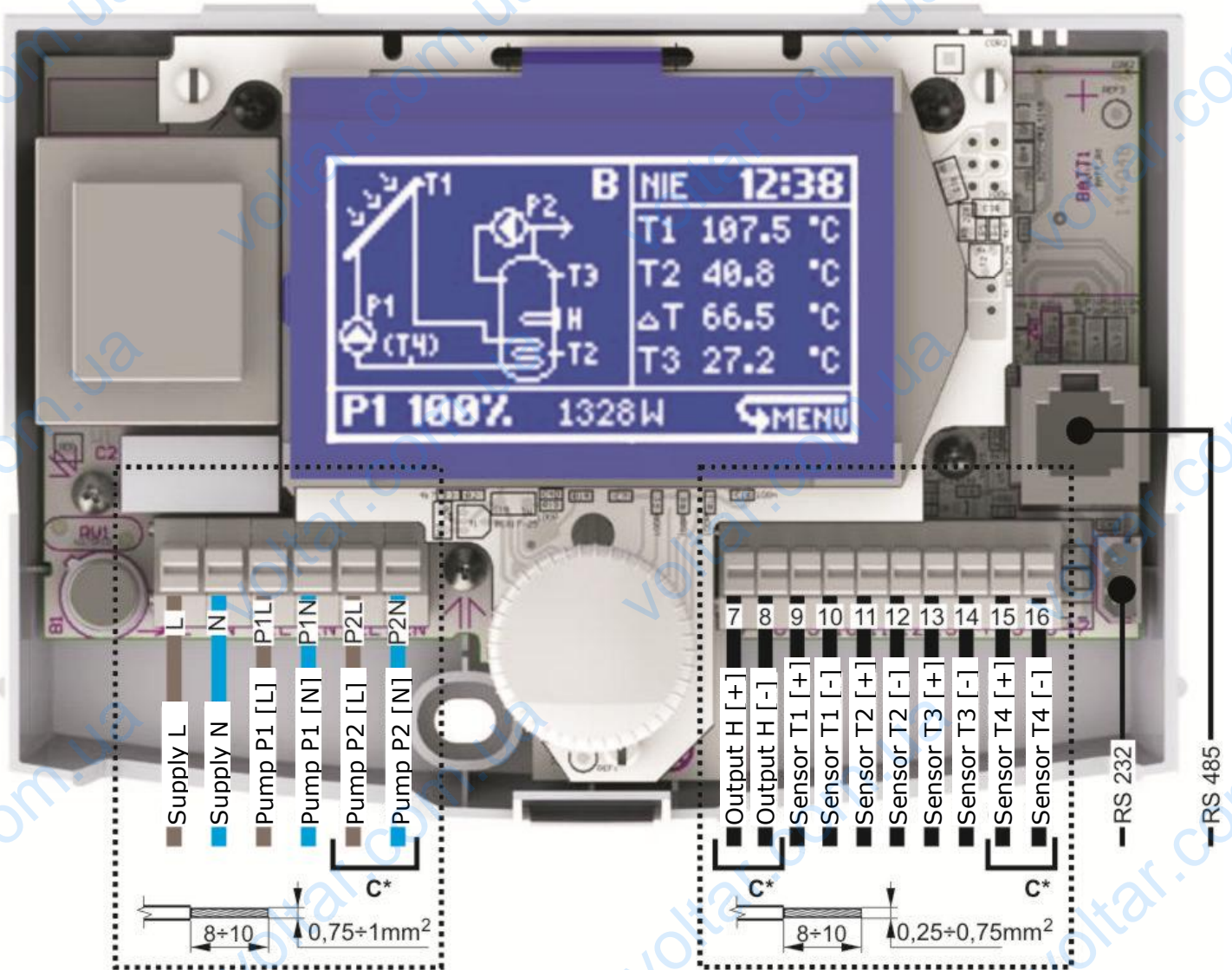

Fig. 17.3 Controller inside view with terminals

17.2.1. Use of connectors

The controller is provided with spring loaded terminals suitable for reception of wire with an end sleeve.

The table below includes permissible size ranges for wires connected to the controller terminals:

Circuit type	Wire cross-section
Power supply circuits	0,75÷1mm ² *
Low-voltage circuits	0,25÷0,75mm ²

* For installations with bare wire cables the maximal size is 1.5mm²

For good connection between the terminal and cable, insulation and sleeve free length should be in the range of **8÷10mm**.

To place wire in terminal press the terminal push with a flat screwdriver, insert the wire end (with a sleeve on) and then release the push.

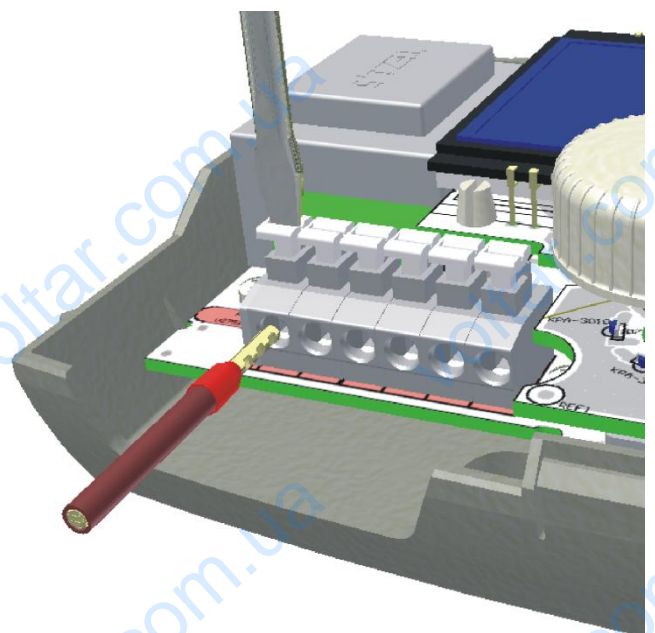

Fig. 17.4 Using clamped terminals

17.2.2. Power supply connection

The controller is designed for supply voltage 230V~, 50Hz. Supply is connected to terminals L, N. Electric connection diagram is presented in Fig. 17.5. and Fig. 17.6.

230V supply wires must be lead so as their contact with sensor and other low-voltage cabling is prevented, additionally, all cables may not contact surfaces with temperatures that exceed the cables operating temperature limits.

The controller has no PE protective connector, because the controller itself does not require grounding. PE terminals of the pump shall be connected with PE of supply network, according to periphery instructions and regulation concerning electric systems. Proper electric installation method is responsibility of the electrician. It is recommended to connect PE circuits through external screw connector, as presented in diagrams.

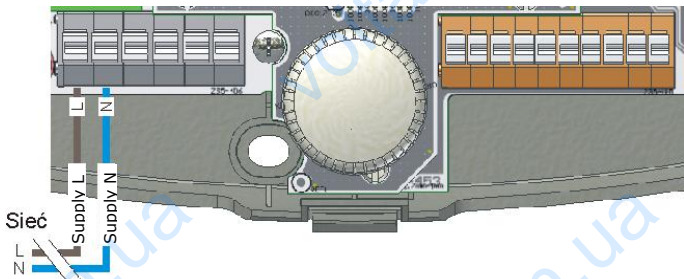

Fig. 17.5 Power supply connection

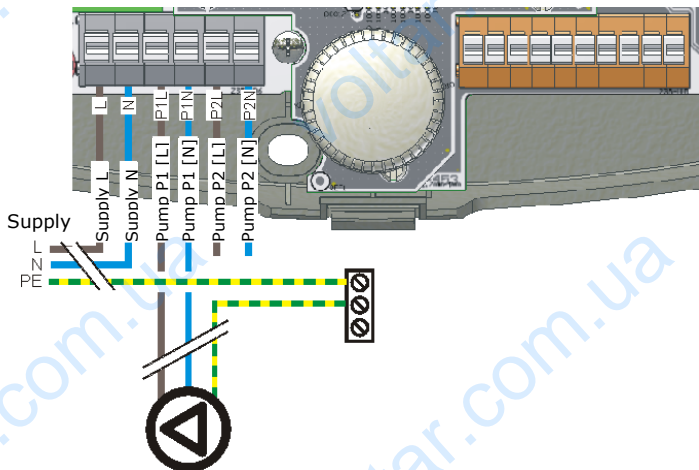

Fig. 17.6 Connection of pumps

Pump **P2** is connected analogically as pump **P1**.

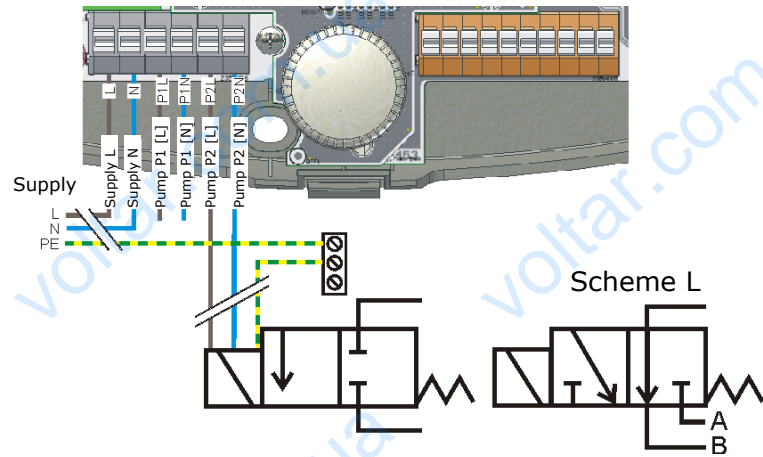



Fig. 17.7 Electro-valve connection

 The connection shown in fig. 17.7 requires electro-valve coil adjusted to ~230 voltage.

17.2.3. Temperature sensor connection

Sensors are provided with two wires:

- CT6w 1m long, silica wire;
- CT6 2m long.

If you need longer cables, use 0.5÷1.5mm² cable not longer than 30 meters, and connection points must be secured against short circuit and humidity. Take a note that when extending the line with additional wire the sensor circuit resistance increases and it may cause errors in measurement.

Such errors may be adjusted by the wire length compensation function described in menu **I/O Configuration**. Compensation method is described in section 20.2.1.

 *CT6w sensor is provided with special high-temperature silica cables, it must not be replaced with CT6 sensor, because of possible insulation damage when the collector temperature is high.*

Table of sensor resistance against temperature:

temperature	resistance
-25 °C	901,9 Ω
-20 °C	921,6 Ω
-10 °C	960,9 Ω
0 °C	1000,0 Ω
10 °C	1039,0 Ω
20 °C	1077,9 Ω
25 °C	1097,3 Ω
30 °C	1116,7 Ω
40 °C	1155,4 Ω
50 °C	1194,0 Ω
60 °C	1232,4 Ω
70 °C	1270,7 Ω
80 °C	1309,0 Ω
90 °C	1347,1 Ω
100 °C	1385,0 Ω
110 °C	1422,9 Ω
120 °C	1460,7 Ω
130 °C	1498,3 Ω
140 °C	1535,8 Ω
150 °C	1573,2 Ω
160 °C	1610,5 Ω
170 °C	1647,7 Ω

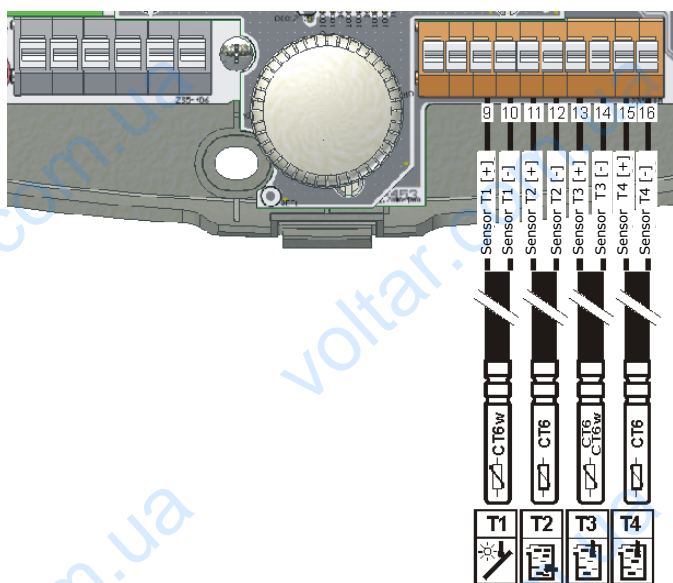

Fig. 17.8 Connection of temperature sensors*

*Sensor's function may differ from the drawing depending on selected scheme

17.2.4. Temperature sensor installation

Temperature sensors are equipped with brass coat with diameter of 6mm and 50mm long. They should be installed possibly close to the temperature measurement point. The sensors must be installed so that the brass coat is thermally insulated from the environment.

The collector temperature sensor must be located in the collector tube possibly deep, as this is conditional for correct measurement.

If you need mount your sensor on pipe surface (e.g. **CH** temp. measurement), then the sensor coat must be attached using a brace, and the jointing point to insulate e.g. with foam or other insulating material, so that there is sufficient temperature convection to the sensor.

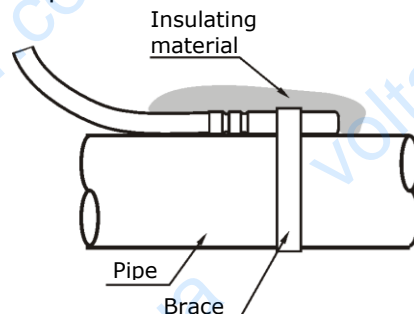

Fig. 17.9 Sensor installation on pipe surface

17.2.5. Output H connection

Output **H** is adapted to connect relay supplied with voltage of 5...6V (**with coil resistance not lower than 60Ω**) and power up to 0.5W.

Heater

For a heater connection, use relay connected as shown in Fig. 17.10. Wire that connects the controller and transmitter must not have resistance bigger than 1Ω (see Table of wire lengths and resistances in the section on wire length compensation 20.2.1).

The reservoir heater must be connected through a relay with maximal contact current not lower than the heater's nominal current. Recommended relay type is **Finder 44.62.7.006.0000** that has load ability of **2x10A**. It is suitable for heater control (resistance loads) with power up to 2.5k VA. The relay together with a base is available as accessories. If you choose to use other relay, check its technical parameters and if it meets safety standards.



Current received by a receiver may not be higher than nominal current of the relay load. Otherwise, it may be damaged and in extreme case it may cause damage to solar or heating system.

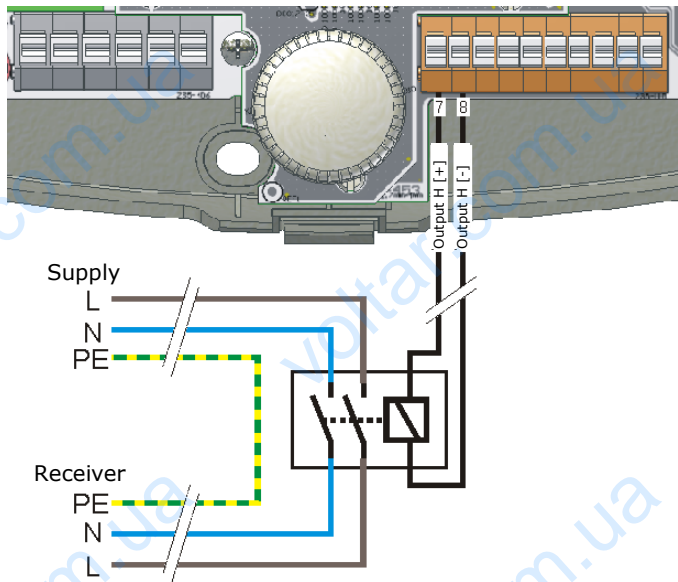

Fig. 17.10 Connection of relay to H output.

Three-way switching valve

The output may be used for a three-way switching valve that is controlled:

- 1. Unipolarly with return spring:** such valve connect to **H** output of the controller through a relay, like in Fig. 17.10
- 2. Bipolarly, right-left rotations (3-wire control):** Neutral conductor is connected directly to the valve, while wires that control direction of rotations are connected via a relay and its contacts to relevant terminals. Status relations on **H** outlet and respective direction of the valve switching are presented in application schemes. Change of rotation direction switching will cause incorrect operation of the unit.

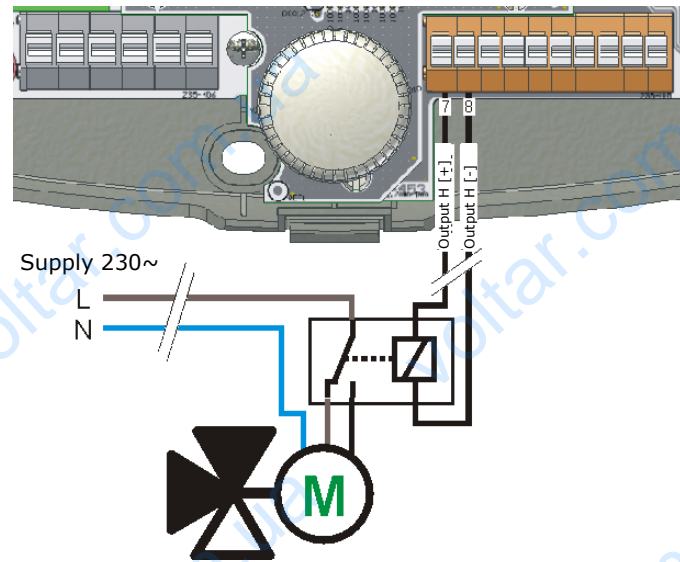

Fig. 17.11 Connection of three-way, bipolarly controlled valve to H output

If the valve has grounding terminal, connect it directly to the valve.



Connection of other valve types than specified above may lead to undesired operation and is not recommended.

17.2.1. ecoNET internet module connection

ecoNET300 module can be connected to the Internet in two ways:

- over Wi-fi to the local access point,
- directly through Ethernet cable for LAN network.

The most convenient way of connection is recommended. Both ways offer the same operation functions of the controller.

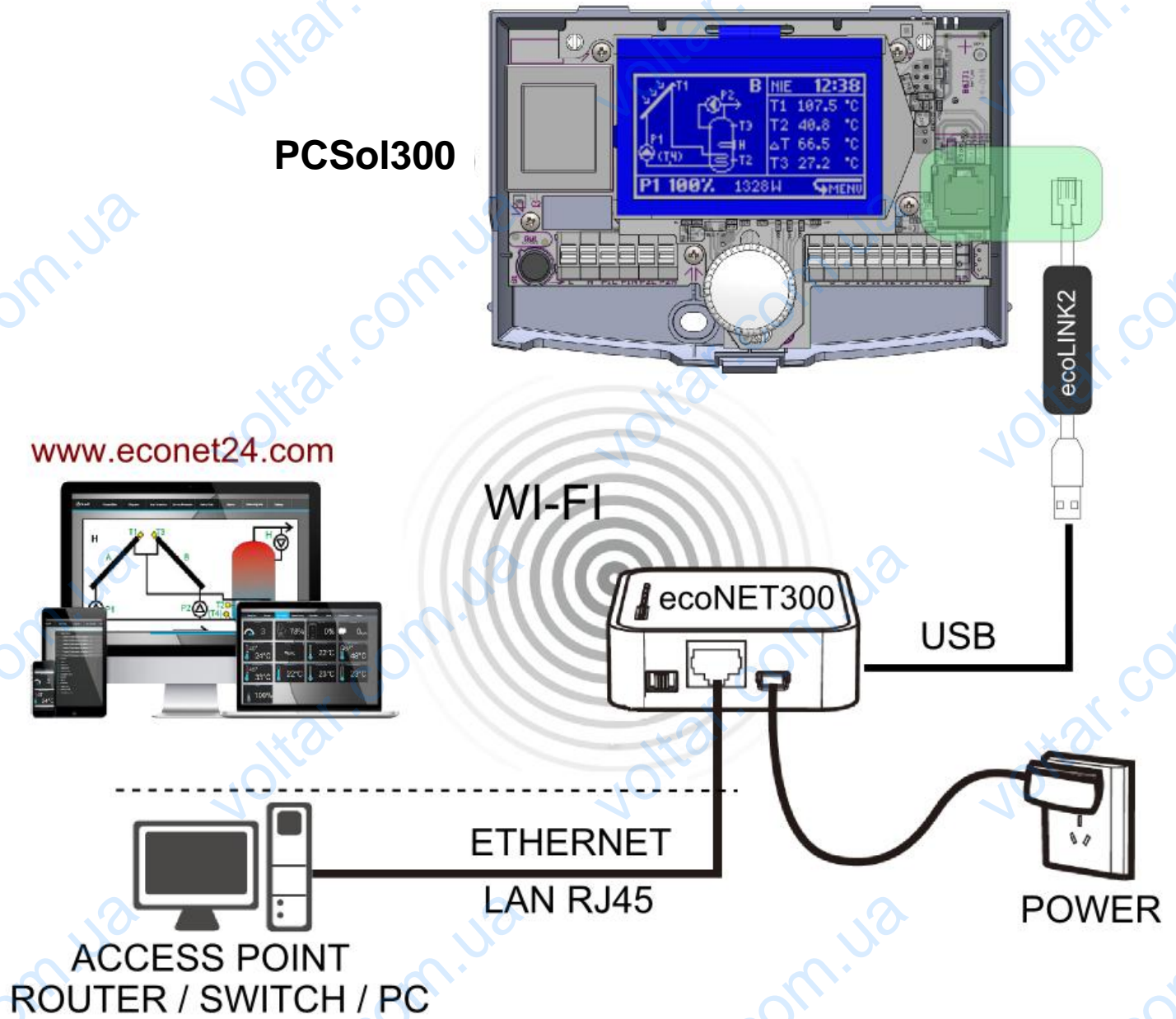

Fig. 17.12 Internet connection structure

18. APPLICATION SCHEMES

18.1. Solar Application scheme A

Loading of DHW reservoir from collector.

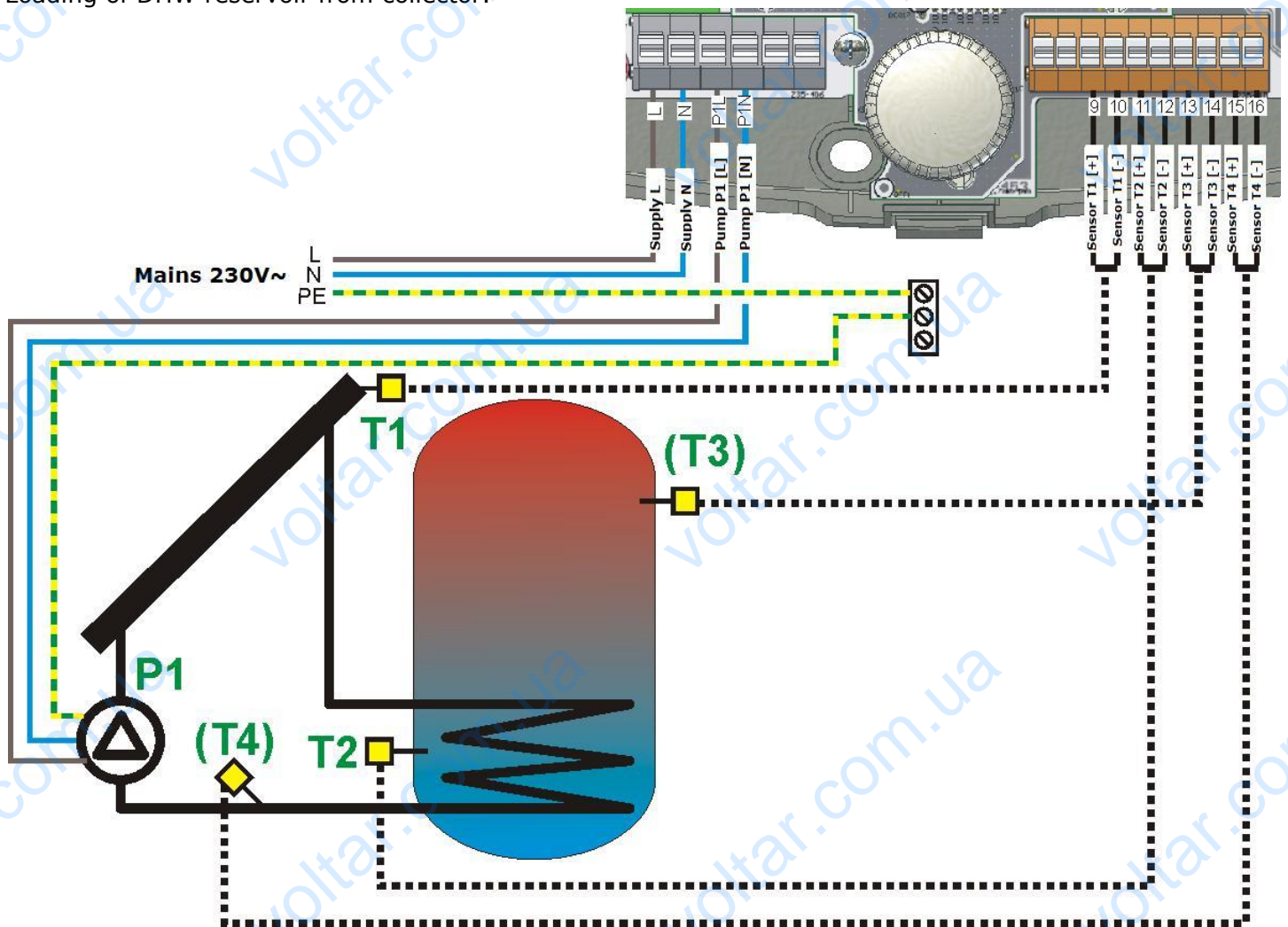

Fig. 18.1 Schemat aplikacyjny A

Installation notes

1. For the controller to count heat output, install additional CT6 sensor on the outlet of lower pipe coil from DHW reservoir and connect to **T4** input (or **T3** for **Basic**). The sensor must be installed possibly near the connector pipe.
2. **T3** sensor shows temperature in upper part of the reservoir, its connection is not required. In **Basic** version it is used only for heat output counting.

18.2. Solar Application scheme B

Loading of DHW reservoir from solar panel with additional function of extra heating with a heater, when the solar panel stops supplying energy and with control of **DHW** circuit with circulation pump.

In this layout, it is required to connect **T3** sensor and it must be installed in the reservoir over a heater. If **T3** is disconnected from the controller or damaged, it will disable reservoir extra heating function.

How to connect **H** output to a heater via a relay is presented in details in section 17.2.5.

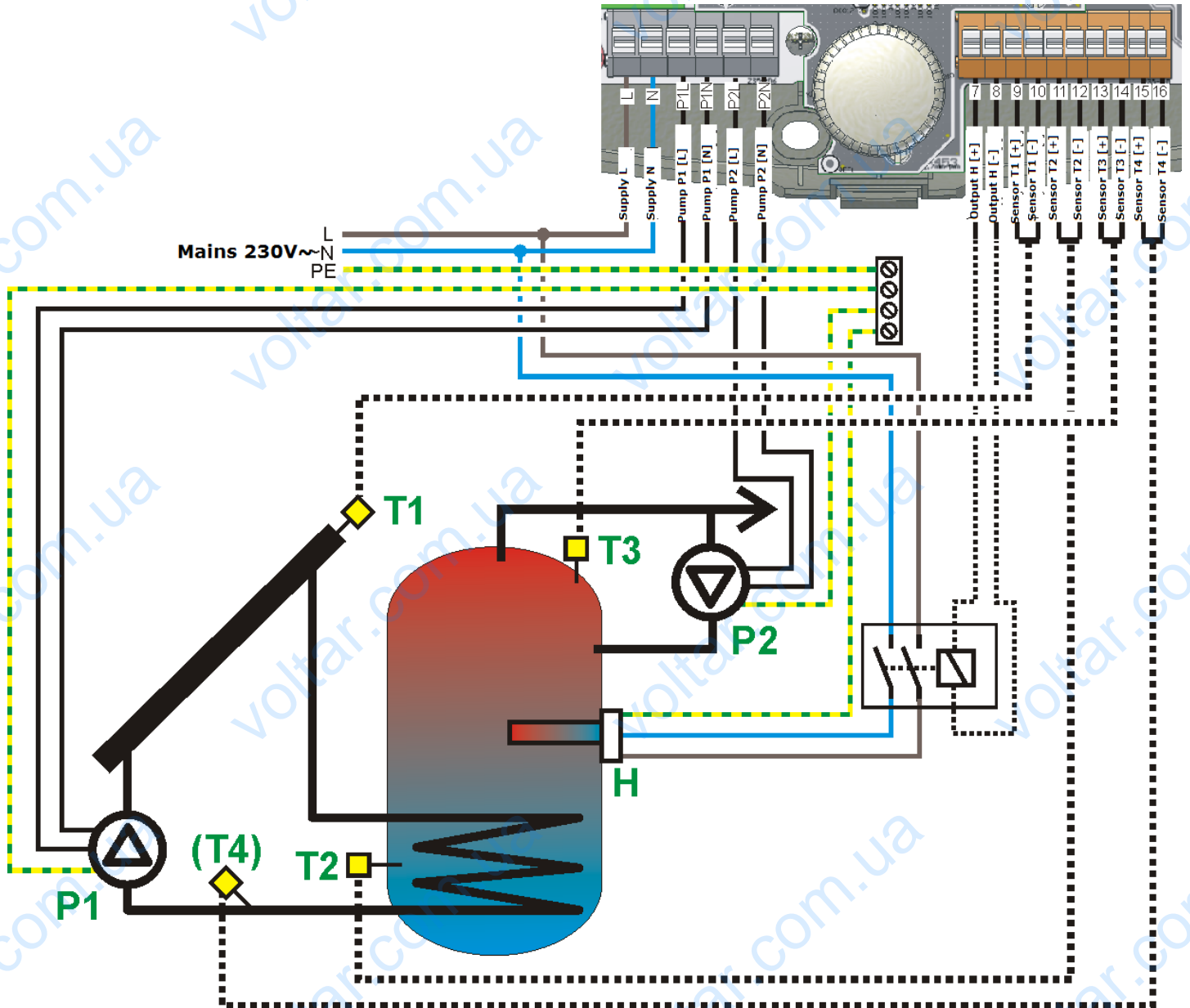

Fig. 18.2 Application scheme B

Installation notes

1. For the controller to count heat output, install additional CT6 sensor on the outlet of lower pipe coil from DHW reservoir and connect to **T4** input. The sensor must be installed possibly near the connector pipe.
2. **T3** sensor is used for controlling additional heat source (**H** output). Disconnection of the sensor will disable **H** output and the algorithm of the reservoir loading from collector will work normally.

18.3. Solar Application scheme C

Loading of DHW reservoir from a solar panel with additional function of heat discharge to drain system, when the reservoir maximal temperature (**TDHW_{max}**) is exceeded.

In this layout, **T3** sensor is optional and its connection is not required.

Electro-valve must be connected to **P2** pump outlet.

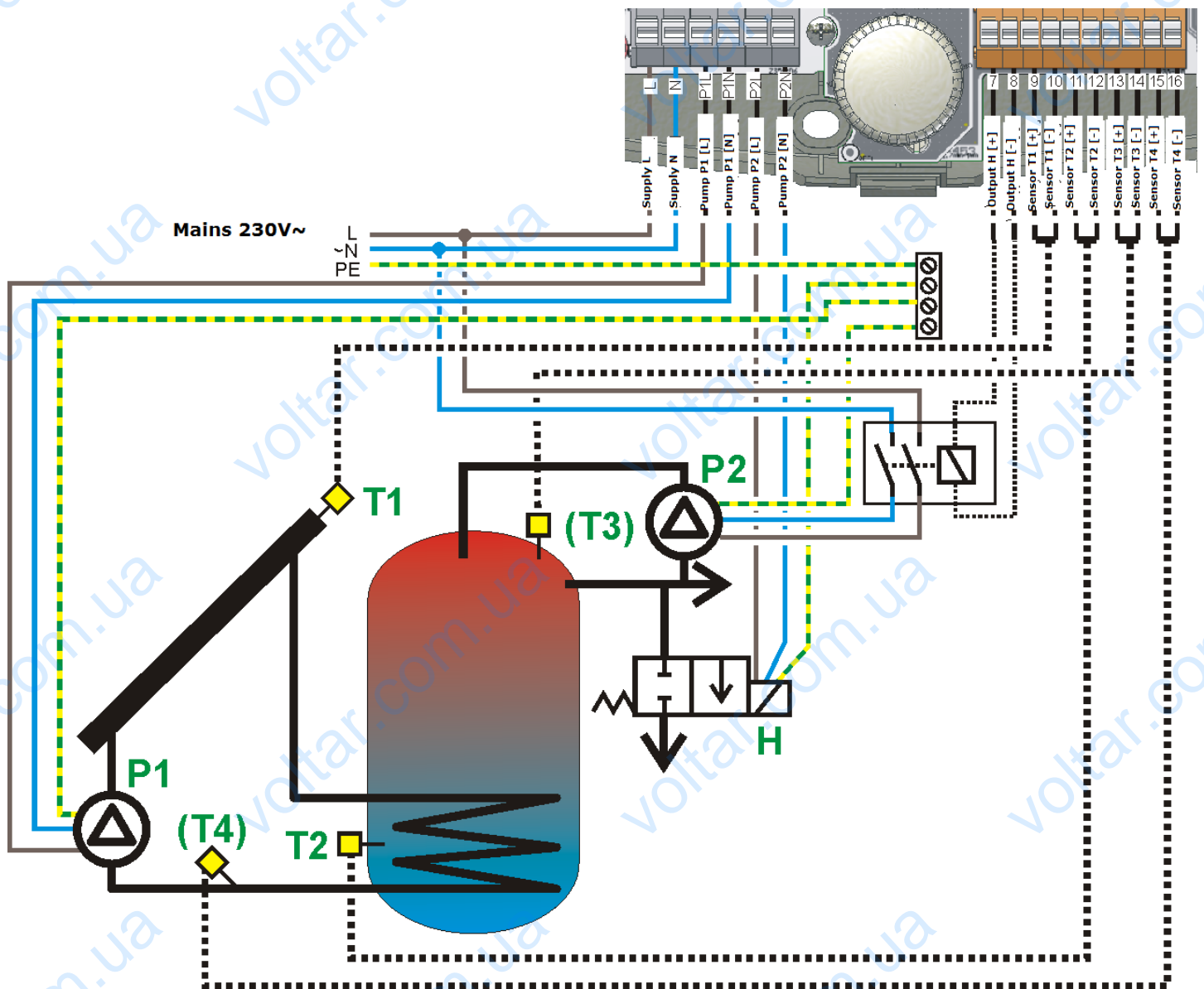

Fig. 18.3 Application scheme C

Installation notes

1. For the controller to count heat output, install additional CT6 sensor on the outlet of lower pipe coil from DHW reservoir and connect to **T4** input. The sensor must be installed possibly near the connector pipe.
2. **T3** sensor shows temperature in upper part of the reservoir, its connection is not required.
3. Circulation pump is connected to **H** output through a relay with contact current not lower than the current of the circulation pump. It is recommended to use relays with two switching tracks, see details in section 17.2.5 Output H output.
4. Discharge valve coil connected to P2 output must be adjusted to ~230 voltage, see fig. Fig. 18.3, otherwise the valve should be controlled indirectly by an additional transmitter.

Setting notes

1. Heat discharge valve works until **T2** drops below **TDHW_{max}-HP2**. Do not set **HP2** value too high as this result in large heat discharges.

18.4. Solar Application scheme D

Loading of DHW reservoir from a solar panel and transfer of accumulated heat to the reservoir **B**.

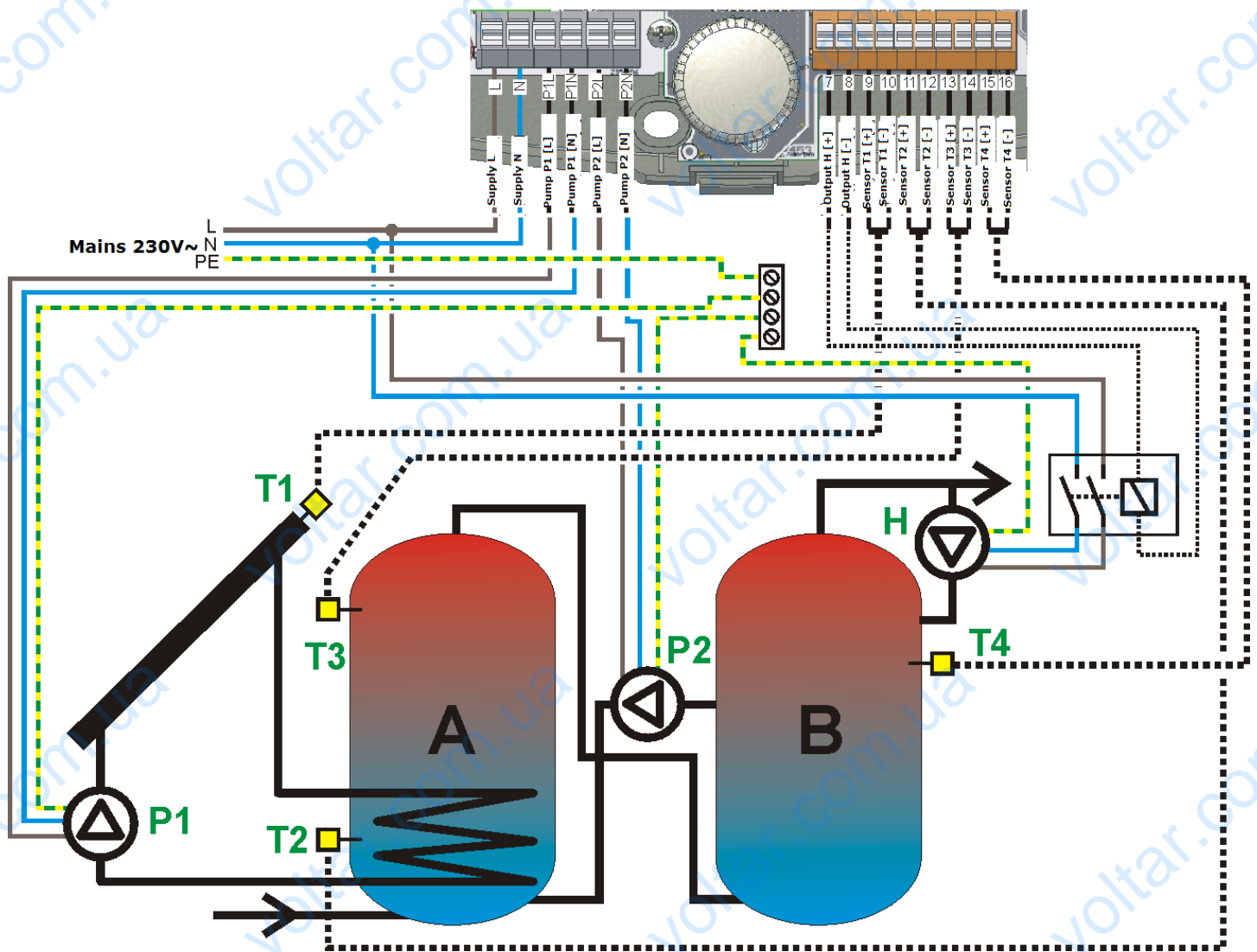

Fig. 18.4 Application scheme D

Installation notes

1. This scheme requires two additional CT6 sensors.
2. Circulation pump is connected to **H** output through a relay with contact current not lower than the current of the circulation pump. It is recommended to use relays with two switching tracks, see details in section 17.2.5 Output H.

Setting notes

1. Do not set **HP2** value higher or equal to **dTAB**, because this will prevent loading stop when **dTAB** value is reached.
2. With respect to **night cooling mode** used for the reservoir **A** and circulation activation for better discharge of the container, it is recommended that circulation circuit is installed in the reservoir **A**.

18.5. Solar Application scheme E

Loading of two **DHW** reservoirs (**A** and **B**) with loading priority for reservoir **A**.

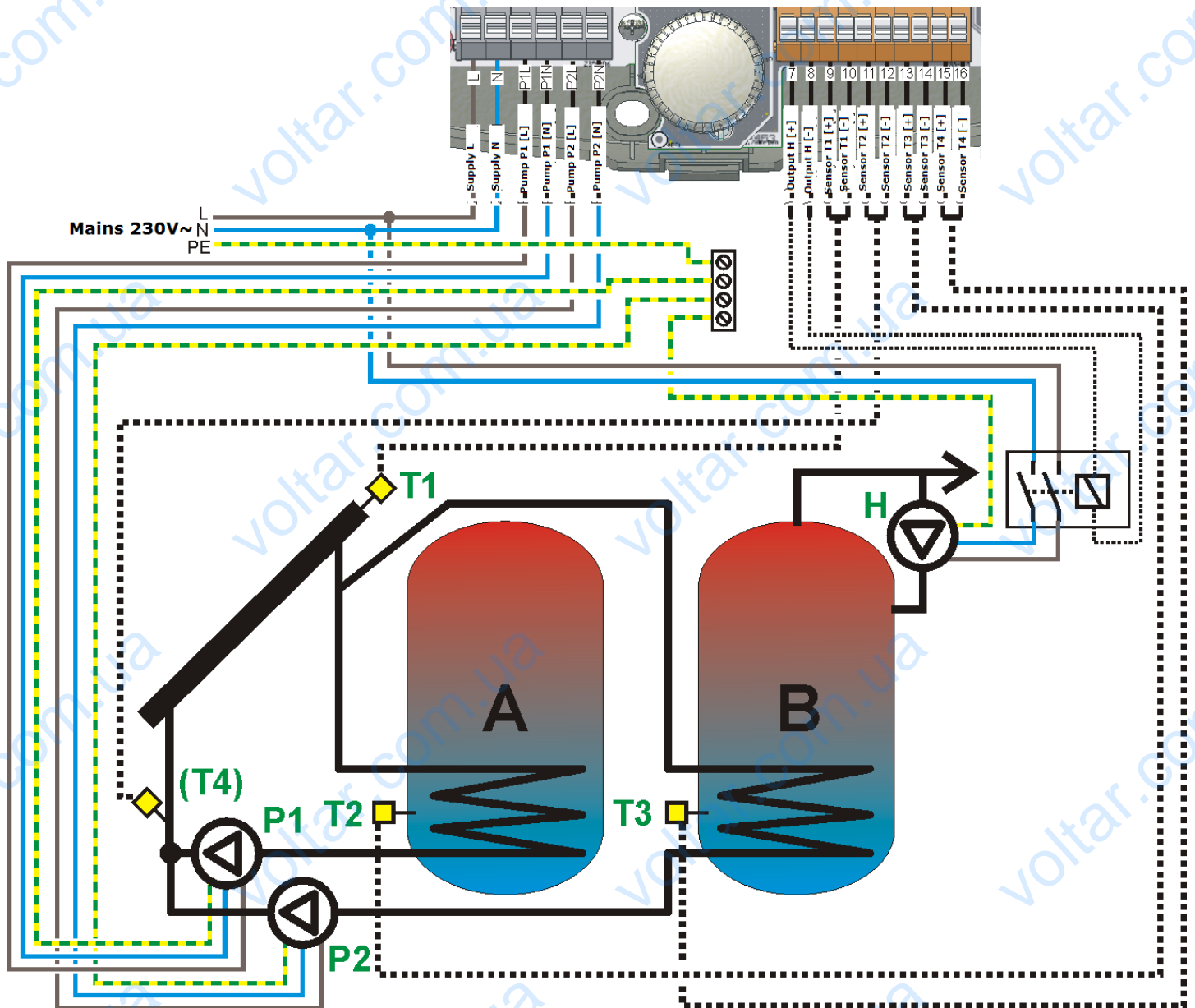

Fig. 18.5 Application scheme E

Installation notes

1. For the controller to count heat output, it is required to install additional CT6 sensor outside circuits of pumps **P1** and **P2** and connect it to **T4** input. The sensor should be installed possibly close to the **P1** and **P2** pump outlet.
2. Circulation pump is connected to H output through a relay with contact current not lower than the current of the circulation pump. It is recommended to use relays with two switching tracks, see details in section 17.2.5 Output H.
3. In the diagram the circulation pump is located on **B** tank, but its operation is not related with the algorithm and it may be installed on **A** tank as well.
4. With respect to night cooling mode used for the reservoir A and circulation activation for better discharge of the container, it is recommended that circulation circuit is installed in the reservoir A.

18.6. Solar Application scheme F

Heating of DHW reservoir and pool with Priority function.

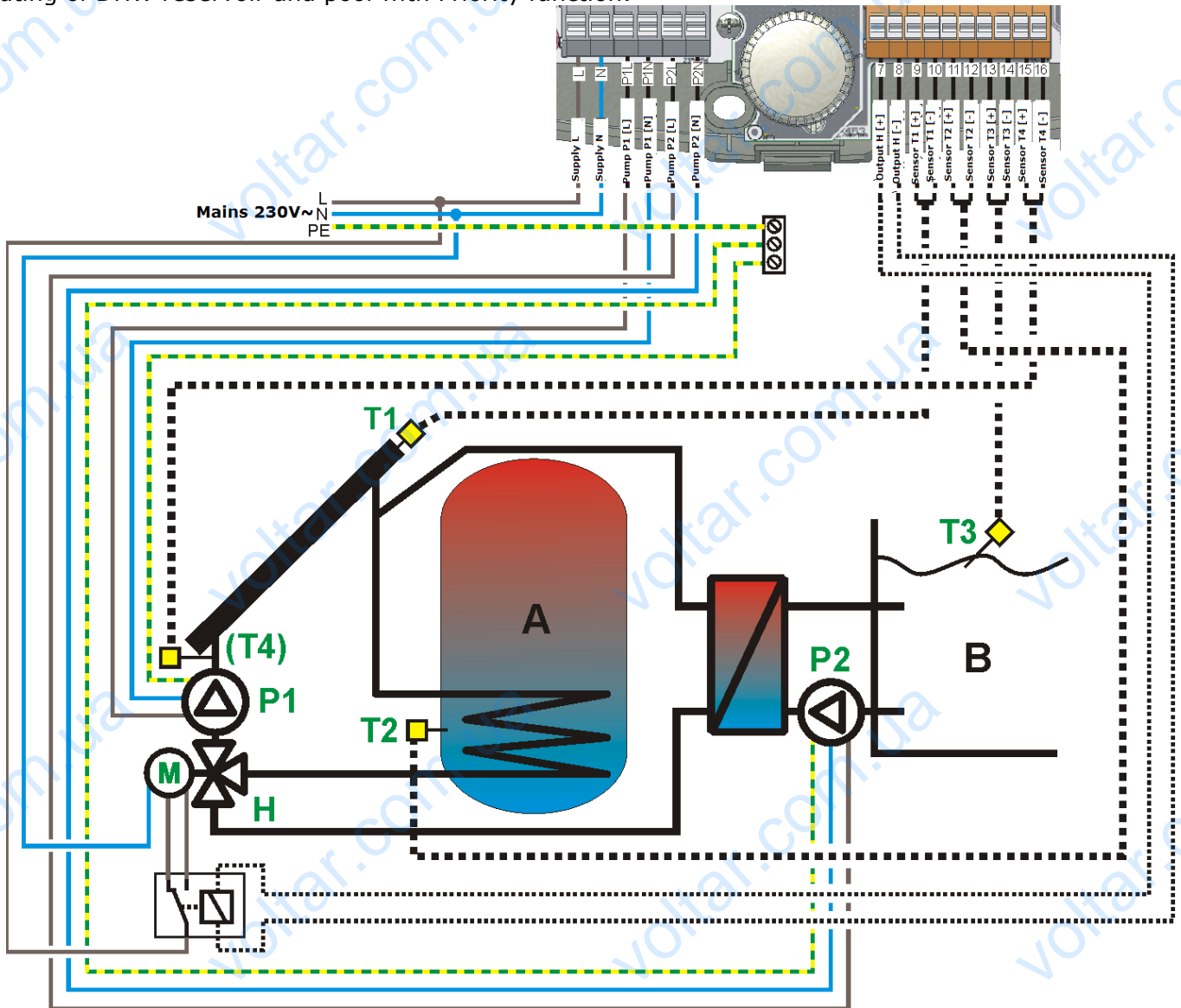

Fig. 18.6 Application scheme F

Installation notes

1. For the controller to count heat output, install additional CT6 sensor outside circuits of three-way valve **H** and connect it to **T4** input. The sensor should be installed possibly close to the **H** outlet.
2. The valve should be connected so that the controlled relay connected to output **H** (H=ON) set will set the valve in pool loading position. Reverted connection will damage the system.

Setting notes

1. If the used three-way valve has switching time longer than 120sec, set maximal value for **tVALUE**.
2. If the used three-way valve has near zero switching time, set minimal value for **tVALUE**.
3. When the circuits are being switched (**tVALUE** time) the collector pump is not working and the circuit receives no heat. Pay attention to collector heat up time and if required set shorter **tVALUE** time.
4. During anti-freeze function, the exchanger pump will work longer than the collector pump by double **tDLY** time. So select this parameter value that after **P2** is stopped, the temperature of glycol in exchanger is not lower than 0°C, as it may damage the exchanger. If there is a risk that such situation may happen, switch off antifreeze function for the pool system.



Antifreeze function in pool circuit (with priority) may be used only at high awareness. Wrong settings or unfavorable conditions may damage the exchanger. Always consider all factors like, e.g., solar work fluid with below-zero temperature in the exchanger.

18.7. Solar Application scheme G

Loading of DHW reservoir with solar collector and boiler.

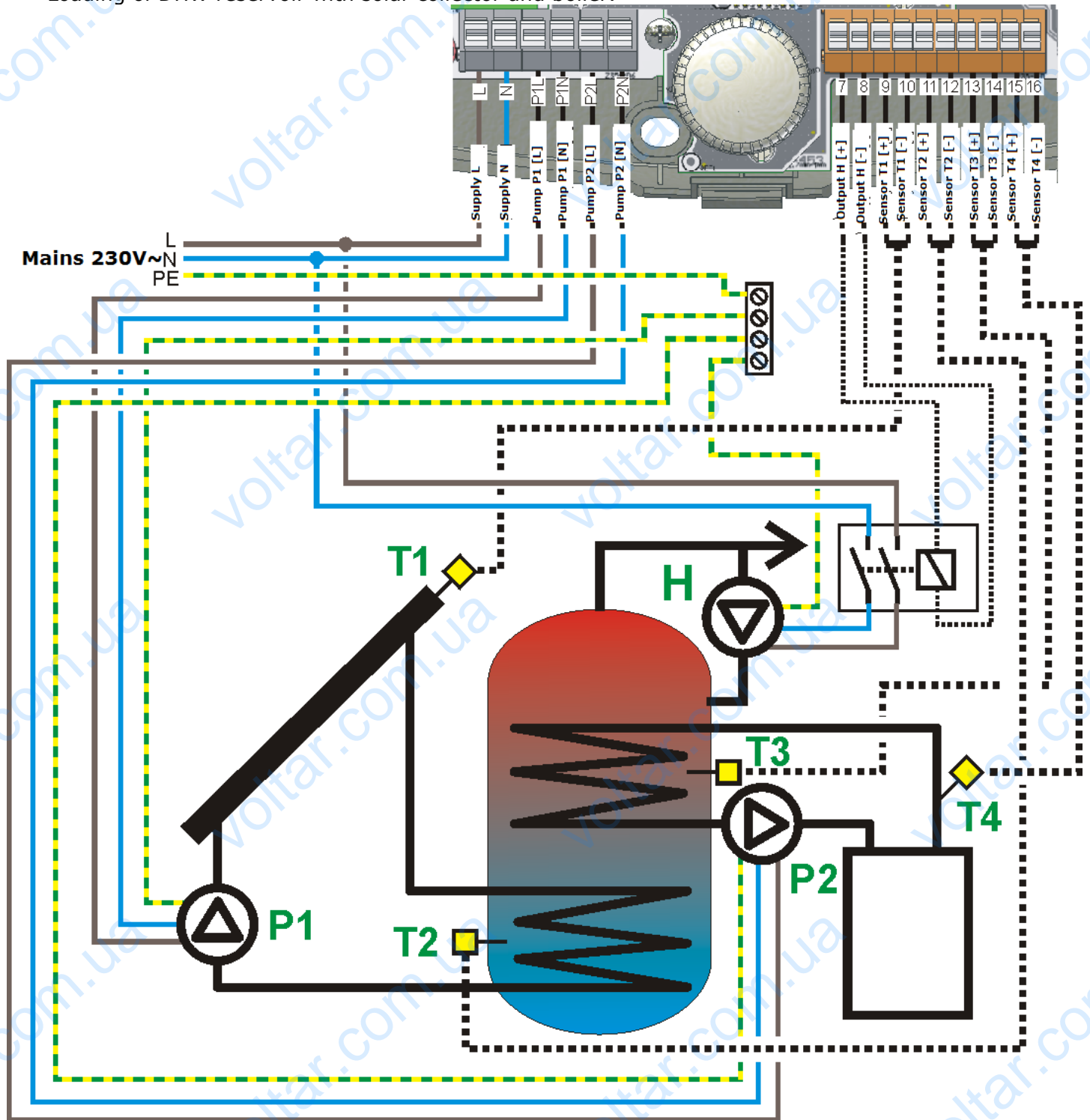

Fig. 18.7 Application scheme G

Installation notes

1. Circulation pump is connected to H output through a relay with contact current not lower than the current of the circulation pump. It is recommended to use relays with two switching tracks, see details in section 17.2.5 Output H.

18.8. Solar Application scheme H

Loading of DHW reservoir from two sets of solar collectors oriented in two directions.

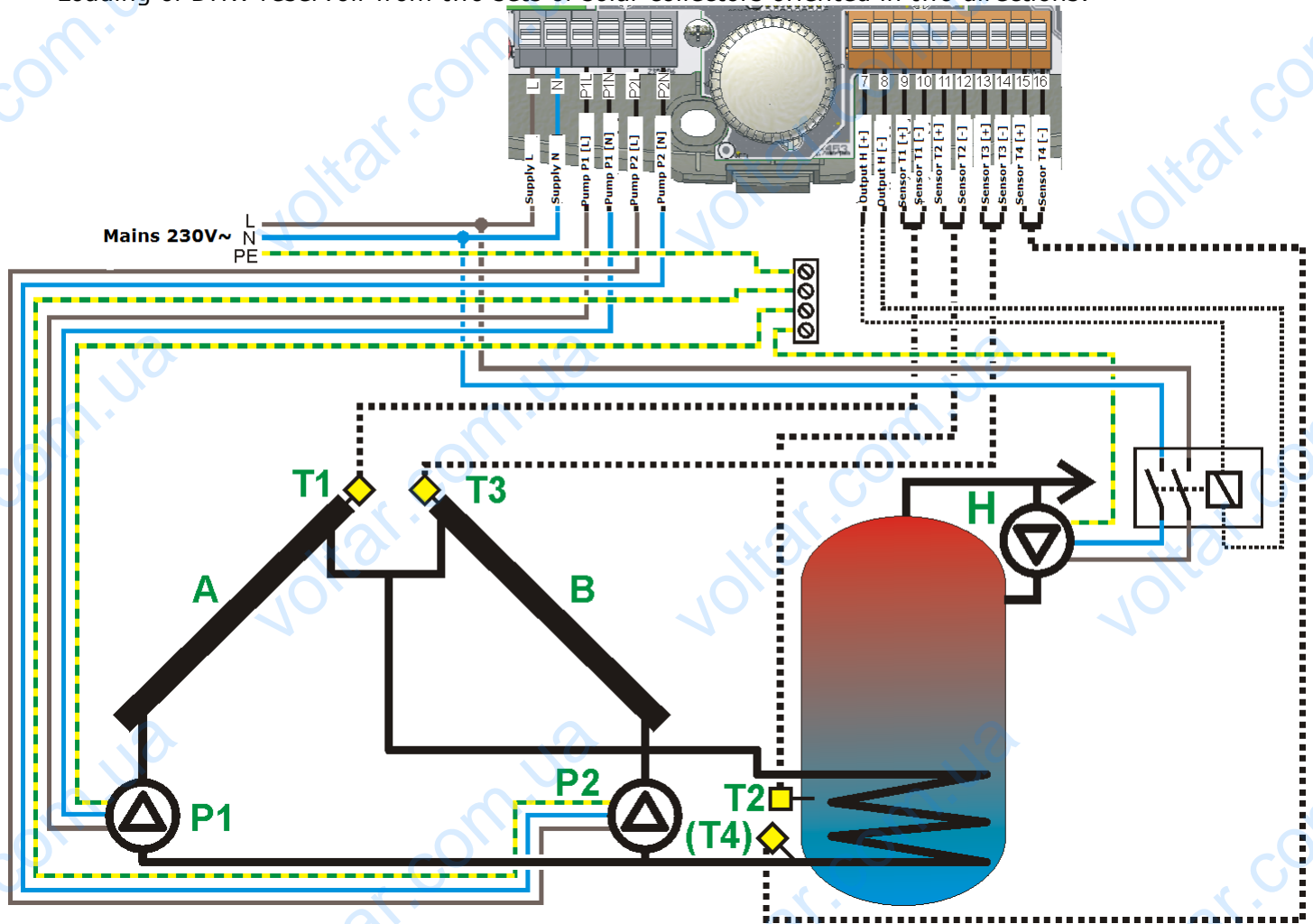

Fig. 18.8 Application scheme H

Installation notes

1. For correct operation the system must be equipped with return valves mounted on the solar panel outlets. In other case, starting circuit of **A** collector will affect operation of **B** collector sensor, causing poor performance.
2. For the controller to count heat output, install additional CT6 sensor on DHW reservoir lower pipe coil and connect it to **T4** input. The sensor must be installed possibly near the connector pipe.
3. Circulation pump is connected to H output through a relay with contact current not lower than the current of the circulation pump. It is recommended to use relays with two switching tracks, see details in section 17.2.5 Output H.

Setting notes

1. With the use of additional sensor **T4**, the controller allows effective controlling of **P2** pump that will be started, when the temperature of return from exchanger reaches **dTP2** value.

18.9. Solar Application scheme I

Loading of pool system from solar collector.

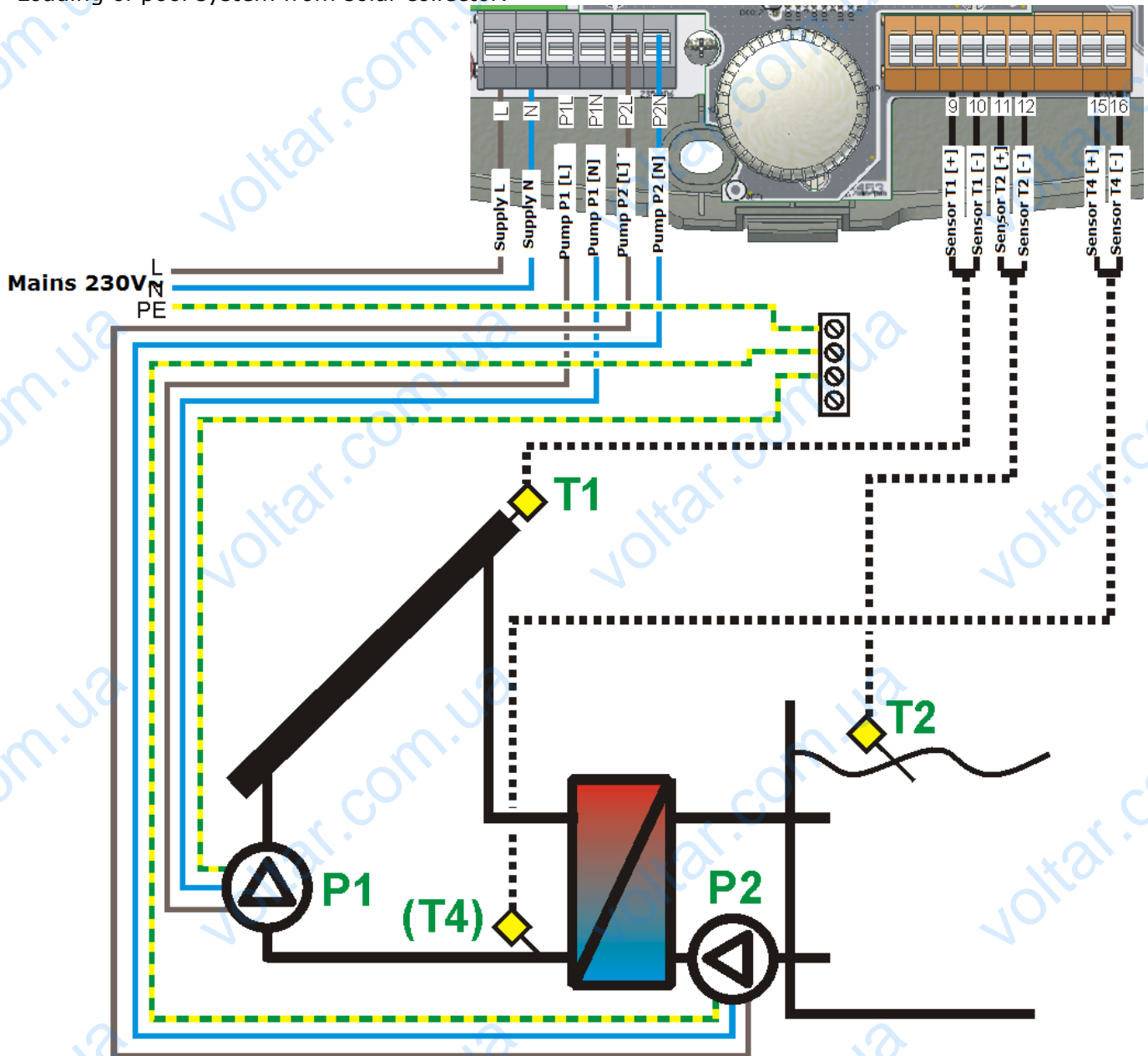

Fig. 18.9 Application scheme I

Installation notes

1. For the controller to count heat output, it is required to install additional CT6 sensor directly on the return from the pool exchange, and connect it to **T4** measurement input.

Setting notes

1. With the use of additional **T4** sensor, the controller allows effective controlling of **P2** pump that will be started, when the temperature of return from exchanger reaches **dTP2** value.
2. At long pipe lengths (between collector and exchanger), setting of **dTP2** value lower than it results from losses incurred in the collector-exchanger section will prevent starting of **P2** pump, even at high temperatures in the collector. This setting must be selected specifically to each installation.
3. During anti-freeze function, the exchanger pump will work longer than the collector pump by double **tDLY** time. So select this parameter value that after **P2** is stopped, the temperature of glycol in exchanger is not lower than 0°C, as it may damage the exchanger. If there is a risk that such situation may happen, switch off antifreeze function for the pool system.



Antifreeze function in pool circuit (with priority) may be used only at high awareness. Wrong settings or unfavorable conditions may damage the exchanger. Always consider all factors like, e.g., solar work fluid with below-zero temperature in the exchanger.

18.10. Solar Application scheme J

Collector operation with additional back-up source.

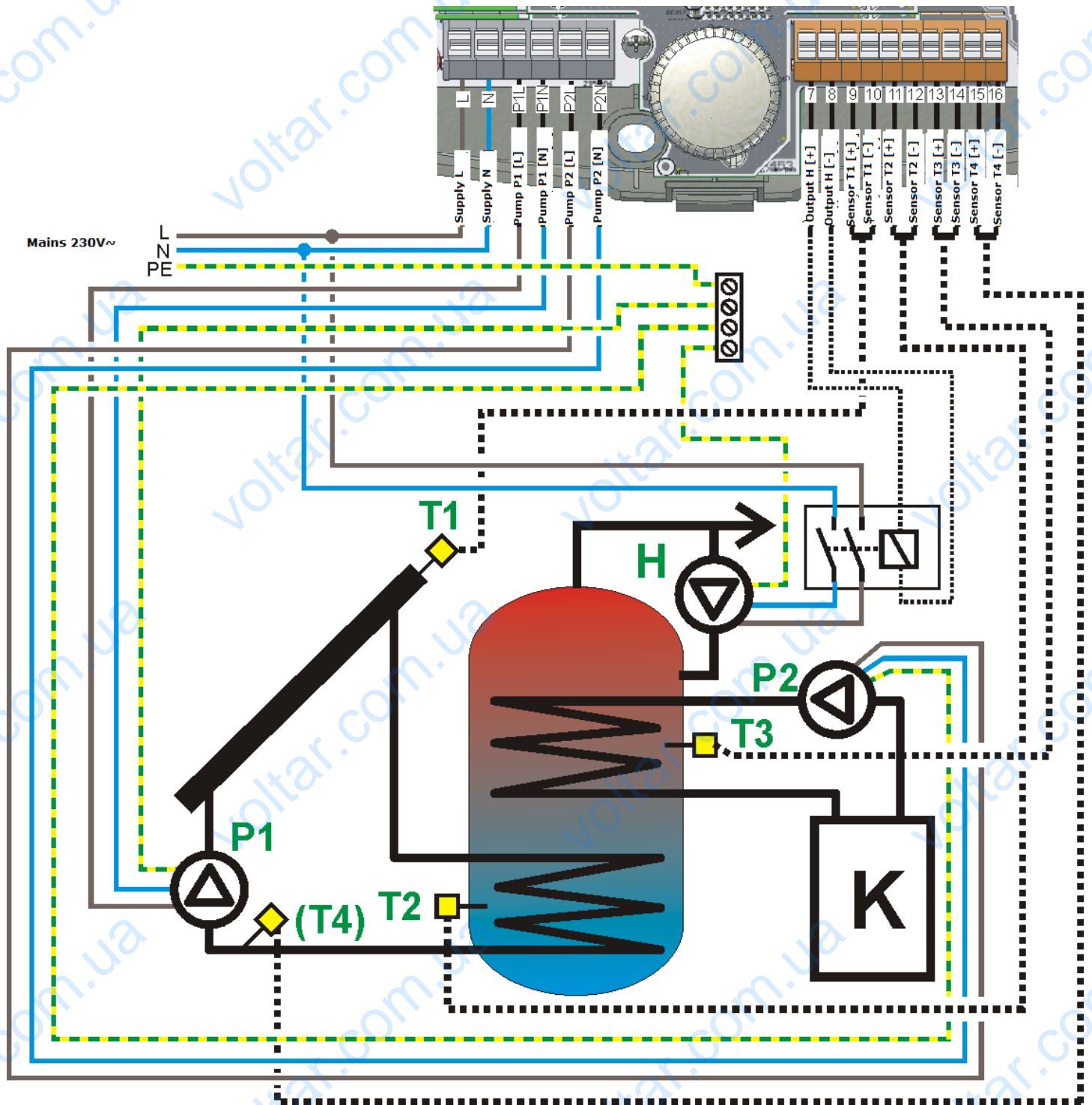

Fig. 18.10 Application scheme J

Installation notes:

1. For the controller to count heat output, it is required to install additional CT6 sensor directly on the return from the DHW reservoir lower pipe coil and connect it to T4 measurement input.
2. Circulation pump is connected to H output through a relay with contact current not lower than the current of the circulation pump. It is recommended to use relays with two switching tracks, see details in section 17.2.5 Output H.

18.11. Solar Application scheme K

Charging A Buffet with a solar panel. „Container-in-container“ type buffer. The regulator supports CH system.

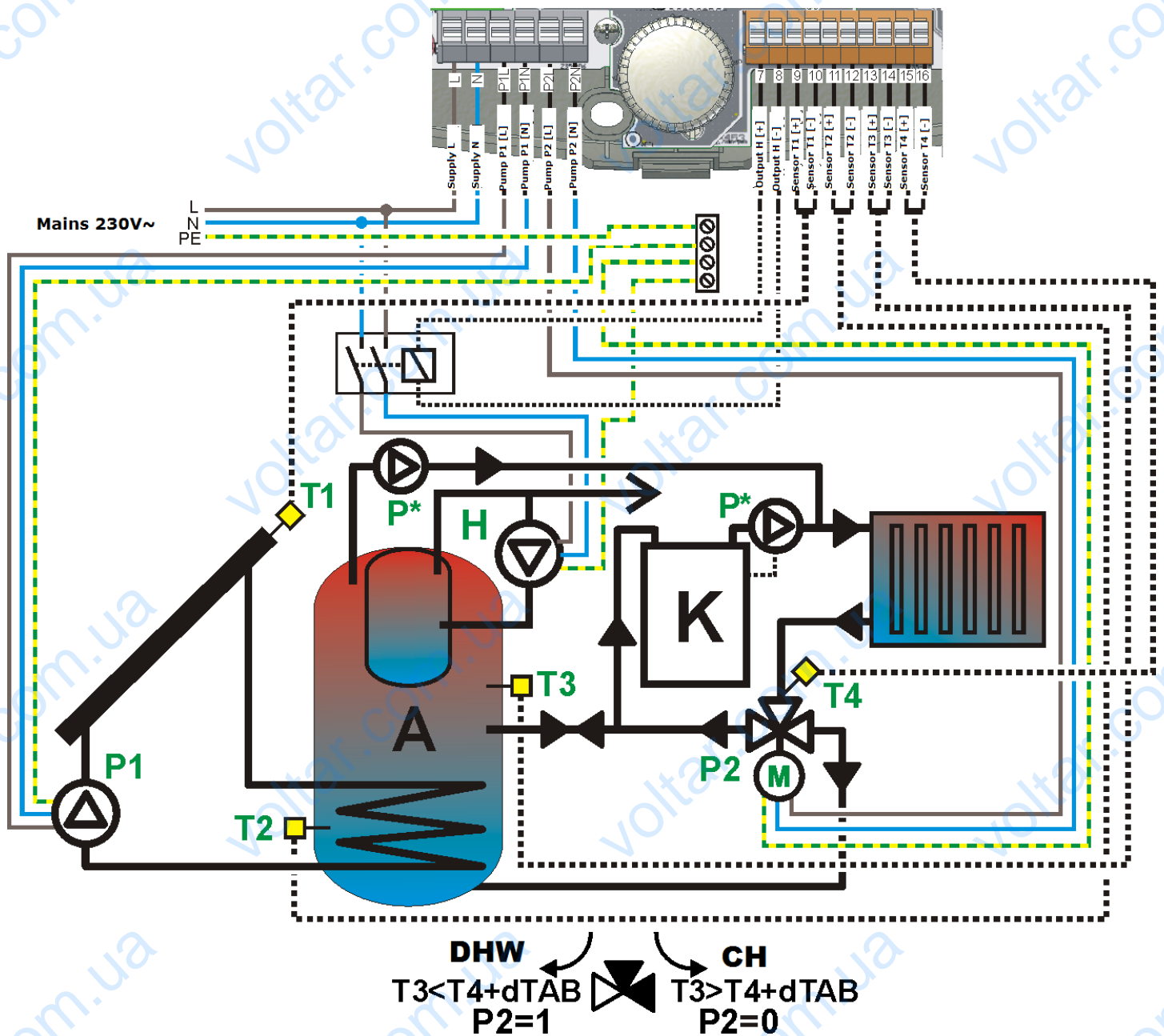

Fig. 18.11 Application scheme K

*Pumps marked in the scheme as P are not controlled by BLUESol 02 regulator.

Installation instructions

1. Two additional CT6 sensors are required for the application schema.
2. Connect the circulation pump to **H** output via a transmitter with connector voltage not lower than circulation pump voltage. It is recommended to use transmitters with two switching circuits. Details can be found in chapter 17.2.5 Connecting H output.

Setting notes

1. Do not set **HP2** value higher or equal to **dTAB**, because this will prevent loading stop when **dTAB** value is reached.

18.12. Aplikacja schemat solarny L

DHW tank is loaded by two solar collector sets oriented towards two points of compass using one pump group and collector circuit switching valve.

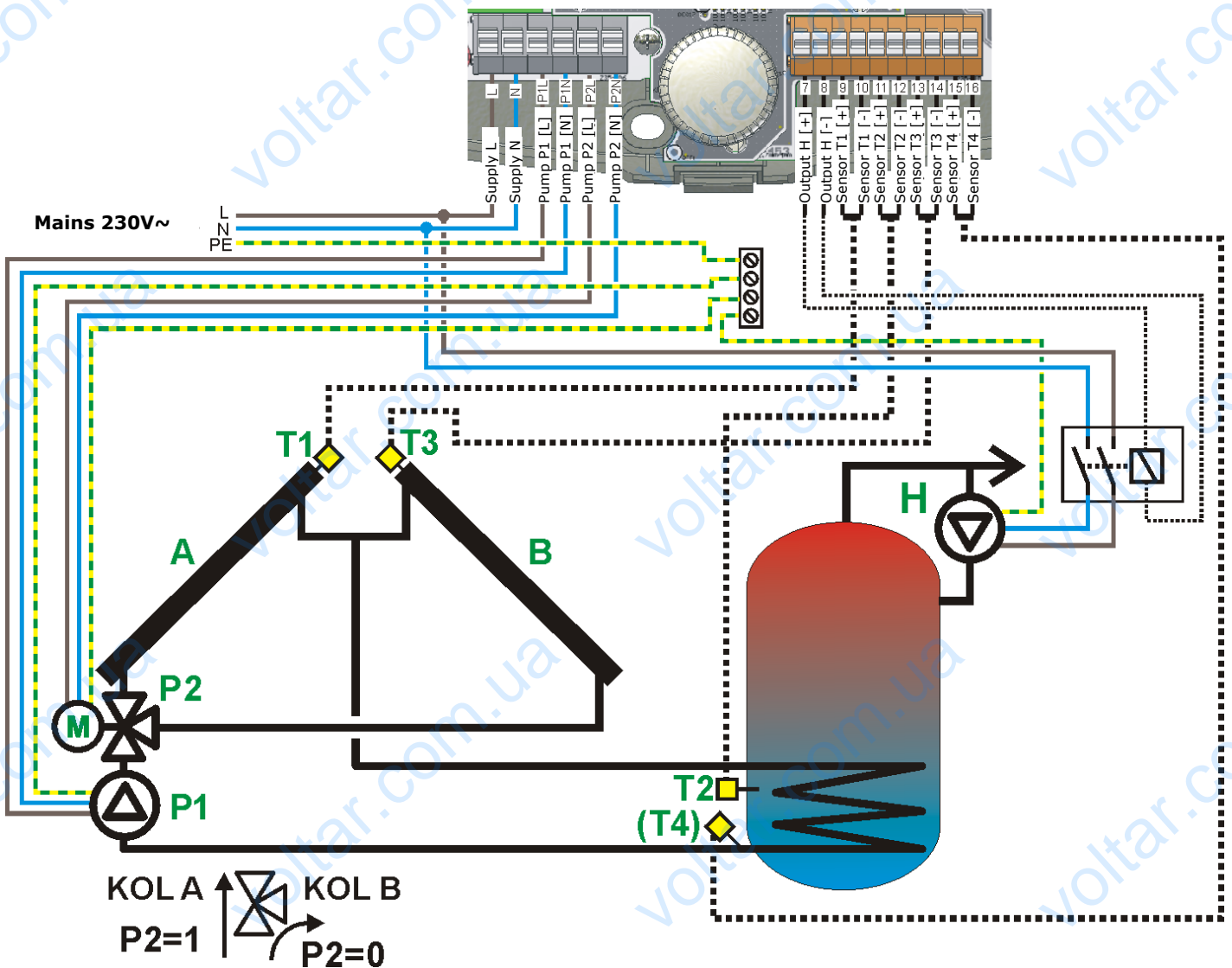



Fig. 18.12 Application scheme L

Installation notes

- 3-way/1-way control valve was considered in this diagram. Valve is switched back by means of a spring. Other valves may be controlled using relays as shown in Fig. 17.11
- The valve should be so installed that high state of P2 output sets the flow in direction of A-solar collector.
- The valve may be connected to solar collector supply.  Valve way is as shown in item 2.
- To enable calculation of heat yield by the regulator: install additional CT6-type sensor at the outlet of lower pipe coil from DHW tank and connect it to **T4** input. The sensor should be mounted as close as possible to the outlet of pipe coil from DHW tank.
- Connect circulating pump to **H**-output through relay of contact current not less than the current of the pump. It is recommended to use relays with two switching channels – for details see section 17.2.5 *Output H*.
- Setting recommendations
- During interim periods, when sunlight falls on both solar collectors and the collector currently not in use becomes overheated, reduce the set tOP time.

19. CASING CLOSING

To close the unit casing hook the casing cover with recesses against the base insets (shown in Fig. 19.1)

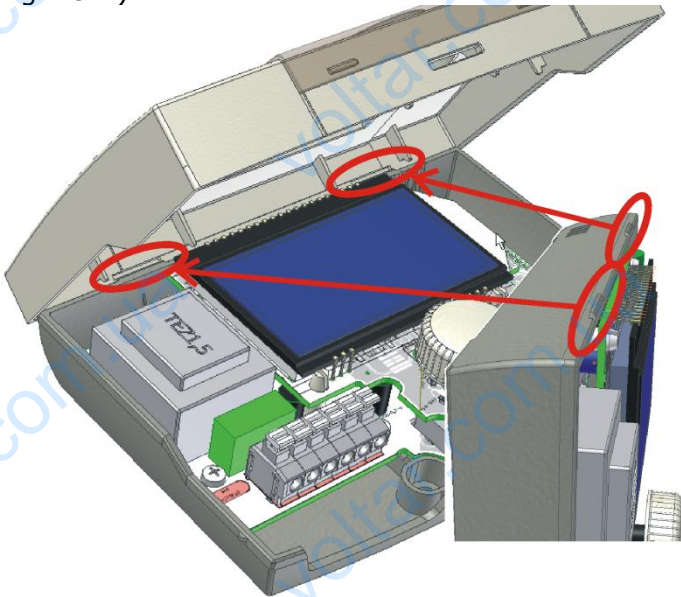

Fig. 19.1 Casing closing first step

Then, press the cover in place indicated by red arrow (Fig. 19.2), until you clearly hear the latch click.



Fig. 19.2 Casing closing second step

20. CONTROLLER OPTIONS

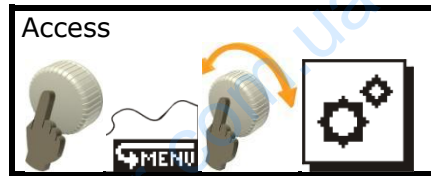

Access to the controller options is protected with password and to make any changes you must log-in with a service password.



Fig. 20.1 User login screen

To login place cursor in selected digit by its rotating, then press the button. When the digit is blinking, rotate the encoder to change its value. Confirm the digit by pressing again. Edition will move the cursor to next position. Confirm login by using "OK" or abandon login by using "CANCEL" option. If the password is wrong, the unit will display a message Fig. 20.2.

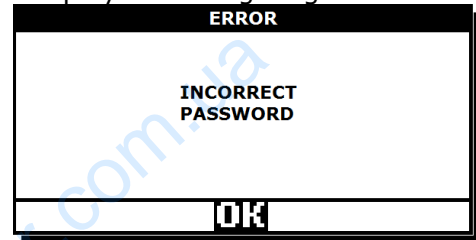

Fig. 20.2 Information on incorrect password

Repeat login procedure.



Settings should be modified only by trained persons with adequate technical skills. Wrong parameters may cause irregular performance or damage to the equipment.

20.1. System Options\Settings

The following settings are available depending on scheme and version:

Setting	PCSol 300											
	A	B	C	D	E	F	G	H	I	J	K	L
dTonDHW	X	X	X	X	X	X	X	X		X	X	X
dToffDHW	X	X	X	X	X	X	X	X		X	X	X
dTonPOOL						X			X			
dToffPOOL						X			X			
TCOLmin	X	X	X	X	X	X	X	X	X	X	X	X
TCOLcr	X	X	X	X	X	X	X	X	X	X	X	X
TCOLmax	X	X	X	X	X	X	X	X	X	X	X	X
TDHWmax	X	X	X	X	X	X	X	X		X	X	X
Pmin	X	X	X	X	X	X	X	X	X	X	X	X
tP	X	X	X	X	X	X	X	X	X	X	X	X
HP1	X	X	X	X	X	X	X	X	X	X	X	X
HP2	X	X	X	X	X	X	X	X	X	X	X	
tVALVE						X						
tDLY						X			X			X
TCOmin							X					
dTP2									X			

Settings description

dTonDHW - temperature difference between **T1** (**T3** in scheme **H**) and **T2** (**T3** in scheme **E**) that will the collector pump **P1** or **P2** at 100% capacity.

dToffDHW - temperature difference between **T1** (**T3** in scheme **H**) and **T2** (**T3** in scheme **E**), at which the pump will work with minimal capacity **Pmin**. Below this value, the collector pump is stopped. It will be restated when **dTonDHW** value is reached.

dTonPOOL - in schemes with pool system, temperature difference between **T1** and **T3** (for scheme **F**) and **T1** and **T2** (for scheme **I**), which starts **P1** pump at 100% capacity.

dToffPOOL - temperature difference between **T1** and **T3** (for scheme **F**) and **T1** and **T2** (for scheme **I**), at which the pump will work with minimal capacity **Pmin**. Below this value, the collector pump is stopped. It will be restated when **dTonPOOL** value is reached.

TCOLmin - minimal collector temperature, which must be reached to allow reservoir loading. If the collector temperature has not reached this setting value, despite that loading conditions are met (resulting e.g. from reaching **dTon**) the controller would not start the collector pump.

The collector pump will be started only below **dToffDHW** or **dToffPOOL** (depending on scheme).

TCOLcr - collector critical temperature. Temperature which regardless of reaching reservoir preset (**TsDHW**) or pool preset (**TsPOOL**) will start the collector pump at 100% capacity in order to discharge heat from the collector. It will be stopped when the collector temperature drops below **TCOLcr-HPx** (where x means the number of collector pump: **1** or **2**). If **AlarmTCOLcr** setting has **YES** value, the unit displays alarm on exceeding critical collector temperature. This alarm allows starting collector pump, only when the system with **DHW** reservoir is not in condition of exceeded reservoir maximal temperature **TDHWmax** alarm.

TCOLmax - reaching this collector temperature will stop the collector pump. The controller reports alarm. The collector pump may be started only when the collector temperature drops below the temperature difference **TCOLmax-HPx**.



The controller dynamically limits minimal value of **TCOLmax** setting and maximal value of **TCOLcr** setting, so that set values give interval between **TCOLcr** and **TCOLmax** not lesser than 30°C. This protects from impulse increase of the collector temperature when the collector pump is started, after **TCOLcr** is reached. To set higher **TCOLcr** than allowed by the controller, increase **TCOLmax** value, so that the interval condition of 30°C is maintained.

- DHW reservoir maximal temperature that stops collector pump and disables further loading of the reservoir. Alarm on exceeding DHW reservoir maximum temperature is displayed. This alarm has higher priority than alarm on **TCOLcr** and despite the alarm on collector critical temperature; the controller will disable starting the collector pump for the reservoir. Alarm will be stopped and the pump start released, when the reservoir temperature drops below **TDHWmax-HPx**.

Pmin - minimal capacity of the collector pump reached if the difference between collector and reservoir temperatures drops to **dToffDHW** or **dToffPOOL** value (depending on scheme).

tP – Minimal time of the collector pump work. If the difference between collector and reservoir temperatures drops to **dTon**, the collector pump will be started for the time of **tP**.

HP1- auxiliary hysteresis for **P1** output.

HP2 - auxiliary hysteresis for **P2** output.



*Too high values of **HP1**, **HP2** settings may lead to large temperature oscillations in the system, so it is recommended to leave them at the level of 1°C.*

tVALVE – minimal operation time of the controller's valve that switches the circuits (used in solar application **F**).

tDLY – time of delay for switching on/off the pump downstream heat exchanger.

TCOmin – minimal temperature in **CH** circuit (measured by **T4** sensor) in scheme **G**, which allows loading of DHW reservoir from the boiler system. Below this temperature (even if there are conditions for reservoir loading, i.e. **TsDHW** is lower than preset or **dTCO** is reached), the controller will disable the reservoir loading. This prevents **CH** circuit operation below the boiler's dew point.

dTP2 – temperature difference between **T1** collector and **T4** exchanger, if reached the controller will start exchanger pump in scheme **I**. Operation with **tDLY** is also possible, then **dTP2** setting must set as **OFF**. At such setting, the controller will run **P2** operational algorithm with delay of **tDLY** in relation to **P1** pump operation. Alarm from **T4** sensor will not be reported.

20.2. I\O Options\Configuration

Depending on the length of sensor extension cable, sensors will show temperature without taking into account resistance of connection lines. To compensate cable effects, it is required to perform sensor compensation procedure.

20.2.1. Wire length compensation

It consists in measurement of wires connected to a sensor (measurement track), reading value from the compensation table for connecting wire resistance, and programming this value in the controller.

The controller will automatically move sensor's characteristics to compensate the effect of additional resistance.

When you enter menu, the controller displays current values of temperature corrections.

If the controller displays 0.0, it means that no correction has been introduced for given track.

To clear any compensation data for the track, enter 0.0 value.

The procedure may be conducted using ohmmeter to measure resistance of both cable conductors and selecting from the table respective value for measured resistance.

If received result indicates correction above 2°C, it may mean that the cable has resistance bigger than permissible or that they are too long.

Table of cable lengths and resistance.

size length	0,5mm ²	0,75mm ²	1mm ²
5m	0,35Ω 0,1°C	0,23Ω 0,1°C	0,18Ω 0,1°C
10m	0,69Ω 0,2°C	0,46Ω 0,2°C	0,35Ω 0,1°C
15m	1,04Ω 0,3°C	0,69Ω 0,2°C	0,52Ω 0,2°C
20m	1,38Ω 0,4°C	0,92Ω 0,3°C	0,69Ω 0,2°C
25m	1,73Ω 0,5°C	1,15Ω 0,3°C	0,87Ω 0,3°C
30m	2,07Ω 0,6°C	1,38Ω 0,4°C	1,04 Ω 0,3°C

20.3. Options\Functions

Depending on scheme and version, the following settings are available in the Functions menu:

Setting	Scheme											
	A	B	C	D	E	F	G	H	I	J	K	L
Antifreeze	X	X	X	X	X	X	X	X	X	X	X	X
Work fluid	X	X	X	X	X	X	X	X	X	X	X	X
Flow P1	X	X	X	X	X	X	X	X	X	X	X	X
Flow P2								X				
Vac. collector	X	X	X	X	X	X	X	X	X	X	X	X
Detect. level	X	X	X	X	X	X	X	X	X	X	X	X
Operation time	X	X	X	X	X	X	X	X	X	X	X	X

Antifreeze – setting **ON** enables the antifreeze function. The collector pump will be started, if the solar work fluid temperature drops to the freezing value set for the work fluid. For correct operation of this function, it is required to select suitable solar work fluid. Collector pump will be stopped, if the work fluid temperature rises by 2°C. When the function is off, the controller will not monitor antifreeze and it may lead to damage of the solar system in winter period, so it is recommended that it remains on. In scheme E, antifreeze function operates in the circuit of reservoir A, in scheme F the function operates in priority circuit. If in the system with **DHW** reservoir the reservoir temperature drops down to 2°C, the

controller will alarm that it is not possible to continue antifreeze function.

Work fluid – type of fluid used in the system. Correct setting is required for good performance of antifreeze function and heat output counting.

No.	Name	Freezing temperature
1	Ergolid EKO -15°C	-15°C
2	Ergolid EKO -20°C	-20°C
3	Ergolid EKO -25°C	-25°C
4	Ergolid EKO -35°C	-35°C
5	Ergolid A -15°C	-15°C
6	Ergolid A -20°C	-20°C
7	Ergolid A -25°C	-25°C
8	Ergolid A -35°C	-35°C
9	Tyfocor LS	-20°C
10	ECO MPG-SOL 20	-20°C
11	ECO MPG-SOL 28	-28°C
12	ECO MPG-SOL 32	-32°C
13	Henock 35P35	-35°C

Flow P1 – flow calibration function required for correct heat output function. Rotometer or water meter must be installed in the sole work fluid circuit. When edition is open (value is blinking), the collector pump **P1** will be controlled for maximum capacity. Now, read flow value directly from a rotometer or measure (using water meter) how many liters of work fluid will flow for one minute and program the value to the controller. Correct flow value is needed to correctly count heat output by the controller.

Flow P2 –P2 pump calibration function for solar scheme **H**. To calibrate solar work fluid circulation speed, it is required to have rotometer or water meter installed. When edition is open (value is blinking), the collector pump **P2** will be controlled for maximum capacity. Correct flow value is needed to correctly count heat output by the controller. Flow calibration **P2** is available only in Solar thermal scheme **H**.



*For correct heat output counting in scheme **H**, calibration for both pumps is required.*

Vac. collector – vacuum collector function on/off. The function principle of operation is described in section 20.3.1.

Detect. level – setting that defines how much the collector temperature must rise (at started vacuum collector function) in one minute, to activate the collector pump.

Operation time – time to stop the collector pump, after the temperature set in Dect. level is reached.

20.3.1. Vacuum collector function

Settings needed for the vacuum collector function are described previous section.

The vacuum collector function (when enabled) checks the collector temperature and starts the collector pump, if after one minute the collector temperature will increase by level set in **Detection level**; the collector pump will be started for the time set for **Operation time**. After this short impulse, unless normal conditions for starting collector pump occur, the controller will continue checking the collector's temperature.

The vacuum collector function is disabled, if the collector temperature is below 0°C and there are alarm active that block the collector pump operation.

20.4. Manual mode

Manual mode allows manual controlling for outputs: **P1, P2, H**.

Outputs are controlled directly after the setting value edition is confirmed.

From this menu the controller will not return to main screen automatically.

After you leave manual mode, the controller returns to output controlling in accordance with operating algorithm.



In the manual mode all automatic actions are stopped. Leaving the controller in this mode for longer time may damage the system

20.5. Scheme wizard

Scheme wizard is to select type of installation. It is done by turning the knob to browse through schemes. Number and type of schemes depend on the controller version.

After selection, the controller will request to confirm the scheme.

21. FUSE REPLACEMENT



Cut off power supply to the controller before fuse replacement.

A 1.25A time-delay subminiature fuse with minimum interrupting current of 100A should be used, as per IEC 60127 standard. An example of a fuse meeting the requirements is **Schurter MXT-250 time-delay fuse**. To replace, open controller's enclosure and replace burnt fuse with a new one (Fig. 21.1).



The manufacturer reserves the right to make changes in design and software without prior notice.

Record of changes

3.X.1 z dn 9-06-2014 First edition

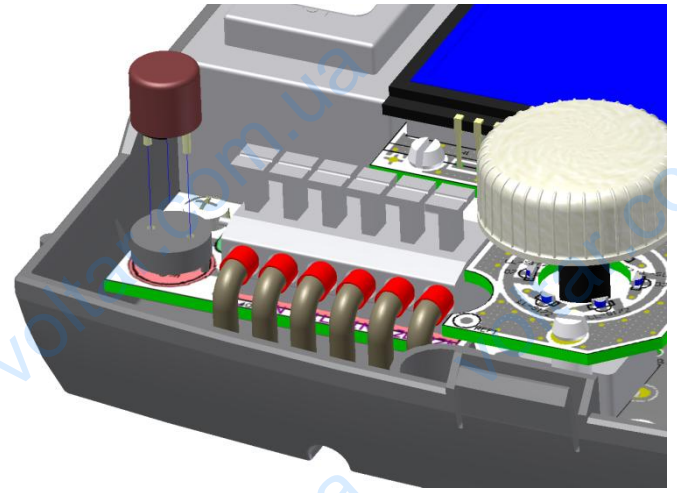

Fig. 21.1 Fuse replacement



SALUS Controls
ul. Bielska 4a, 43-200
Pszczyna, Poland