

APPLICAZIONI

Elettropompe sommersa in acciaio inox portatili a funzionamento automatico.

Impiegate per il prosciugamento acqua di infiltrazione, svuotamento di locali allagati o vasche, drenaggio acque di scarico pulite o leggermente sporche, irrigazioni di orti e giardini.

LIMITI D'IMPIEGO

- Temperatura liquido fino a 35°C (per un uso domestico secondo EN 60335-2-41)
- Temperatura max. liquido: 35°C (per altri impieghi)
- Massima profondità d'immersione 5 mt.
- Passaggio solidi Ø 8 mm
- Livello min. d'aspirazione 40 mm
- Servizio continuo

MOTORE

- Monofase 230V-50Hz automatico (con galleggiante)
- Trifase 230/400V-50Hz manuale
- Tenuta meccanica in bagno d'olio
- Condensatore permanente inserito
- Isolamento Classe F
- Protezione IP 68

MATERIALI

- | | |
|-------------------------------------|-----------------------------|
| - Maniglia | Acciaio Inox AISI 304+Nylon |
| - Cassa motore | Acciaio Inox AISI 304 |
| - Corpo pompa | Acciaio Inox AISI 304 |
| - Girante | Acciaio Inox AISI 304 |
| - Griglia aspirazione | Acciaio Inox AISI 304 |
| - Albero motore | Acciaio Inox AISI 304 |
| - Tenuta meccanica in camera d'olio | Silicio/Silicio/NBR |

OPERATING CONDITIONS

- Liquid temperature up to 35°C (for home use according to EN 60335-2-41)
- Temperature max. liquid: 35°C (for other uses)
- Maximum immersion depth 5 mt.
- Grain size inlet Ø 8 mm
- Min. suction level 40 mm
- Continuous duty

MOTOR

- Single-phase 230V-50Hz automatic (with floater)
- Three-phase 230/400V-50Hz manual
- Mechanical seal in oil bath
- Permanent split capacitor
- Insulation Class F
- Protection IP 68

MATERIALS

- | | |
|----------------------------------|--------------------------------|
| - Handle | Stainless Steel AISI 304+Nylon |
| - Motor casing | Stainless Steel AISI 304 |
| - Pump body | Stainless Steel AISI 304 |
| - Impeller | Stainless Steel AISI 304 |
| - Suction grid | Stainless Steel AISI 304 |
| - Shaft with rotor | Stainless Steel AISI 304 |
| - Mechanical seal in oil chamber | Silicon/Silicon/NBR |

APPLICATION

Hand-carry submersible automatic water pumps in stainless steel.

Able to drain infiltrating water, cellars or reservoirs, clean or slightly dirty water and for garden irrigation.



GIRANTE - IMPELLER

STAINLESS STEEL SUBMERSIBLE DRAINAGE PUMPS

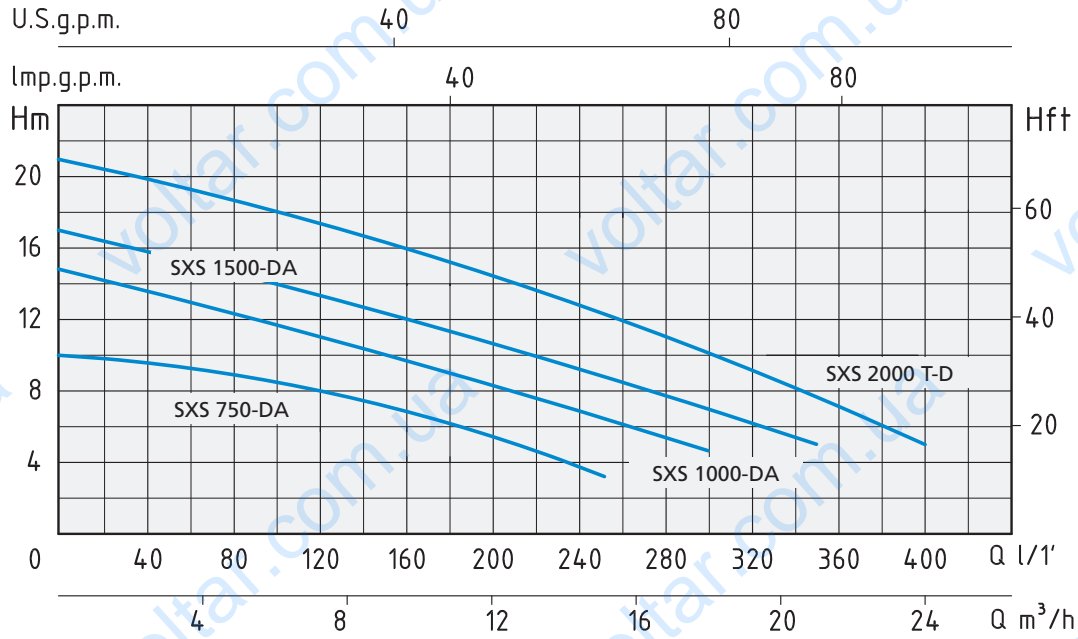

TIPO TYPE		POTENZA NOMINALE NOMINAL POWER		POTENZA ASSORBITA INPUT POWER	AMPERE		Q = PORTATA - CAPACITY																
Monofase Single-phase	Trifase Three-phase	P2		P1	Monofase Single-phase	Trifase Three-phase	Q = PORTATA - CAPACITY																
		HP	kW	kW			m³/h	0	3,6	5,4	7,2	9	12	15	18	21	24						
							lt/1'	0	60	90	120	150	200	250	300	350	400	Prevalenza manometrica totale in m.C.A. - Total head in meters w.c.					
							H (m)	10	9	8,5	8	7	5,5	3,5									
SXS 750-DA		0,75	0,55	0,8	3,5		15	13,5	12,8	12	11	9,5	8	5,5									
SXS 1000-DA		1	0,75	1,25	5,5		17	15,5	14,5	13,5	12,5	11	9	7	5								
SXS 1500-DA		1,5	1,1	1,5	6,5		21	19,5	18,5	17,5	16,5	14,5	12,5	10,5	7,5	4,5							
	SXS 2000 T-D	2	1,5	2		3,5																	

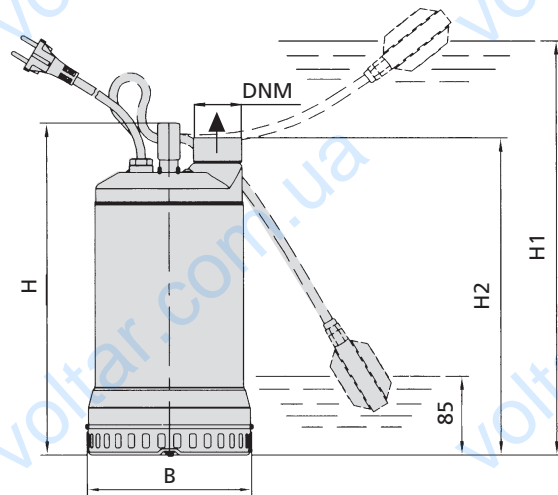
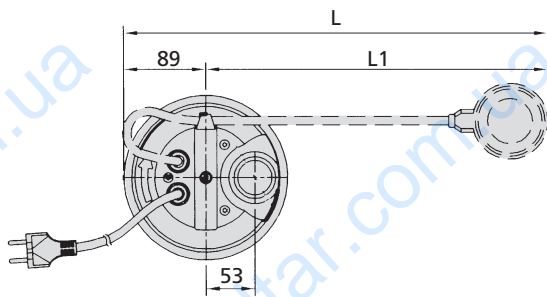

TIPO TYPE		DIMENSIONI mm - DIMENSIONS mm								DIMENSIONI DIMENSIONS mm			PESO WEIGHT
Monofase Single-phase	Trifase Three-phase	B	H	H1	H2	L	L1	DNM	CAVO CABLE	P	L	H	Kg
		SXS 750-DA		178	357	437	341	459	370	1" 1/2	10 mt H07RNF	208	
SXS 1000-DA		178	407	497	391	514	425	1" 1/2	10 mt H07RNF	208	264	454	14,3
SXS 1500-DA		178	407	497	391	514	425	1" 1/2	10 mt H07RNF	208	264	454	15,6
	SXS 2000 T-D	178	407	-	391	-	-	1" 1/2	10 mt H07RNF	208	264	454	16,1