

resideo Pressure Reducing Valve

Braukmann D06F

Pressure Reducing Valve
with balanced seat and set point scale

APPLICATION

According to EN 806-2 pressure reducing valves of this type protect household water installations against excessive pressure from the supply. They can also be used for industrial or commercial applications within the range of their specification.

By installing a pressure reducing valve, pressurisation damage is avoided and water consumption is reduced.

The set pressure is also maintained constant, even when there is wide inlet pressure fluctuation.

Reduction of the operating pressure and maintaining it at a constant level minimizes flow noise in the installation.

APPROVALS

- DVGW
- WRAS (up to 23 °C)

SPECIAL FEATURES

- Inlet pressure balancing – no influence on outlet pressure by fluctuating inlet pressure
- Up to size 1¹/₄" approved by LGA for low noise, Group 1 without limitations
- The valve insert is of high-quality synthetic material and can be fully exchanged
- The outlet pressure is set by turning the adjustment knob
- The set pressure is directly indicated on the set point scale
- The adjustment spring is not in contact with the drinking water
- Integral fine filter
- Also available without fittings
- Conforms to BSEN 1567
- All materials are UBA conform
- ACS certified



TECHNICAL DATA

Media	
Medium:	Drinking water
Connections/Sizes	
Connection sizes:	1/2" - 2"
Nominal sizes:	DN15 - DN50
Pressure values	
Max. inlet pressure with clear filter bowl:	16 bar
Max. inlet pressure with brass filter bowl:	25 bar
Outlet pressure:	1.5 - 6 bar
Preset outlet pressure:	3 bar
Min. pressure drop:	1 bar
Operating temperatures	
Max. operating temperature medium (10 bar/brass filter bowl):	70 °C
Max. operating temperature medium accord. to EN 1567:	30 °C

Note: Use the SM06T brass filter bowl, if the valve can be exposed to UV radiation or solvent vapors.

CONSTRUCTION

Overview	Components	Materials	
	1	Spring bonnet with adjustment knob and setting scale	High-quality synthetic material
	2	Housing with pressure gauge connections on both sides	Dezincification-resistant brass
	3	Threaded male connections (options A & B)	Brass
	4	Pressure gauge connection	-
	5	Filter bowl	Clear synthetic or brass
Not depicted components:			
	Adjustment spring	Spring steel	
	Valve insert complete with diaphragm and valve seat	High-quality synthetic material, EPDM diaphragm	
	Fine filter with 0.16 mm mesh	Stainless steel	
	Pressure gauge (see accessories)	High-quality synthetic material	
	Seals	EPDM	

METHOD OF OPERATION

Spring loaded pressure reducing valves operate by means of a force equalising system. The force of a diaphragm operates against the force of an adjustment spring. If the outlet pressure and therefore diaphragm force fall because water is drawn, the then greater force of the spring causes the valve to open. The outlet pressure then increases until the forces between the diaphragm and the spring are equal again.

The inlet pressure has no influence in either opening or closing of the valve. Because of this, inlet pressure fluctuation does not influence the outlet pressure, thus providing inlet pressure balancing.

TRANSPORTATION AND STORAGE

Keep parts in their original packaging and unpack them shortly before use.

The following parameters apply during transportation and storage:

Parameter	Value
Environment:	clean, dry and dust free
Min. ambient temperature:	5 °C
Max. ambient temperature:	55 °C
Min. ambient relative humidity:	25 % *
Max. ambient relative humidity:	85 % *

*non condensing

INSTALLATION GUIDELINES

Setup requirements

- Install in horizontal pipework with filter bowl downwards
- Install shut-off valves
- The device downstream should be protected by means of a safety valve (installed downstream of the pressure reducing valve). In these cases the delivery pressure of the pressure reducing valve shall be set to at least 20% below the response pressure of the pressure relief-valve according to EN 806-2
- The installation location should be protected against frost and be easily accessible
 - Pressure gauge can be read off easily
 - With clear filter bowl, degree of contamination can be easily seen
 - Simplified maintenance and cleaning
- Install downstream of the filter or strainer
- Provide a straight section of pipework of at least five times the nominal valve size after the pressure reducing valve (in accordance with EN 806-2)
- Requires regular maintenance in accordance with EN 806-5

Installation Example

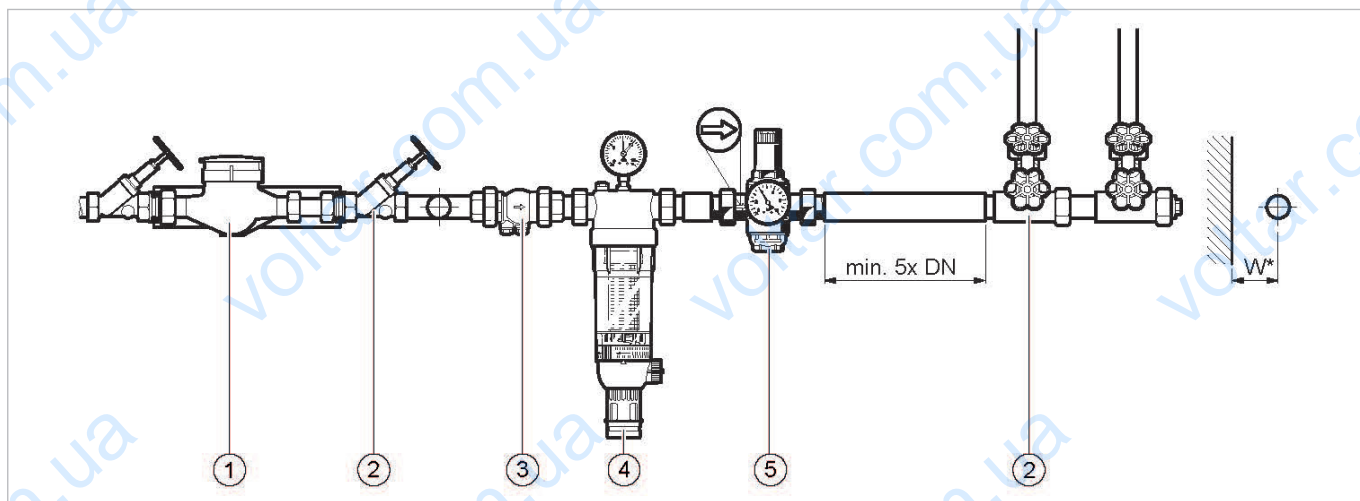

Fig. 1 Standard installation example for the pressure reducing valve

- 1 Water meter
- 2 Shut-off valve
- 3 Check valve
- 4 Filtering unit
- 5 Pressure reducing valve

Connection sizes:						
DN:	15	20	25	32	40	50
inch:	1/2"	3/4"	1"	1 1/4"	1 1/2"	2"
Distance in mm (W*):	55	60	60	60	70	70

* Required installation distances between the centerline of the pipework and the surrounding in dependency of the connection size.

TECHNICAL CHARACTERISTICS

kvs-Values

Connection sizes:	15	20	25	32	40	50
k _{VS} -value (m ³ /h):	2.4	3.1	5.8	5.9	12.6	12.0
IfBt designation:	P-IX 1582/I	P-IX 1582/I	P-IX 1582/I	P-IX 1582/I	- *	- *
DVGW registration number:	DW-6330 AT 2314					

* Compulsory testing in sizes R 1/2" to R 1 1/4"

Pressure drop characteristics

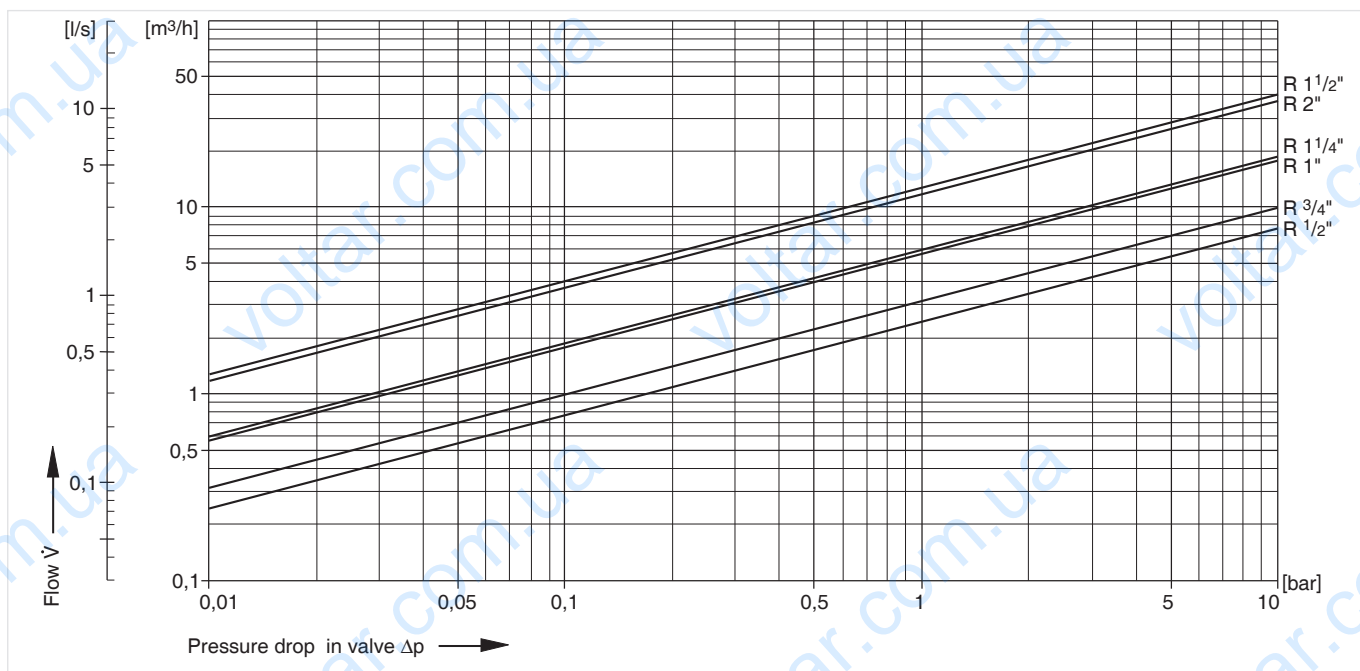
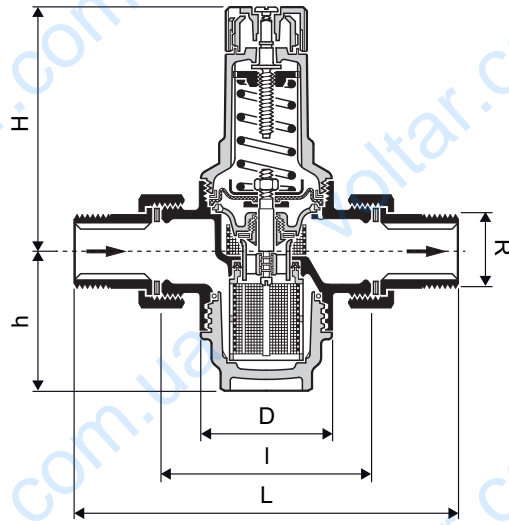

Fig. 2 Pressure drop within the valve in dependency of the flow rate and the used connection size

DIMENSIONS

Overview



Parameter	Values						
Connection sizes:	R	1/2"	3/4"	1"	1 1/4"	1 1/2"	2"
Nominal size diameter:	DN	15	20	25	32	40	50
Weight:	kg	0.8	1.0	1.4	2.0	3.3	4.5
Dimensions:	L	140	160	180	200	225	255
	I	80	90	100	105	130	140
	H	89	89	111	111	173	173
	h	58	58	64	64	126	126
	D	54	54	61	61	82	82

Note: All dimensions in mm unless stated otherwise.

ORDERING INFORMATION

The following tables contain all the information you need to make an order of an item of your choice. When ordering, please always state the type, the ordering or the part number.

Options

The valve is available in the following sizes: 1/2", 3/4", 1", 1 1/4", 1 1/2" and 2".

- standard
- not available

		D06F-...A	D06F-...B	D06F-...E
Max. operating temperature medium:	40 °C	•	-	•
	70 °C	-	•	-
Filter bowl:	clear	•	-	•
	brass	-	•	-
Connection type:	external threaded connection set on in- and outlet	•	•	-
	external thread on in- and outlet	-	-	•

Note: ... = space holder for connection size

Note: Ordering number example for 1 1/4" and type A valve: D06F-11/4A

Accessories

	Description	Dimension	Part No.
	M07M Pressure gauge Housing diameter 63 mm, rear connection thread G 1/4"		
		Range: 0 - 4 bar	M07M-A4
		Range: 0 - 10 bar	M07M-A10
		Range: 0 - 16 bar	M07M-A16
		Range: 0 - 25 bar	M07M-A25
	ZR06K Double ring wrench For removal of spring bonnet and filter bowl		ZR06K
	VST06A Connection set Threaded connections		
		1/2"	VST06-1/2A
		3/4"	VST06-3/4A
		1"	VST06-1A
		1 1/4"	VST06-1 1/4A
		1 1/2"	VST06-1 1/2A
2"	VST06-2A		
	VST06B Connection set Solder connections		
		1/2"	VST06-1/2B
		3/4"	VST06-3/4B
		1"	VST06-1B
		1 1/4"	VST06-1 1/4B
		1 1/2"	VST06-1 1/2B
2"	VST06-2B		

Spare Parts

Pressure Reducing Valve D06F, from 1997 onwards

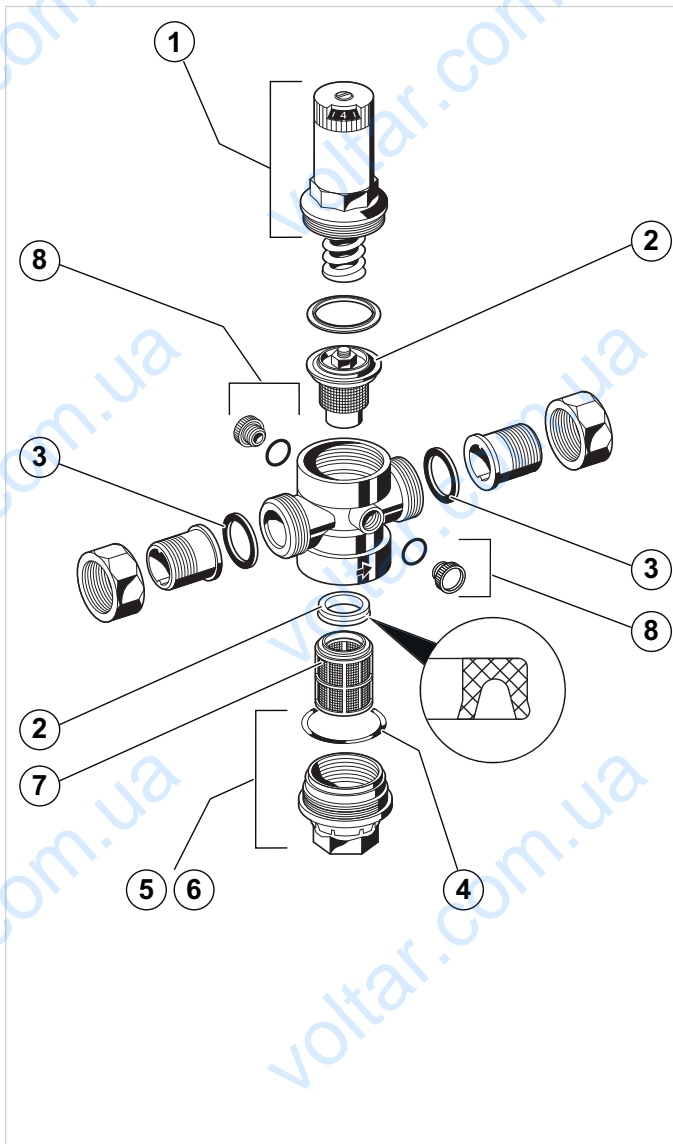
Overview

Description	Dimension	Part No.
1 Spring bonnet complete		
	1/2" - 1"	0901515
	1" + 1 1/4"	0901516
	1 1/2" + 2"	0901518
2 Valve insert complete (without filter)		
	1/2" + 3/4"	D06FA-1/2
	1" + 1 1/4"	D06FA-1B
	1 1/2" + 2"	D06FA-11/2
3 Union seal washer (10 pcs.)		
	1/2"	0901443
	3/4"	0901444
	1"	0901445
	1 1/4"	0901446
	1 1/2"	0901447
	2"	0901448
4 O-ring set (10 pcs.)		
	1/2" + 3/4"	0901246
	1" + 1 1/4"	0901499
	1 1/2" + 2"	0901248
5 Clear filter bowl with O-ring		
	1/2" + 3/4"	SK06T-1/2
	1" + 1 1/4"	SK06T-1B
	1 1/2" + 2"	SK06T-11/2
6 Brass filter bowl with O-ring		
	1/2" + 3/4"	SM06T-1/2
	1" + 1 1/4"	SM06T-1B
	1 1/2" + 2"	SM06T-11/2
7 Replacement filter insert		
	1/2" + 3/4"	ES06F-1/2A
	1" + 1 1/4"	ES06F-1B
	1 1/2" + 2"	ES06F-11/2A
8 Blanking plug with O-ring R¹/₄" (5 pcs.)		
	1/2" - 2"	S06K-1/4



Manufactured for
and on behalf of
Pittway Sàrl, Z.A., La Pièce 4,
1180 Rolle, Switzerland
by its authorised representative
Ademco 1 GmbH

For more information
homecomfort.resideo.com/europe

Ademco 1 GmbH, Hardhofweg 40,
74821 MOSBACH, GERMANY

Phone: +49 6261 810
Fax: +49 6261 81309